

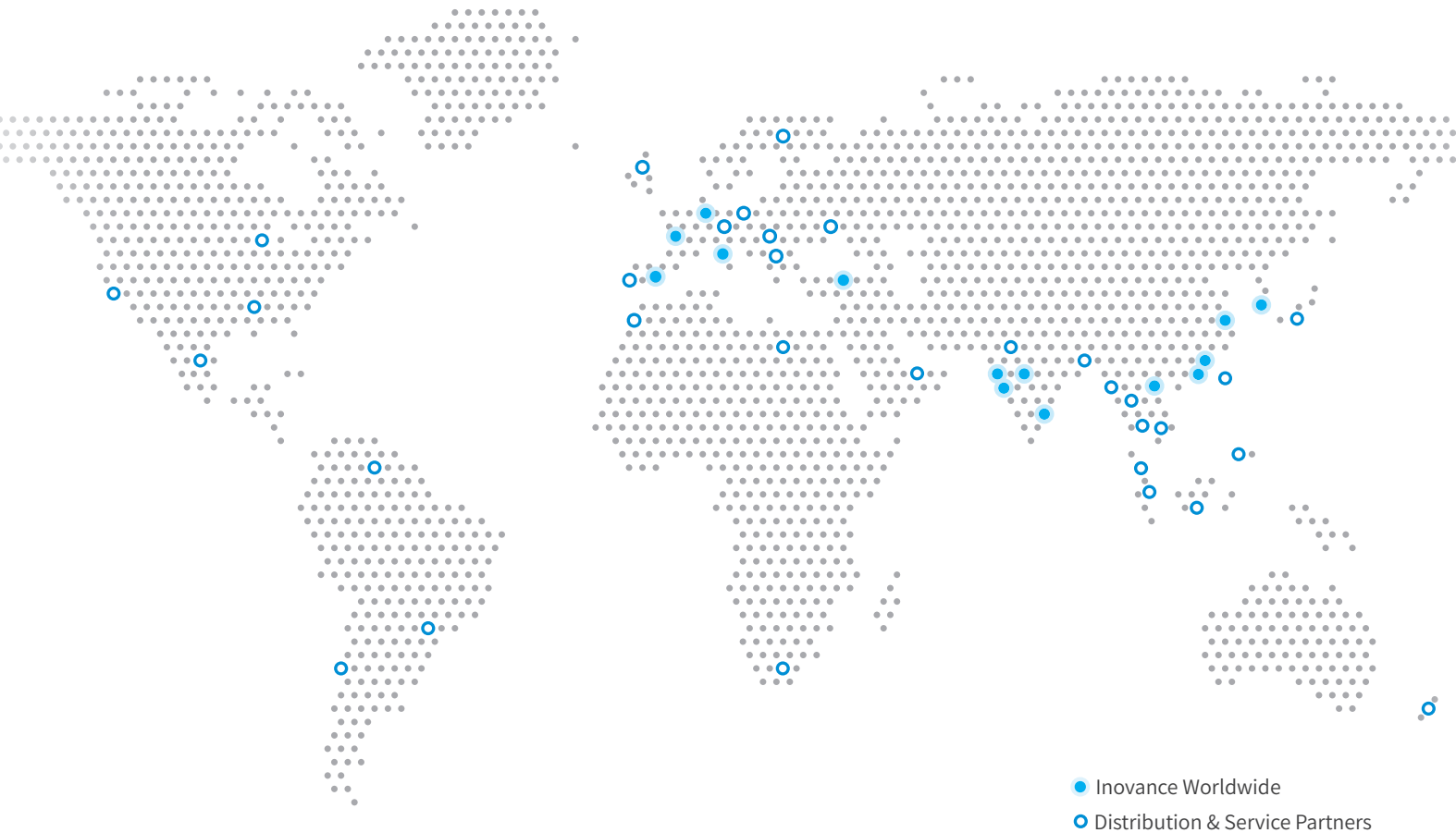

19120516A00

This brochure is subject to change without prior notice.
Copyright © Shenzhen Inovance Technology Co., Ltd.



- Inovance Worldwide
- Distribution & Service Partners

Advancing industrial technology, for a better world

Europe

- **Germany-Stuttgart**
☎ +49 (0) 7144 8990
✉ sales.de@inovance.eu
- **France-Bordeaux**
☎ +33 (0) 5594 01050
✉ sales.fr@inovance.eu
- **Spain-Barcelona**
☎ +34 93 504 94 48
✉ sales.es@inovance.eu
- **Italy-Milano**
☎ +39 (0) 2268 22318
✉ sales.it@inovance.eu

Turkey-Istanbul

- ☎ +90 (216) 706 17 89
- ✉ sales.tr@inovance.eu

Asia Pacific

India

- Chennai (Head Office) | ☎ +91 (0) 44 4380 0201
- Ahmedabad | ☎ +91 794003 4272
- Mumbai | ☎ +91 22 4971 5883
- New Delhi | ☎ +91 11 4165 4524
- Sales Network
Kolkata, Bengaluru, Pune, Coimbatore, Hyderabad, Vadodara, Jaipur

South Korea-Seoul

- ☎ +82 (0)2 3489 8850
- ✉ INOVANCEKR@inovance.eu

China

- Shenzhen Inovance Technology Co., Ltd.
- Suzhou Inovance Technology Co. Ltd.
- ☎ 4000-300124 (within China)
- ✉ info@inovance.com
- ✉ service@inovance.com
- Hong Kong SAR (International Export Office)
- ☎ +852 2751 6080
- ✉ info@inovance.eu
- **Vietnam - Hanoi**
☎ +84 948118793
✉ tiendinh@inovance.com

FOLLOW US



INOVANCE

MS1-R Series Servo Motor

High Performance Servo Motor

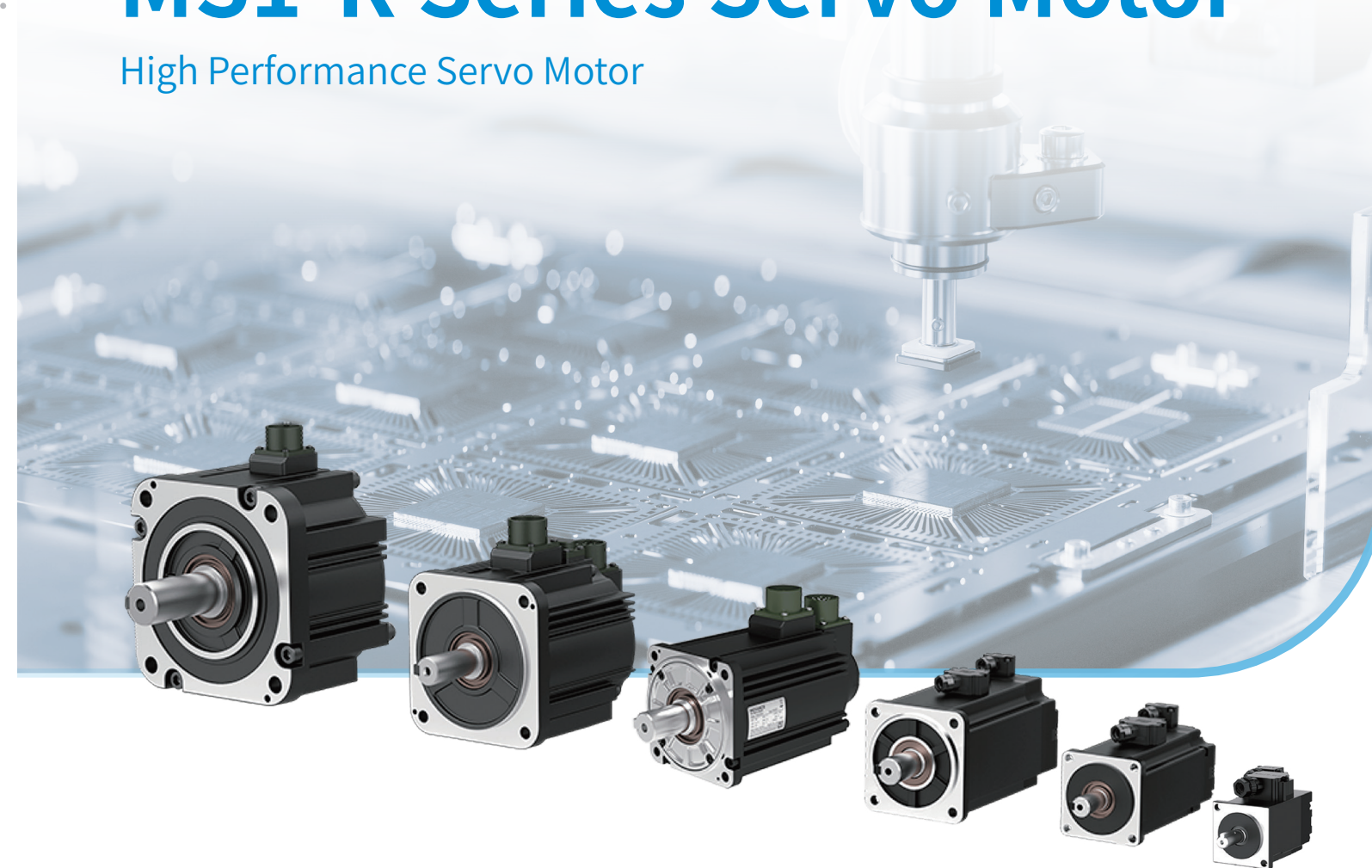

Features & functions

- Power from 0.05kW to 7.5kW with 6 types of frame size
 - Compact dimensions with more power per space
 - Optimized characteristics max.speed 7000rpm
 - Highest energy efficiency equivalent to IE5 level
 - Options: 23bit or 26bit multi-turn encoder
 - Perfect low torque, low speed ripple and high accuracy
- With or without brake





About Inovance

The Inovance Group, founded in 2003, is a rising star in the global industrial automation business and has revenues of \$4.2 in 2023. Inovance is headquartered in Shenzhen, China, and has built a global operation with offices and facilities in Germany, France, Italy, Spain, Turkey, India, and South Korea. Additionally, the company has a strong network of distribution partners around the world.

The company's flexible production techniques and expert understanding of all industry sectors - from plastics to printing to packaging to iron & steel production - have allowed it to establish globally leading industry-specific business units. Over the years, Inovance has built an engineering team with specialist expertise in industrial automation. This knowledge allows it to form strong partnerships with OEMs and end users, providing ongoing advice about how to get the most out of their automation solutions today, and how to stay prepared for the market and technology changes that are coming in future.

Forward, Always Progressing

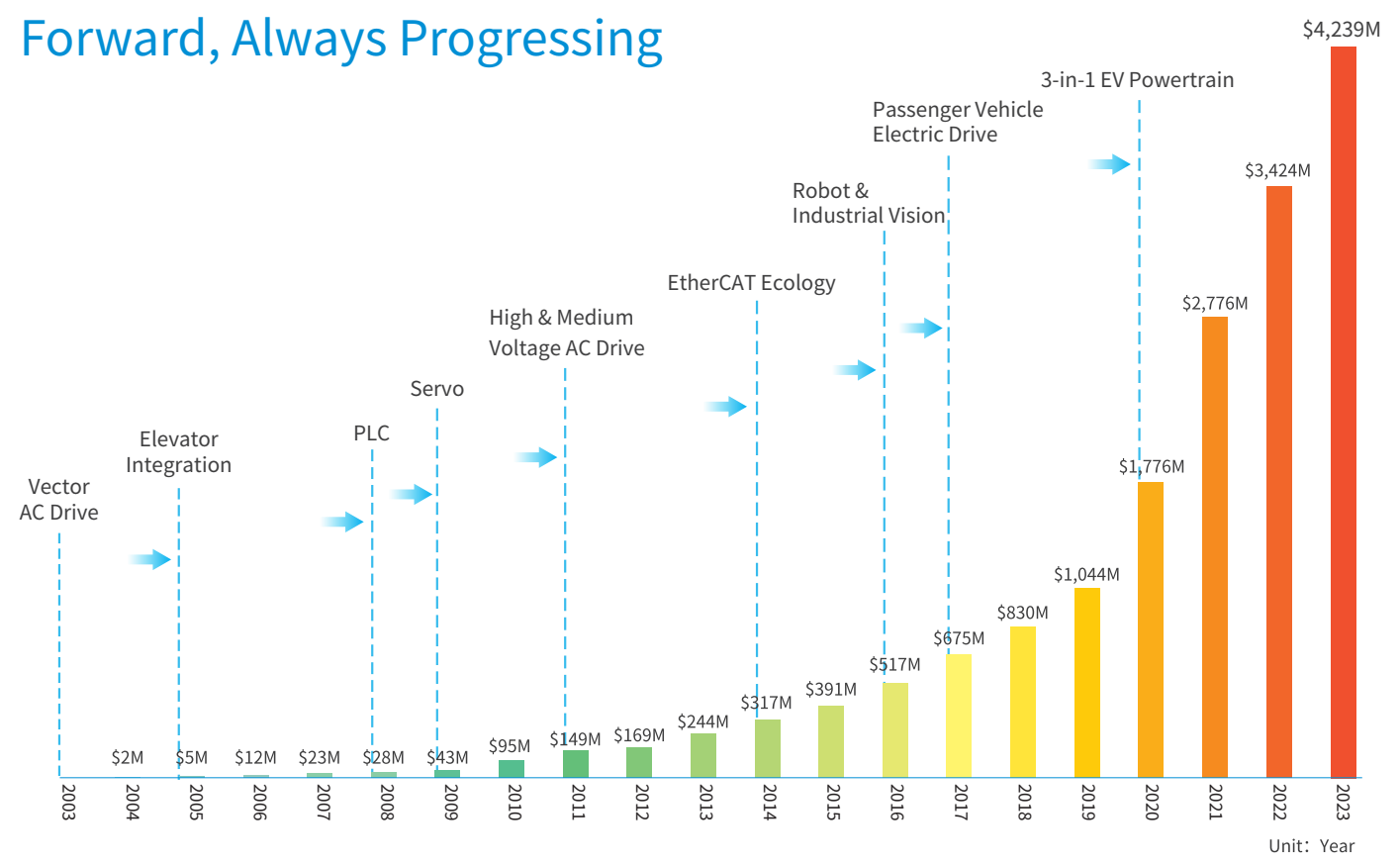

2003 founded	IPO:2010 Shenzhen, China	20,000 employees	Global network of offices and distributors	\$4.2+bn revenues in 2023

 Servo System 4,500,000+ sets delivered in 2023	 AC Drive 2,20,000+ sets delivered in 2023	 Industrial Robot 22,000+ sets delivered in 2023	 Controller 3,400,000+ sets delivered in 2023
--	---	---	--

6 Highlights

Advanced technical design

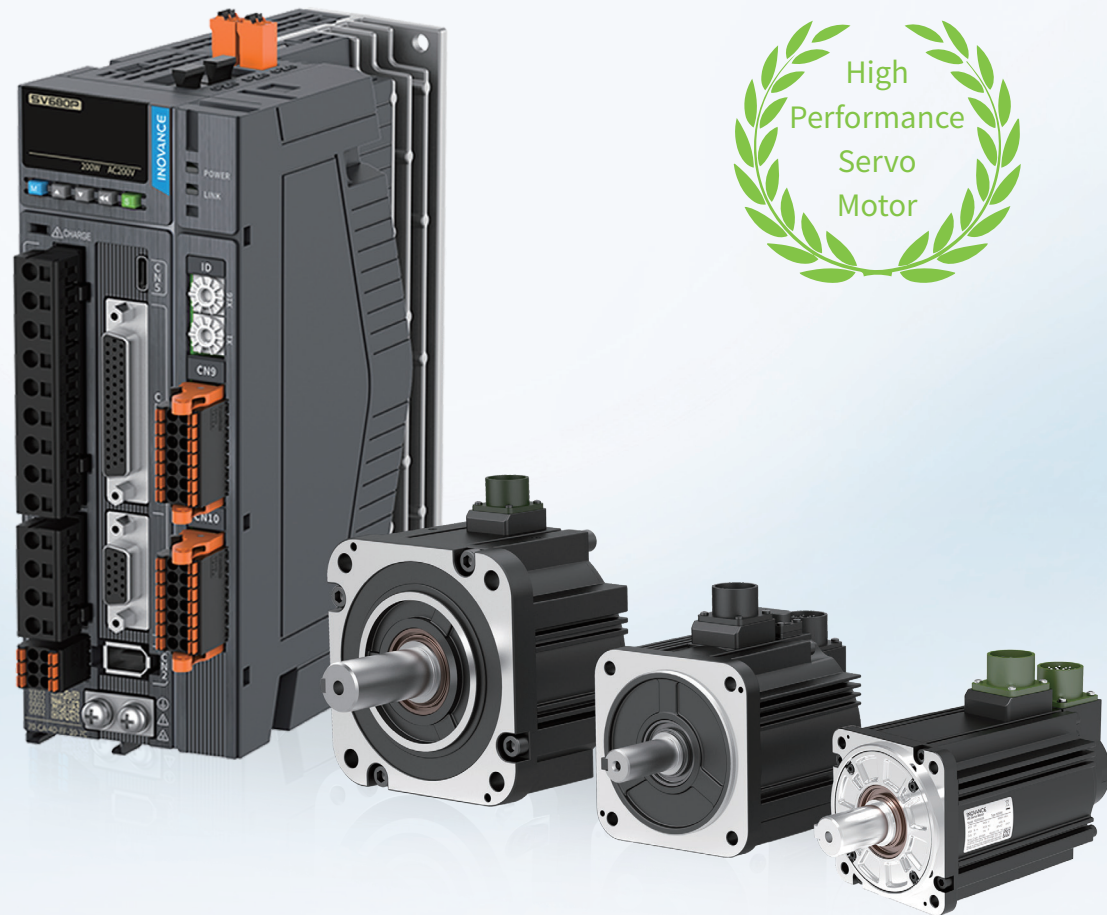

Small size

Smaller footprint with torque output unchanged, max. reduction of length reaching **29%**

Dimensions of mounting interfaces **Compatible** with MS1-Z series motors

Low temperature rise

Optimized electromagnetic circuit to reduce temperature rise
Flange size 60 & 80: Temperature rise reduced by **20K** compared with previous motors

Full range of motors

Ultra-low inertia available for motors with flange size 60/80 to better fit applications requiring quick jog control;
220 V models available for motors with flange size 100/130/180;
Regular **26-bit multi-turn absolute encoder** and **functional safety-type** 26-bit multi-turn absolute encoder available for applications requiring high precision

High stiffness

Stiffness of typical models **increased by five levels**

High energy-saving performance

550 W to 7.5 kW motors compliant with energy efficiency equal to **IE5 standard**

High speed

Max. speed of MS1H1 and MS1H4 motors with flange size 40/60/80 increased from 6000 rpm to **7000 rpm**
Max. speed of MS1H2 motors increased from 5000 rpm to **6000 rpm**
Max. speed of MS1H3 motors (flange size 130/180) increased from 3000 rpm to **4500 rpm**
Note: The preceding speeds are for motors with 23-bit or 26-bit encoders.

MS1-R Naming Rules

MS1 H1- 75B 30C B - A3 3 1 R - * - INT

① ② ③ ④ ⑤ ⑥ ⑦ ⑧ ⑨ ⑩ ⑪

① MS1 series servo motor	④ Rated speed (rpm) Comprised of a letter and two digits B: x 10 C: x 100 Example: 30C: 3000 rpm	⑦ Shaft connection mode 3: Solid and keyed, with threaded hole in the shaft center
② Inertia and capacity type H1: Low inertia, small capacity H2: Low inertia, medium capacity H3: Medium inertia, medium capacity H4: Medium inertia, small capacity	⑤ Voltage calss (V) B: 220 D: 380	⑧ Brake, reducer, oil seal ^[1] 0: Without oil seal or brake 1: With oil seal, without brake 2: Without oil seal, with brake 4: With oil seal and brake
③ Rated power (W) Comprised of a letter and two digits B: x 10 C: x 100 Example: 75B: 750 W	⑥ Encoder type Comprised of a letter and a digit A6: 26-bit multi-turn absolute encoder S6: Functional safety-type 26-bit multi-turn absolute encoder A3: 23-bit multi-turn absolute encoder	⑨ Sub-series No. R: R series
		⑩ Customization information _: Standard type -S: Flying leads type -**: Other customized types
		⑪ Model type INT: International

[1]: Flange size 40mm with H1 type motors are not equipped with an oil seal.

Technical Data

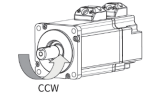
Item	Description
Duty type	S1 (Continuous duty)
Vibration class	V15 ^[1]
Insulation resistance	500 VDC, above 10 MΩ
Ambient temperature	0°C to 40°C (non-frozen) (See the derating curve for temperatures above 40°C.)
Ambient humidity	20% to 80% (without condensation)
Storage environment	Observe the following environment requirements for storing a de-energized motor: · Storage temperature: -20° C to +60° C (non-frozen) · Storage humidity: 20% to 80% RH (without condensation)
Excitation mode	Permanent magnet
Installation mode	Flange type
Insulation class	F (155°C)
Insulation voltage	1 min for 1500 VAC (220 V class); 1 min for 1800 VAC (380 V class)
IP rating of enclosure	IP67 (excluding shaft opening and connectors of flying lead type motors)
Ambient humidity	20% to 80%RH (without condensation)
Direction of rotation	Rotating counterclockwise when viewed from the shaft extension side with forward run commands 
Vibration resistance ^{[2][4]}	49 m/s ² (Flange face as standard)
Shock resistance ^{[3][4]}	490 m/s ² (Flange face as standard); Number of shocks: Two
Altitude	Derating is required only for altitudes above 1000 m.
Certification	CE/UKCA/UL/EAC/ROHS

Note: [1] Vibration level V15 represents the vibration amplitude of the servo motor is lower than 15 μm during operation at rated speed.

[2] The vertical, side-to-side, and front-to-back vibration resistance in three directions when the motor is mounted with the shaft in a horizontal position is given in the above table.

[3] The shock resistance for shock in the vertical direction when the motor is mounted with the shaft in a horizontal position is given in the above table.

[4] Do not operate the system at a fixed frequency because exceeding the allowable vibration value can damage the system.

Technical Data of MS1-R Motors with 26-bit Encoder

MS1H1 motors with low inertia and small capacity (flange size 40/60/80)

Motor Model MS1H1-	05B30CB	10B30CB	20B30CB	40B30CB	55B30CB	75B30CB	10C30CB
Flange size (mm)	40	40	60	60	80	80	80
Rated power (kW)	0.05	0.1	0.2	0.4	0.55	0.75	1.0
Rated voltage (V)	220	220	220	220	220	220	220
Rated torque (N·m)	0.16	0.32	0.64	1.27	1.75	2.39	3.18
Max. torque (N·m)	0.56	1.12	2.24	4.45	6.13	8.36	11.13
Rated current (A)	1.2	1.2	1.5	2.5	3.9	4.4	6.2
Max. current (A)	4.8	4.8	5.3	9.8	15	16.9	24
Rated speed n_n (rpm)	3000	3000	3000	3000	3000	3000	3000
Max. speed n_{max} (rpm)	7000	7000	7000	7000	7000	7000	7000
Torque coefficient (N·m/A)	0.15	0.30	0.51	0.57	0.51	0.62	0.59
Rotor moment of inertia (kg·cm ²)	0.018 (0.0208)	0.0316 (0.0345)	0.094 (0.106)	0.145 (0.157)	0.55 (/)	0.68 (0.71)	0.82 (0.87)
Applicable drive (SV680)	S1R6	S1R6	S1R6	S2R8	S5R5	S5R5	S7R6

MS1H2 motors with low inertia and medium capacity (flange size 100)

Motor Model MS1H2-	10C30CB	10C30CD	15C30CB	15C30CD	20C30CB	20C30CD	25C30CB	25C30CD
Flange size (mm)	100	100	100	100	100	100	100	100
Rated power (kW)	1.0	1.0	1.5	1.5	2.0	2.0	2.5	2.5
Rated voltage (V)	220	380	220	380	220	380	220	380
Rated torque (N·m)	3.18	3.18	4.9	4.9	6.36	6.36	7.96	7.96
Max. torque (N·m)	9.54	9.54	14.7	14.7	19.1	19.1	23.9	23.9
Rated current (A)	6.4	3.3	8.6	4.2	11.3	5.6	14.7	7.2
Max. current (A)	23	11	32	14	42	20	53	26
Rated speed n_n (rpm)	3000	3000	3000	3000	3000	3000	3000	3000
Max. speed n_{max} (rpm)	6000	6000	6000	6000	6000	6000	6000	6000
Torque coefficient (N·m/A)	0.54	1.07	0.62	1.28	0.60	1.19	0.60	1.18
Rotor moment of inertia (kg·cm ²)	1.78 (2.6)	1.78 (2.6)	2.35 (3.17)	2.35 (3.17)	2.92 (3.74)	2.92 (3.74)	3.49 (4.3)	3.49 (4.3)
Applicable drive (SV680)	S7R6	T3R5	S012	T5R4	S018	T8R4	S022	T012

MS1H2 motors with low inertia and medium capacity (flange size 130)

Motor Model MS1H2-	30C30CB	30C30CD	40C30CB	40C30CD	50C30CB	50C30CD
Flange size (mm)	130	130	130	130	130	130
Rated power (kW)	3.0	3.0	4.0	4.0	5.0	5.0
Rated voltage (V)	220	380	220	380	220	380
Rated torque (N·m)	9.8	9.8	12.6	12.6	15.8	15.8
Max. torque (N·m)	24.5	29.4	31.5	37.8	39.5	47.4
Rated current (A)	16.6	8.9	22	13.5	22	17
Max. current (A)	55	29	67.5	42.5	67.5	52.5
Rated speed n_n (rpm)	3000	3000	3000	3000	3000	3000
Max. speed n_{max} (rpm)	6000	6000	6000	6000	6000	6000
Torque coefficient (N·m/A)	0.67	1.25	0.65	1.06	0.81	1.04
Rotor moment of inertia (kg·cm ²)	6.4 (9.38) ^[1]	6.4 (9.38)	9 (11.98)	9 (11.98)	11.6 (14.58)	11.6 (14.58)
Applicable drive (SV680) ^[2]	S022	T012	S027	T017	S027	T021

Note:[1] Values in the parentheses are rotor moment of inertia values for motors with brake.

[2] The motor with 26-bit encoder matches SV680 series servo drives. Drive model description: S-220 V voltage class; T-380 V voltage class; 1R6-Rated output current 1.6 A...; 027-Rated output current 27 A

MS1H3 motors with medium inertia and medium capacity (flange size 130)

Motor Model MS1H3-	85B15CB	85B15CD	13C15CB	13C15CD	18C15CB	18C15CD
Flange size (mm)	130	130	130	130	130	130
Rated power (kW)	0.85	0.85	1.3	1.3	1.8	1.8
Rated voltage (V)	220	380	220	380	220	380
Rated torque (N·m)	5.39	5.39	8.34	8.34	11.5	11.5
Max. torque (N·m)	13.5	13.5	20.85	20.85	28.75	28.75
Rated current (A)	6.6	3.5	10.5	5.1	11.9	6.75
Max. current (A)	17.2	8.5	27.3	12.6	32.2	17.7
Rated speed n_n (rpm)	1500	1500	1500	1500	1500	1500
Max. speed n_{max} (rpm)	4500	4500	4500	4500	4500	4500
Torque coefficient (N·m/A)	0.93	1.84	0.89	1.85	1.05	1.87
Rotor moment of inertia (kg·cm ²)	13.56 (15.8)	13.56 (15.8)	19.25 (21.5)	19.25 (21.5)	24.9 (27.2)	24.9 (27.2)
Applicable drive (SV680)	S7R6	T3R5	S012	T5R4	S018	T8R4

MS1H3 motors with medium inertia and medium capacity (flange size 180)

Motor Model MS1H3-	29C15CB	29C15CD	44C15CB	44C15CD	55C15CD	75C15CD
Flange size (mm)	180	180	180	180	180	180
Rated power (kW)	2.9	2.9	4.4	4.4	5.5	7.5
Rated voltage (V)	220	380	220	380	380	380
Rated torque (N·m)	18.6	18.6	28.4	28.4	35	48
Max. torque (N·m)	46.5	46.5	71.1	71.1	87.6	119
Rated current (A)	18	10.5	25.5	16	20.7	25
Max. current (A)	52.5	29.75	67	42	52	65
Rated speed n_n (rpm)	1500	1500	1500	1500	1500	1500
Max. speed n_{max} (rpm)	4500	4500	4500	4500	4500	4500
Torque coefficient (N·m/A)	1.16	1.94	1.25	1.96	1.92	2.13
Rotor moment of inertia (kg·cm ²)	44.7 (52.35)	44.7 (52.35)	64.9 (72.55)	64.9 (72.55)	86.9 (94.55)	127.5 (135.15)
Applicable drive (SV680)	S022	T012	S027	T017	T021	T026

MS1H4 motors with medium inertia and small capacity (flange size 40/60/80)

Motor Model MS1H4-	05B30CB	10B30CB	20B30CB	40B30CB	55B30CB	75B30CB	10C30CB
Flange size (mm)	40	40	60	60	80	80	80
Rated power (kW)	0.05	0.1	0.2	0.4	0.55	0.75	1.0
Rated voltage (V)	220	220	220	220	220	220	220
Rated torque (N·m)	0.16	0.32	0.64	1.27	1.75	2.39	3.18
Max. torque (N·m)	0.56	1.12	2.24	4.45	6.13	8.37	11.13
Rated current (A)	1.27	1.27	1.3	2.4	3.3	4.4	6.5
Max. current (A)	4.78	4.78	5.3	9.2	13.2	16.9	24
Rated speed n_n (rpm)	3000	3000	3000	3000	3000	3000	3000
Max. speed n_{max} (rpm)	7000	7000	7000	7000	7000	7000	7000
Torque coefficient (N·m/A)	0.15	0.29	0.55	0.58	0.58	0.63	0.53
Rotor moment of inertia (kg·cm ²)	0.038 (0.04)	0.072 (0.074)	0.22 (0.23)	0.43 (0.44)	1.12 (/)	1.46 (1.51)	1.87 (1.97)
Applicable drive (SV680)	S1R6	S1R6	S1R6	S2R8	S5R5	S5R5	S7R6

Technical Data of MS1-R Motors with 23-bit encoder

MS1H1 motors with low inertia and small capacity (flange size 40/60/80)

Motor Model MS1H1-	05B30CB	10B30CB	20B30CB	40B30CB	55B30CB	75B30CB	10C30CB
Flange size (mm)	40	40	60	60	80	80	80
Rated power (kW)	0.05	0.1	0.2	0.4	0.55	0.75	1.0
Rated voltage (V)	220	220	220	220	220	220	220
Rated torque (N·m)	0.16	0.32	0.64	1.27	1.75	2.39	3.18
Max. torque (N·m)	0.56	1.12	2.24	4.45	6.13	8.36	11.13
Rated current (A)	1.2	1.2	1.5	2.5	3.9	4.4	6.2
Max. current (A)	4.8	4.8	5.3	9.8	15	16.9	24
Rated speed n_n (rpm)	3000	3000	3000	3000	3000	3000	3000
Max. speed n_{max} (rpm)	7000	7000	7000	7000	7000	7000	7000
Torque coefficient (N·m/A)	0.15	0.30	0.51	0.57	0.51	0.62	0.59
Rotor moment of inertia (kg·cm ²)	0.018 (0.0208)	0.0316 (0.0345)	0.094 (0.106)	0.145 (0.157)	0.55 (/)	0.68 (0.71)	0.82 (0.87)
Applicable drive (SV670) ^[2]	S1R6	S1R6	S1R6	S2R8	S5R5	S5R5	S7R6
Applicable drive (SV660)	S1R6	S1R6	S1R6	S2R8	S5R5	S5R5	S7R6

MS1H2 motors with low inertia and medium capacity (flange size 100)

Motor Model MS1H2-	10C30CB	10C30CD	15C30CB	15C30CD	20C30CB	20C30CD	25C30CB	25C30CD
Flange size (mm)	100	100	100	100	100	100	100	100
Rated power (kW)	1.0	1.0	1.5	1.5	2.0	2.0	2.5	2.5
Rated voltage (V)	220	380	220	380	220	380	220	380
Rated torque (N·m)	3.18	3.18	4.9	4.9	6.36	6.36	7.96	7.96
Max. torque (N·m)	9.54	9.54	14.7	14.7	19.1	19.1	23.9	23.9
Rated current (A)	6.4	3.3	8.6	4.2	11.3	5.6	14.7	7.2
Max. current (A)	23	11	32	14	42	20	53	26
Rated speed n_n (rpm)	3000	3000	3000	3000	3000	3000	3000	3000
Max. speed n_{max} (rpm)	6000	6000	6000	6000	6000	6000	6000	6000
Torque coefficient (N·m/A)	0.54	1.07	0.62	1.28	0.60	1.19	0.60	1.18
Rotor moment of inertia (kg·cm ²)	1.78 (2.6)	1.78 (2.6)	2.35 (3.17)	2.35 (3.17)	2.92 (3.74)	2.92 (3.74)	3.49 (4.3)	3.49 (4.3)
Applicable drive (SV670)	S7R6	T3R5	S012	T5R4	S018 ^[4]	T8R4	S022	T012 ^[5]
Applicable drive (SV660)	S7R6	T3R5	S012	T5R4	S012	T8R4	/	T012

MS1H2 motors with low inertia and medium capacity (flange size 130)

Motor Model MS1H2-	30C30CB	30C30CD	40C30CB	40C30CD	50C30CB	50C30CD
Flange size (mm)	130	130	130	130	130	130
Rated power (kW)	3.0	3.0	4.0	4.0	5.0	5.0
Rated voltage (V)	220	380	220	380	220	380
Rated torque (N·m)	9.8	9.8	12.6	12.6	15.8	15.8
Max. torque (N·m)	24.5	29.4	31.5	37.8	39.5	47.4
Rated current (A)	16.6	8.9	22	13.5	22	17
Max. current (A)	55	29	67.5	42.5	67.5	52.5
Rated speed n_n (rpm)	3000	3000	3000	3000	3000	3000
Max. speed n_{max} (rpm)	6000	6000	6000	6000	6000	6000
Torque coefficient (N·m/A)	0.67	1.25	0.65	1.06	0.81	1.04
Rotor moment of inertia (kg·cm ²)	6.4 (9.38)	6.4 (9.38)	9 (11.98)	9 (11.98)	11.6 (14.58)	11.6 (14.58)
Applicable drive (SV670)	S022	T012	S027	T017	S027	T021 ^[6]
Applicable drive (SV660)	/	T012	/	T017	/	T021

Note: [1] Values in the parentheses are rotor moment of inertia values for motors with brake. The slash symbol "/" represents this drive model is not available.

[2] The motor with 18-bit encoder matches SV630 series servo drives. Drive model description: S-220 V voltage class; T-380 V voltage class; 1R6-Rated output current 1.6 A...; 027-Rated output current 27 A

MS1H3 motors with medium inertia and medium capacity (flange size 130)

Motor Model MS1H3-	85B15CB	85B15CD	13C15CB	13C15CD	18C15CB	18C15CD
Flange size (mm)	130	130	130	130	130	130
Rated power (kW)	0.85	0.85	1.3	1.3	1.8	1.8
Rated voltage (V)	220	380	220	380	220	380
Rated torque (N·m)	5.39	5.39	8.34	8.34	11.5	11.5
Max. torque (N·m)	13.5	13.5	20.85	20.85	28.75	28.75
Rated current (A)	6.6	3.5	10.5	5.1	11.9	6.75
Max. current (A)	17.2	8.5	27.3	12.6	32.2	17.7
Rated speed n_n (rpm)	1500	1500	1500	1500	1500	1500
Max. speed n_{max} (rpm)	4500	4500	4500	4500	4500	4500
Torque coefficient (N·m/A)	0.93	1.84	0.89	1.85	1.05	1.87
Rotor moment of inertia (kg·cm ²)	13.56 (15.8)	13.56 (15.8)	19.25 (21.5)	19.25 (21.5)	24.9 (27.2)	24.9 (27.2)
Applicable drive (SV670)	S7R6	T3R5	S012	T5R4	S012	T8R4
Applicable drive (SV660)	S7R6	T3R5	S012	T5R4	S012 ^[4]	T8R4

MS1H3 motors with medium inertia and medium capacity (flange size 180)

Motor Model MS1H3-	29C15CB	29C15CD	44C15CB	44C15CD	55C15CD	75C15CD
Flange size (mm)	180	180	180	180	180	180
Rated power (kW)	2.9	2.9	4.4	4.4	5.5	7.5
Rated voltage (V)	220	380	220	380	380	380
Rated torque (N·m)	18.6	18.6	28.4	28.4	35	48
Max. torque (N·m)	46.5	46.5	71.1	71.1	87.6	119
Rated current (A)	18	10.5	25.5	16	20.7	25
Max. current (A)	52.5	29.75	67	42	52	65
Rated speed n_n (rpm)	1500	1500	1500	1500	1500	1500
Max. speed n_{max} (rpm)	4500	4500	4500	4500	4500	4500
Torque coefficient (N·m/A)	1.16	1.94	1.25	1.96	1.92	2.13
Rotor moment of inertia (kg·cm ²)	44.7 (52.35)	44.7 (52.35)	64.9 (72.55)	64.9 (72.55)	86.9 (94.55)	127.5 (135.15)
Applicable drive (SV670)	S022	T012	S027	T017	T021	T026
Applicable drive (SV660)	/	T012	/	T017	T021	T026

MS1H4 motors with medium inertia and small capacity (flange size 40/60/80)

Motor Model MS1H4-	05B30CB	10B30CB	20B30CB	40B30CB	55B30CB	75B30CB	10C30CB
Flange size (mm)	40	40	60	60	80	80	80
Rated power (kW)	0.05	0.1	0.2	0.4	0.55	0.75	1.0
Rated voltage (V)	220	220	220	220	220	220	220
Rated torque (N·m)	0.16	0.32	0.64	1.27	1.75	2.39	3.18
Max. torque (N·m)	0.56	1.12	2.24	4.45	6.13	8.37	11.13
Rated current (A)	1.27	1.27	1.3	2.4	3.3	4.4	6.5
Max. current (A)	4.78	4.78	5.3	9.2	13.2	16.9	24
Rated speed n_n (rpm)	3000	3000	3000	3000	3000	3000	3000
Max. speed n_{max} (rpm)	7000	7000	7000	7000	7000	7000	7000
Torque coefficient (N·m/A)	0.15	0.29	0.55	0.58	0.58	0.63	0.53
Rotor moment of inertia (kg·cm ²)	0.038 (0.04)	0.072 (0.074)	0.22 (0.23)	0.43 (0.44)	1.12 (/)	1.46 (1.51)	1.87 (1.97)
Applicable drive (SV670)	S1R6	S1R6	S1R6	S2R8	S5R5	S5R5	S7R6
Applicable drive (SV660)	S1R6	S1R6	S1R6	S2R8	S5R5	S5R5	S7R6

Note: [3] MS1-R series H4 models can be used to replace MS1-Z series H1/H4 motor models.

[4] For motors matching IS620 and IS650 series servo drives, see the related selection guide of the drive.

Motor type: 18C15CB, 20C30CB, 25C30CD, 50C30CD matching with different power of drive, the motor max. torque value is different, please refer the T-N curve to select.

Torque-Speed Characteristics of MS1-R Motors with 26-bit Encoders

MS1H1
low
inertia,
small
capacity

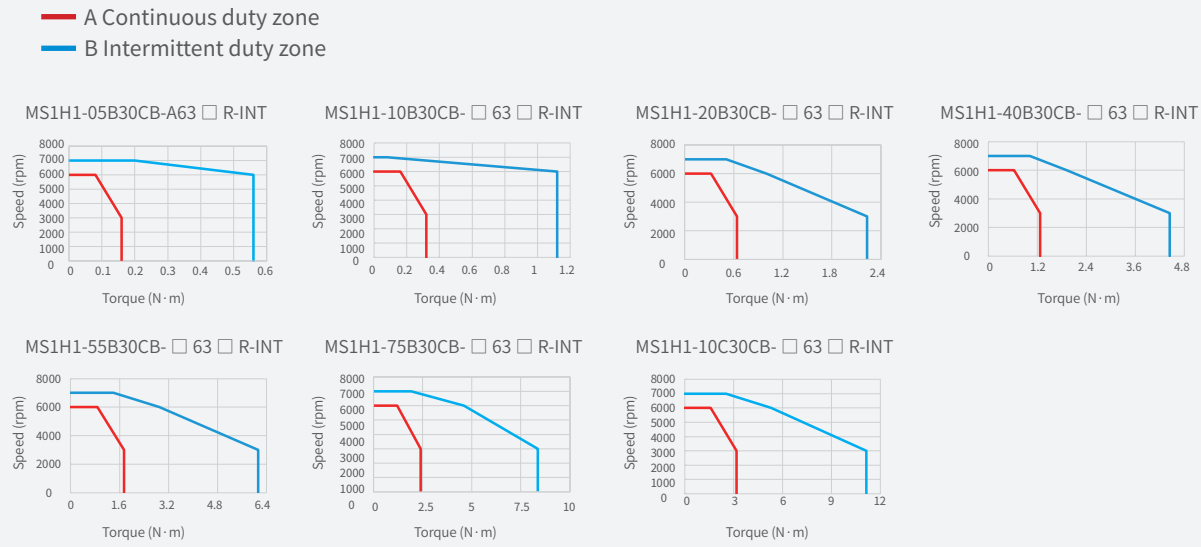

MS1H2
low
inertia,
small
capacity

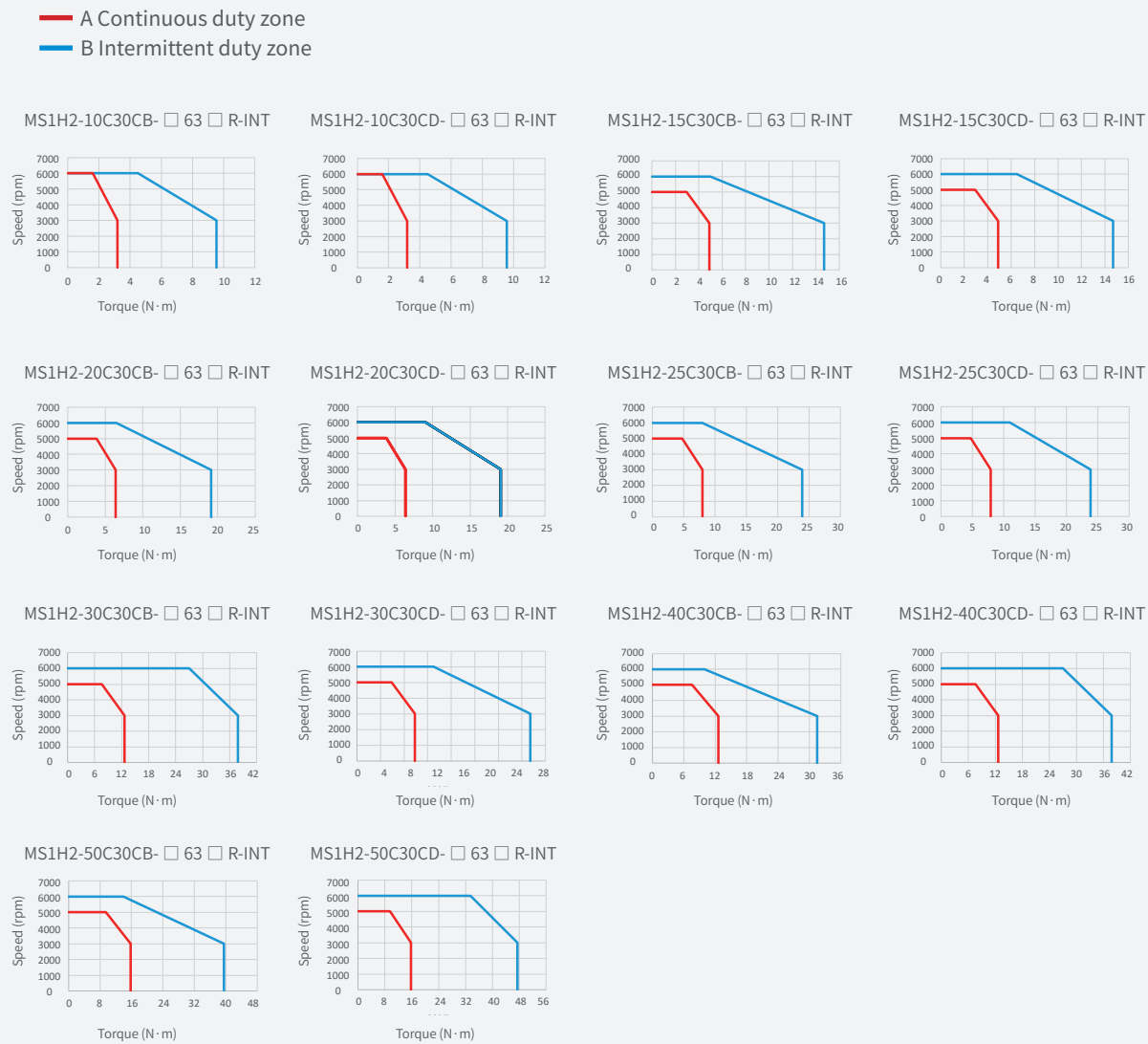

MS1H3
medium
inertia,
medium
capacity

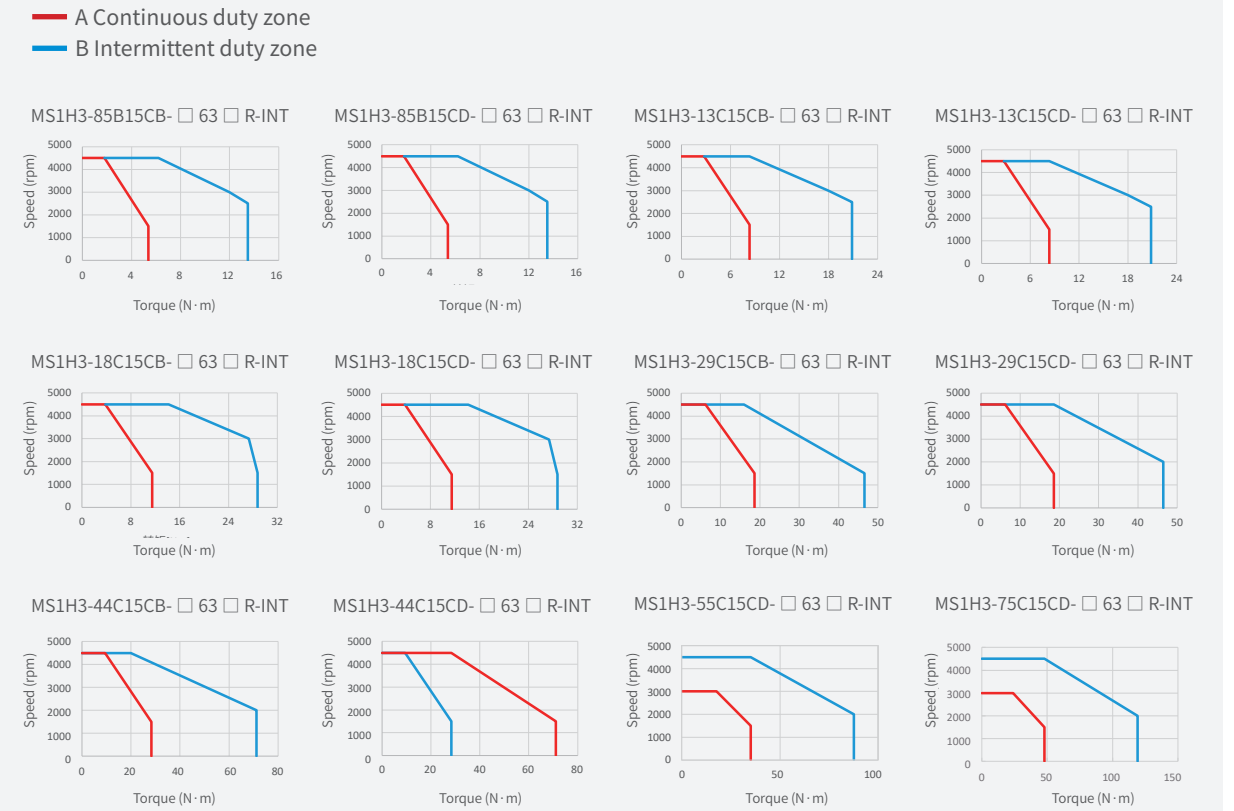

MS1H4
medium
inertia,
small
capacity

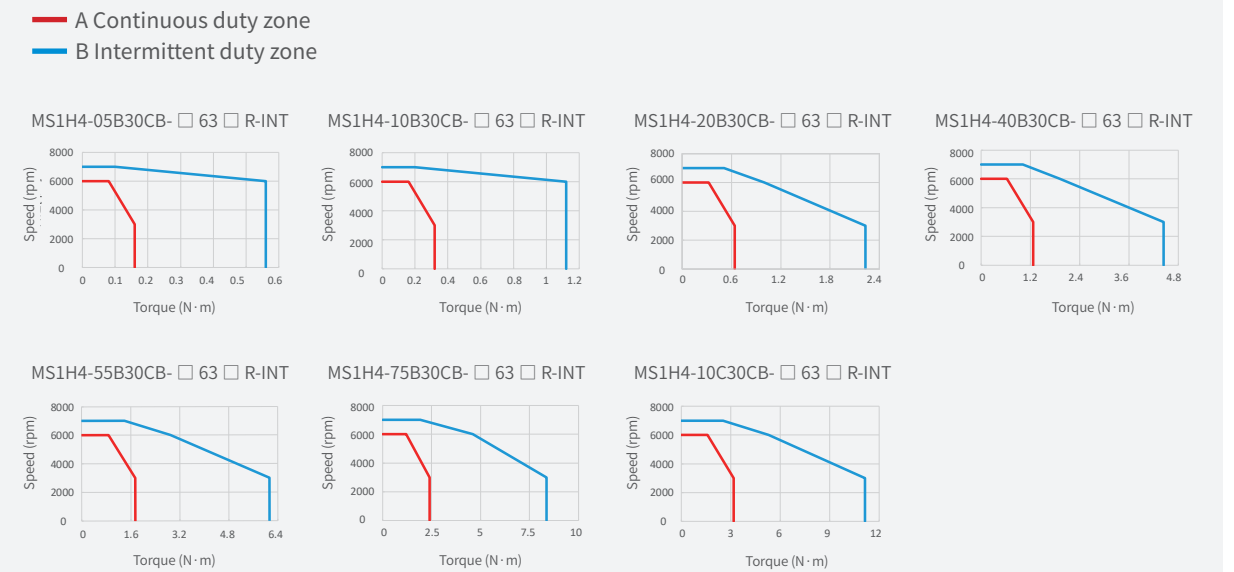

Torque-Speed Characteristics of MS1-R Motors with 23-bit Encoders

MS1H1
low
inertia,
small
capacity

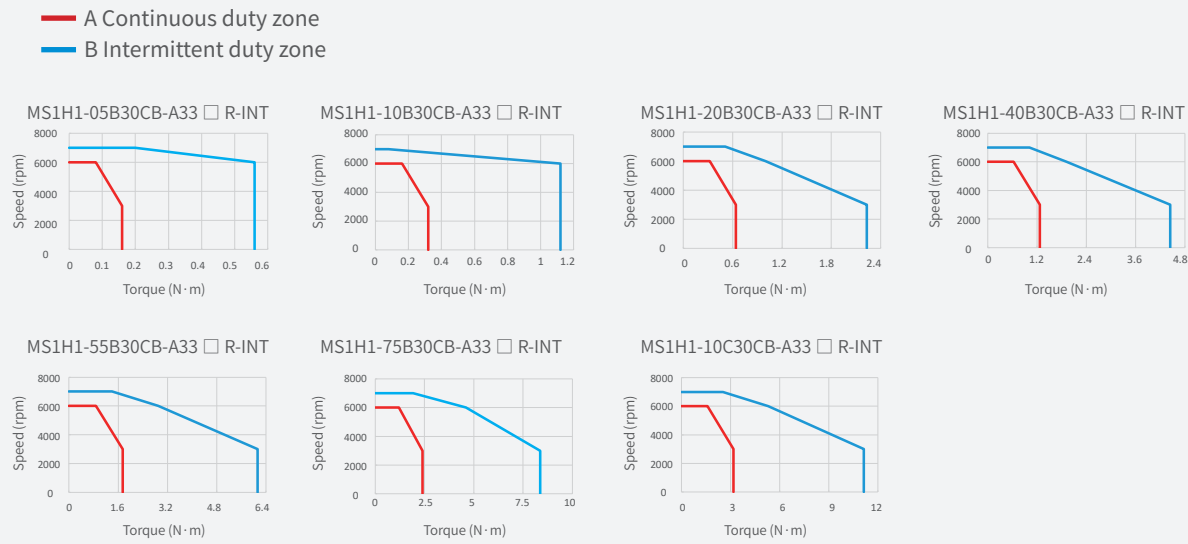

MS1H2
low
inertia,
small
capacity

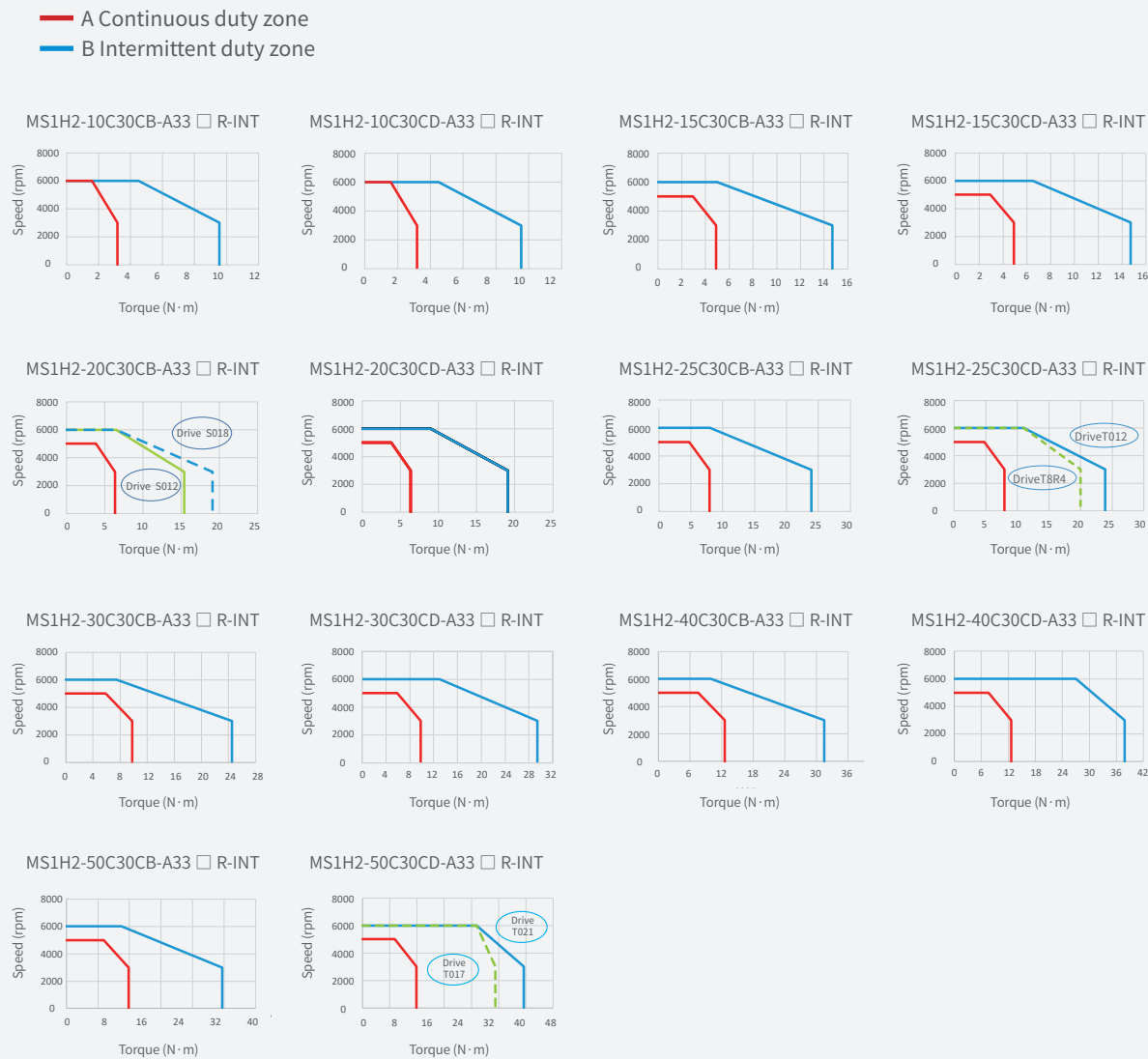

MS1H3
medium
inertia,
medium
capacity

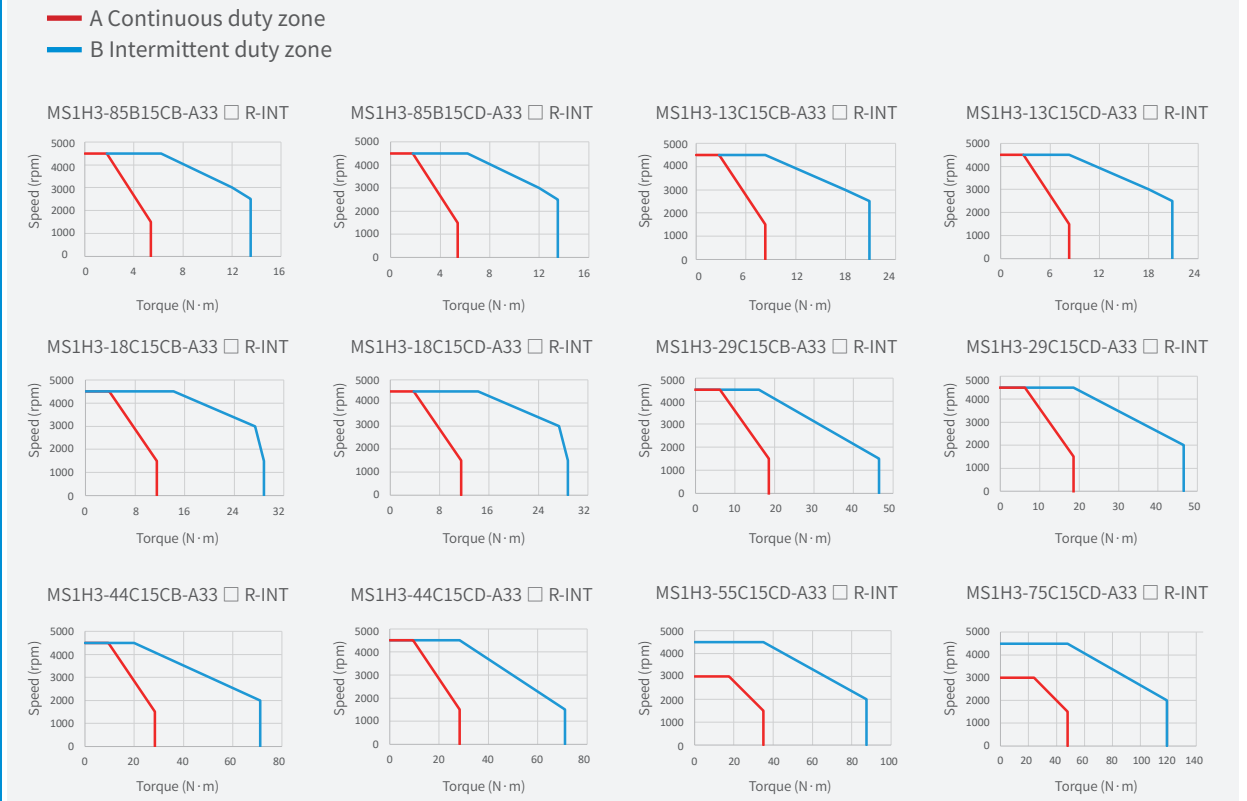

MS1H4
medium
inertia,
small
capacity

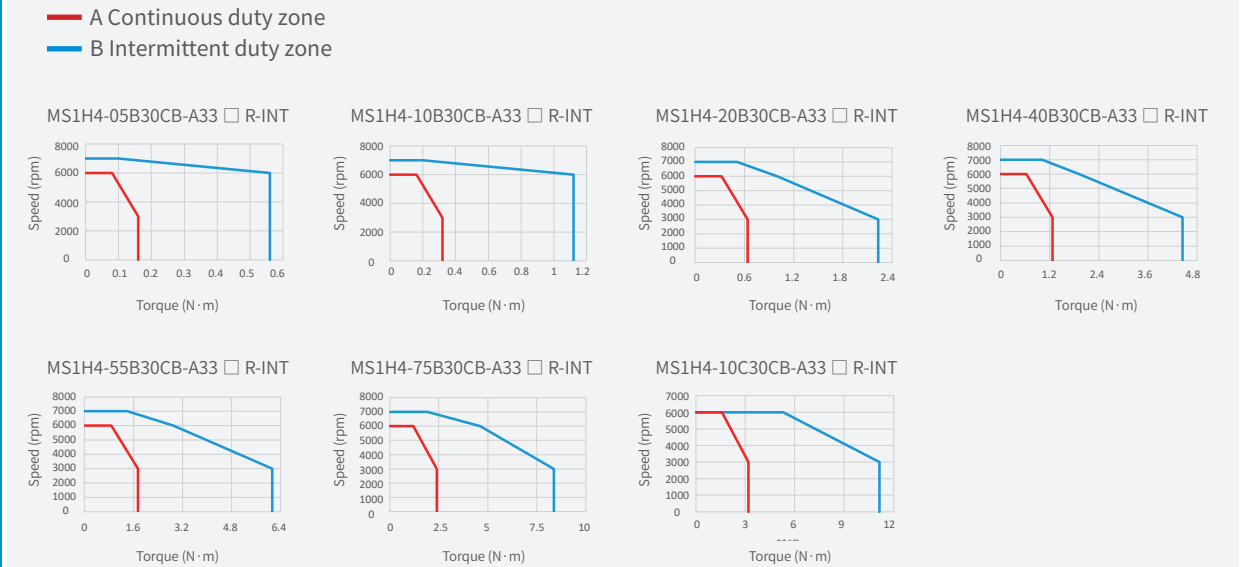

Dimensions of MS1-R Series H1/H4 Motors

Flange size 40

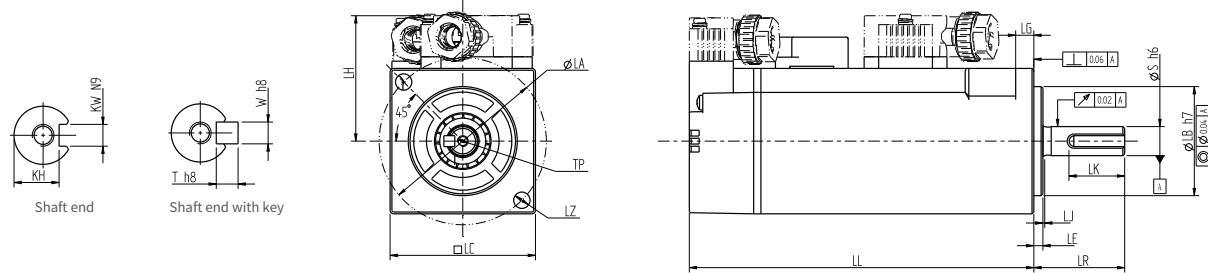

Flange size 60/80

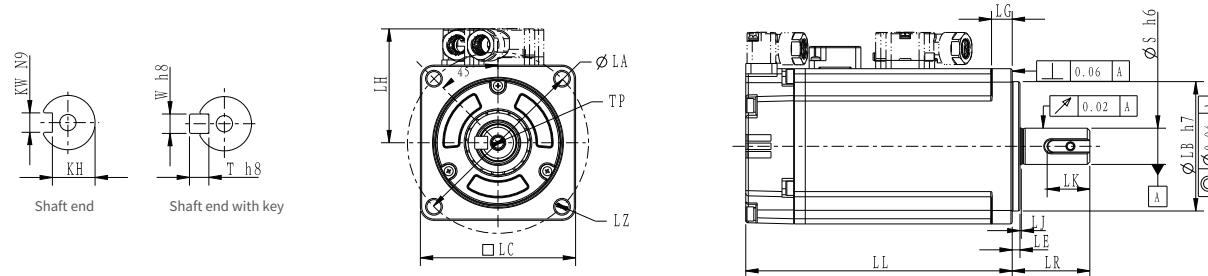

Motor Model	LC (mm)	LL (mm)	LR (mm)	LA (mm)	LZ (mm)	LH (mm)	LG (mm)	LE (mm)	LJ (mm)	LB (mm)	
Flange size 40	MS1H1-05B30CB- □□3 □ R-INT ^[1]	40	54.5 (81.8)	25±0.5	46	2-Ø4.5	34.5	5	2.5±0.5	0.5±0.35	Ø30h7 ⁰ _{-0.021}
	MS1H1-10B30CB- □□3 □ R-INT ^[1]	40	67 (94.3)	25±0.5	46	2-Ø4.5	34.5	5	2.5±0.5	0.5±0.35	Ø30h7 ⁰ _{-0.021}
	MS1H4-05B30CB- □□3 □ R-INT ^[2]	40	51 (78.3)	25±0.5	46	2-Ø4.5	34.5	5	2.5±0.5	0.5±0.35	Ø30h7 ⁰ _{-0.021}
	MS1H4-05B30CB- □□3 □ R-INT ^[3]	40	53.7 (81)	25±0.5	46	2-Ø4.5	34.5	5	2.5±0.5	0.5±0.35	Ø30h7 ⁰ _{-0.021}
	MS1H4-10B30CB- □□3 □ R-INT ^[2]	40	62 (89.3)	25±0.5	46	2-Ø4.5	34.5	5	2.5±0.5	0.5±0.35	Ø30h7 ⁰ _{-0.021}
	MS1H4-10B30CB- □□3 □ R-INT ^[3]	40	64.7 (92)	25±0.5	46	2-Ø4.5	34.5	5	2.5±0.5	0.5±0.35	Ø30h7 ⁰ _{-0.021}

Motor Model	S (mm)	TP (mm)	LK (mm)	KH (mm)	KW (mm)	W (mm)	T (mm)	Weight ^[4] (kg)
Flange size 40	MS1H1-05B30CB- □□3 □ R-INT	8	M3×6	16.5 ⁰ _{-0.53}	6.2 ⁰ _{-0.1}	3	3	0.26 (0.43)
	MS1H1-10B30CB- □□3 □ R-INT	8	M3×6	16.5 ⁰ _{-0.53}	6.2 ⁰ _{-0.1}	3	3	0.35 (0.52)
	MS1H4-05B30CB- □□3 □ R-INT	8	M3×6	16.5 ⁰ _{-0.53}	6.2 ⁰ _{-0.1}	3	3	0.24 (0.40)
	MS1H4-05B30CB- □□3 □ R-INT	8	M3×6	16.5 ⁰ _{-0.53}	6.2 ⁰ _{-0.1}	3	3	0.26 (0.42)
	MS1H4-10B30CB- □□3 □ R-INT	8	M3×6	16.5 ⁰ _{-0.53}	6.2 ⁰ _{-0.1}	3	3	0.32 (0.48)
	MS1H4-10B30CB- □□3 □ R-INT	8	M3×6	16.5 ⁰ _{-0.53}	6.2 ⁰ _{-0.1}	3	3	0.34 (0.50)

Motor Model	LC (mm)	LL (mm)	LR (mm)	LA (mm)	LZ (mm)	LH (mm)	LG (mm)	LE (mm)	LJ (mm)	LB (mm)	
Flange size 60/80	MS1H1-20B30CB- □□3 □ R-INT	60	75.5 (103)	30±0.5	70	4-Ø5.5	44	8	3±0.5	0.5±0.35	Ø50h7 ⁰ _{-0.025}
	MS1H1-40B30CB- □□3 □ R-INT	60	93 (121)	30±0.5	70	4-Ø5.5	44	8	3±0.5	0.5±0.35	Ø50h7 ⁰ _{-0.021}
	MS1H1-55B30CB- □□3 □ R-INT	80	96.7 (/)	35±0.5	90	4-Ø7	54	7.5	3±0.5	0.5±0.35	Ø70h7 ⁰ _{-0.03}
	MS1H1-75B30CB- □□3 □ R-INT	80	107.3 (141.5)	35±0.5	90	4-Ø7	54	7.5	3±0.5	0.5±0.35	Ø70h7 ⁰ _{-0.03}
	MS1H1-10C30CB- □□3 □ R-INT	80	119.2 (153.4)	35±0.5	90	4-Ø7	54	7.5	3±0.5	0.5±0.35	Ø70h7 ⁰ _{-0.03}
	MS1H4-20B30CB- □□3 □ R-INT	60	73.5 (101.1)	30±0.5	70	4-Ø5.5	44	8	3±0.5	0.5±0.35	Ø50h7 ⁰ _{-0.025}
	MS1H4-40B30CB- □□3 □ R-INT	60	92 (119.8)	30±0.5	70	4-Ø5.5	44	8	3±0.5	0.5±0.35	Ø50h7 ⁰ _{-0.021}
	MS1H4-55B30CB- □□3 □ R-INT	80	96.7 (/)	35±0.5	90	4-Ø7	54	8	3±0.5	0.5±0.35	Ø70h7 ⁰ _{-0.03}
	MS1H4-75B30CB- □□3 □ R-INT	80	107.3 (140.5)	35±0.5	90	4-Ø7	54	8	3±0.5	0.5±0.35	Ø70h7 ⁰ _{-0.03}
	MS1H4-10C30CB- □□3 □ R-INT	80	118.7 (153.2)	35±0.5	90	4-Ø7	54	8	3±0.5	0.5±0.35	Ø70h7 ⁰ _{-0.03}

Motor Model	S (mm)	TP (mm)	LK (mm)	KH (mm)	KW (mm)	W (mm)	T (mm)	Weight (kg)
Flange size 60/80	MS1H1-20B30CB- □□3 □ R-INT	14	M5×8	16.5 ⁰ _{-0.53}	11 ⁰ _{-0.1}	5	5	0.80 (1.17)
	MS1H1-40B30CB- □□3 □ R-INT	14	M5×8	16.5 ⁰ _{-0.53}	11 ⁰ _{-0.1}	5	5	1.11 (1.48)
	MS1H1-55B30CB- □□3 □ R-INT	19	M6×20	25 ⁰ _{-0.62}	15.5 ⁰ _{-0.1}	6	6	1.88 (/)
	MS1H1-75B30CB- □□3 □ R-INT	19	M6×20	25 ⁰ _{-0.62}	15.5 ⁰ _{-0.1}	6	6	2.22 (2.88)
	MS1H1-10C30CB- □□3 □ R-INT	19	M6×20	25 ⁰ _{-0.62}	15.5 ⁰ _{-0.1}	6	6	2.61 (3.27)
	MS1H4-20B30CB- □□3 □ R-INT	14	M5×8	16.5 ⁰ _{-0.53}	11 ⁰ _{-0.1}	5	5	0.78 (1.16)
	MS1H4-40B30CB- □□3 □ R-INT	14	M5×8	16.5 ⁰ _{-0.53}	11 ⁰ _{-0.1}	5	5	1.11 (1.48)
	MS1H4-55B30CB- □□3 □ R-INT	19	M6×20	25 ⁰ _{-0.62}	15.5 ⁰ _{-0.1}	6	6	1.85 (/)
	MS1H4-75B30CB- □□3 □ R-INT	19	M6×20	25 ⁰ _{-0.62}	15.5 ⁰ _{-0.1}	6	6	2.18 (2.82)
	MS1H4-10C30CB- □□3 □ R-INT	19	M6×20	25 ⁰ _{-0.62}	15.5 ⁰ _{-0.1}	6	6	2.55 (2.9)

Note : [1] Flange size 40mm with H1 type motors are not equipped with an oil seal.

[2] Flange size 40mm without oil seal types.

[3] Flange size 40mm with oil seal types.

[4] Values in the parentheses are for the motor with brake types.

Dimensions of MS1-R Series H2/H3 Motors

Flange size 100

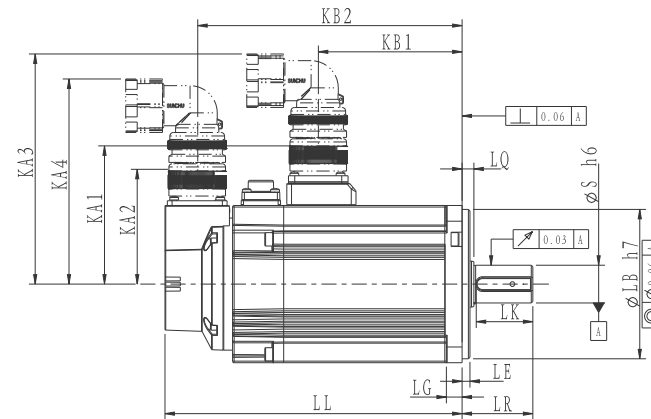
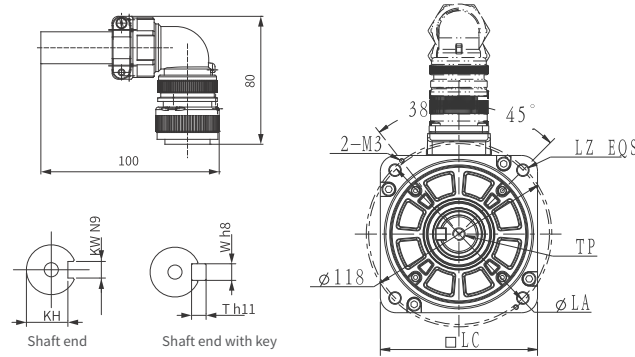

Flange size 130/180

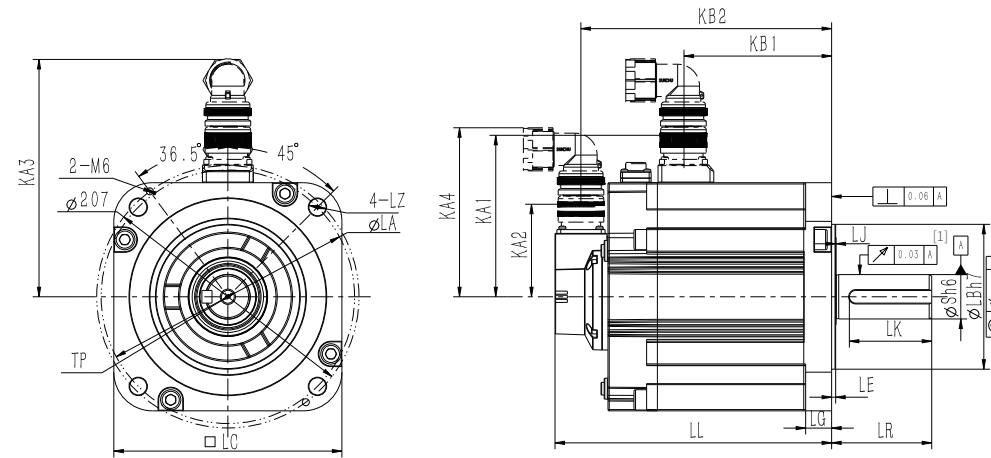
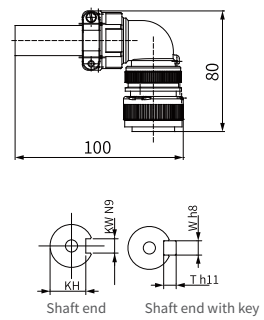

Motor Model		LC (mm)	LL (mm)	LR (mm)	LA (mm)	LZ (mm)	KA1 (mm)	KB1 (mm)	KA2 (mm)	KB2 (mm)	LG (mm)	LE (mm)
Flange size 100	MS1H2-10C30CB- □□ 3 □ R-INT	100	144	45±1	115	4 - Ø7	88	75	73	123.5 (151.5)	10	5±0.3
	MS1H2-10C30CD- □□ 3 □ R-INT		(172)									
	MS1H2-15C30CB- □□ 3 □ R-INT		161									
	MS1H2-15C30CD- □□ 3 □ R-INT		(189)									
	MS1H2-20C30CB- □□ 3 □ R-INT		177									
	MS1H2-20C30CD- □□ 3 □ R-INT		(205)									
MS1H2-25C30CB- □□ 3 □ R-INT	195											
MS1H2-25C30CD- □□ 3 □ R-INT	(223)											

Motor Model		LQ (mm)	LB (mm)	S (mm)	TP (mm)	LK (mm)	KH (mm)	KW (mm)	W (mm)	T (mm)	Weight ^[2] (kg)
Flange size 100	MS1H2-10C30CB- □□ 3 □ R-INT	7.5±0.75	Ø95h7 ⁰ _{-0.035}	24	M8×16	35 ⁰ _{-0.62}	20 ⁰ _{-0.2}	8	8	7	3.85
	MS1H2-10C30CD- □□ 3 □ R-INT										(4.9)
	MS1H2-15C30CB- □□ 3 □ R-INT										4.65
	MS1H2-15C30CD- □□ 3 □ R-INT										(5.75)
	MS1H2-20C30CB- □□ 3 □ R-INT										5.5
	MS1H2-20C30CD- □□ 3 □ R-INT										(6.55)
MS1H2-25C30CB- □□ 3 □ R-INT	6.3										
MS1H2-25C30CD- □□ 3 □ R-INT	(7.35)										

Motor Model		LC (mm)	LL (mm)	LR (mm)	LA (mm)	LZ (mm)	KA1 (mm)	KB1 (mm)	KA2 (mm)	KB2 (mm)	LG (mm)	LE (mm)
Flange size 130	MS1H2-30C30CB- □□ 3 □ R-INT	130	198	63±1	145	4 - Ø9	102.4	127.5	73	177.5 (202.5)	12	6±0.3
	MS1H2-30C30CD- □□ 3 □ R-INT		(223)									
	MS1H2-40C30CB- □□ 3 □ R-INT		236									
	MS1H2-40C30CD- □□ 3 □ R-INT		(261)									
	MS1H2-50C30CB- □□ 3 □ R-INT		274									
	MS1H2-50C30CD- □□ 3 □ R-INT		(299)									
MS1H3-85B15CB- □□ 3 □ R-INT	142											
MS1H3-85B15CD- □□ 3 □ R-INT	(167)											
MS1H3-13C15CB- □□ 3 □ R-INT	157											
MS1H3-13C15CD- □□ 3 □ R-INT	(182)											
MS1H3-18C15CB- □□ 3 □ R-INT	172											
MS1H3-18C15CD- □□ 3 □ R-INT	(197)											

Motor Model		LJ (mm)	LB (mm)	S (mm)	TP (mm)	LK (mm)	KH (mm)	KW (mm)	W (mm)	T (mm)	Weight (kg)
Flange size 130	MS1H2-30C30CB- □□ 3 □ R-INT	0.5±0.75	Ø110h7 ⁰ _{-0.035}	28	M8×20	53 ⁰ _{-0.62}	24 ⁰ _{-0.2}	8	8	7	10.0
	MS1H2-30C30CD- □□ 3 □ R-INT										(11.9)
	MS1H2-40C30CB- □□ 3 □ R-INT										13.2
	MS1H2-40C30CD- □□ 3 □ R-INT										(15.1)
	MS1H2-50C30CB- □□ 3 □ R-INT										16.5
	MS1H2-50C30CD- □□ 3 □ R-INT										(18.25)
MS1H3-85B15CB- □□ 3 □ R-INT	5.8										
MS1H3-85B15CD- □□ 3 □ R-INT	(7.7)										
MS1H3-13C15CB- □□ 3 □ R-INT	7.1										
MS1H3-13C15CD- □□ 3 □ R-INT	(8.9)										
MS1H3-18C15CB- □□ 3 □ R-INT	8.5										
MS1H3-18C15CD- □□ 3 □ R-INT	(10.3)										

Motor Model		LC (mm)	LL (mm)	LR (mm)	LA (mm)	LZ (mm)	KA1 (mm)	KB1 (mm)	KA2 (mm)	KB2 (mm)	LG (mm)	LE (mm)
Flange size 180	MS1H3-29C15CB- □□ 3 □ R-INT	180	161	79±1	200	4-Ø13.5	127.4	93.5	73	140.5 (174.3)	22	3.2±0.3
	MS1H3-29C15CD- □□ 3 □ R-INT		(194.8)									
	MS1H3-44C15CB- □□ 3 □ R-INT		184.5									
	MS1H3-44C15CD- □□ 3 □ R-INT		(218.3)									
	MS1H3-55C15CB- □□ 3 □ R-INT		208									
	MS1H3-55C15CD- □□ 3 □ R-INT		(241.8)									
MS1H3-75C15CB- □□ 3 □ R-INT	255											
MS1H3-75C15CD- □□ 3 □ R-INT	(288.8)											

Motor Model		LJ (mm)	LB (mm)	S (mm)	TP (mm)	LK (mm)	KH (mm)	KW (mm)	W (mm)	T (mm)	Weight (kg)
Flange size 180	MS1H3-29C15CB- □□ 3 □ R-INT	0.5±0.75	Ø114.3h7 ⁰ _{-0.035}	35	M12×25	64 ⁰ _{-0.74}	30 ⁰ _{-0.2}	10	10	8	13.8
	MS1H3-29C15CD- □□ 3 □ R-INT										(17.9)
	MS1H3-44C15CB- □□ 3 □ R-INT										17.4
	MS1H3-44C15CD- □□ 3 □ R-INT										(21.9)
	MS1H3-55C15CB- □□ 3 □ R-INT										21.7
	MS1H3-55C15CD- □□ 3 □ R-INT										(25.9)
MS1H3-75C15CB- □□ 3 □ R-INT	29										
MS1H3-75C15CD- □□ 3 □ R-INT	(33.2)										

Note:

[1] The radial runout on the shaft extension end of the 130H3-flange motors is: $\sqrt{0.02A}$

[2] Values in the parentheses are for the motor with brake.

Axial/Radial Allowable Load

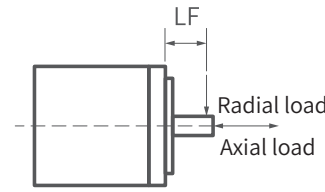

Motor Model	Flange Size (mm)	LF (mm)	Allowable Radial Load (N)	Allowable Axial Load (N)
MS1H1-05B30CB- □□ 3 □ R-INT MS1H1-10B30CB- □□ 3 □ R-INT MS1H4-05B30CB- □□ 3 □ R-INT MS1H4-10B30CB- □□ 3 □ R-INT	40	20	78	54
MS1H1-20B30CB- □□ 3 □ R-INT MS1H1-40B30CB- □□ 3 □ R-INT MS1H4-20B30CB- □□ 3 □ R-INT MS1H4-40B30CB- □□ 3 □ R-INT	60	25	245	74
MS1H1-55B30CB- □□ 3 □ R-INT MS1H1-75B30CB- □□ 3 □ R-INT MS1H1-10C30CB- □□ 3 □ R-INT MS1H4-55B30CB- □□ 3 □ R-INT MS1H4-75B30CB- □□ 3 □ R-INT MS1H4-10C30CB- □□ 3 □ R-INT	80	35	392	147
MS1H2-10C30CB- □□ 3 □ R-INT MS1H2-10C30CD- □□ 3 □ R-INT MS1H2-15C30CB- □□ 3 □ R-INT MS1H2-15C30CD- □□ 3 □ R-INT MS1H2-20C30CB- □□ 3 □ R-INT MS1H2-20C30CD- □□ 3 □ R-INT MS1H2-25C30CB- □□ 3 □ R-INT MS1H2-25C30CD- □□ 3 □ R-INT	100	45	686	196
MS1H2-30C30CB- □□ 3 □ R-INT MS1H2-30C30CD- □□ 3 □ R-INT MS1H2-40C30CB- □□ 3 □ R-INT MS1H2-40C30CD- □□ 3 □ R-INT MS1H2-50C30CB- □□ 3 □ R-INT MS1H2-50C30CD- □□ 3 □ R-INT	130	63	1176	392
MS1H3-85B15CB- □□ 3 □ R-INT MS1H3-85B15CD- □□ 3 □ R-INT MS1H3-13C15CB- □□ 3 □ R-INT MS1H3-13C15CD- □□ 3 □ R-INT MS1H3-18C15CB- □□ 3 □ R-INT MS1H3-18C15CD- □□ 3 □ R-INT	130	55	686	196
MS1H3-29C15CB- □□ 3 □ R-INT MS1H3-29C15CD- □□ 3 □ R-INT MS1H3-44C15CB- □□ 3 □ R-INT MS1H3-44C15CD- □□ 3 □ R-INT	180	79	1470	490
MS1H3-55C15CD- □□ 3 □ R-INT MS1H3-75C15CD- □□ 3 □ R-INT	180	113	1764	588

Technical Data for the Motor with Brake

Motor Model	Holding Torque (N·m)	Supply Voltage (V DC) ±10%	Rated Power (W)	Coil Resistance (Ω) ±7%	Exciting Current (A)	Release Time (ms)	Apply Time (ms)	Backlash (°)
MS1H1-05B/10B MS1H4-05B/10B	0.32	24	6.1	94.4	0.25	≤ 20	≤ 40	≤ 1.5
MS1H1/4-20B/40B	1.5	24	7.6	75.79	0.32	≤ 20	≤ 60	≤ 1
MS1H1/4-75B/10C	3.2	24	10	57.6	0.42	≤ 40	≤ 60	≤ 1
MS1H2-10C/15C/20C/25C	8	24	17.6	32.73	0.73	≤ 40	≤ 100	≤ 1
MS1H2-30C/40C/50C	16.5	24	24	24	1	≤ 60	≤ 120	≤ 1
MS1H3-85B/13C/18C	16.5	24	24	24	1	≤ 60	≤ 120	≤ 1
MS1H3-29C/44C/55C/75C	55	24	31	18.58	1.29	≤ 100	≤ 200	≤ 1

Note:

- The holding brake cannot be used for braking purpose.
- The brake release time and apply time vary with the discharging circuit. Check the actual action delay of the product during use.
- 24 VDC power supplies need to be prepared by users.

Derating Characteristics

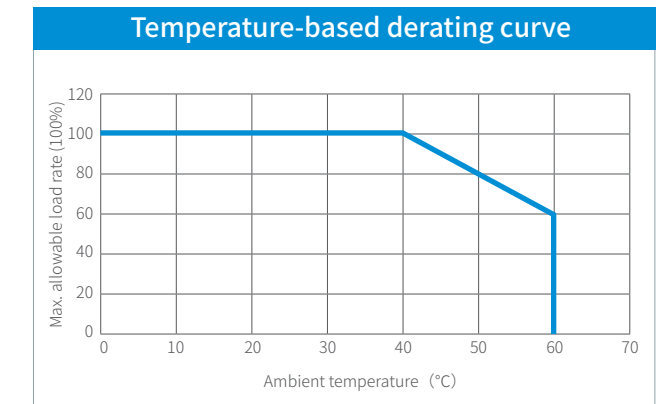
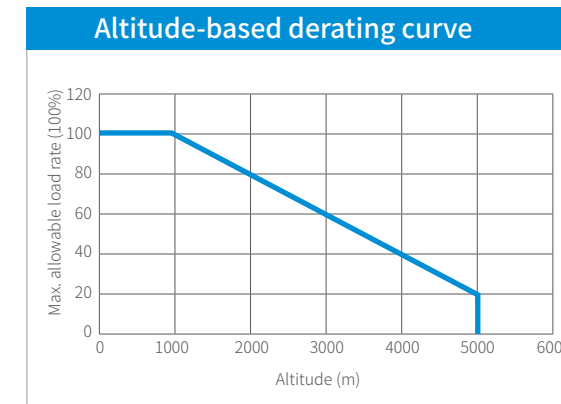

Applicable Cable Selection

Ordering code for power cable

S6-L-M-0 0 1-3.0-T-INT

① ② ③ ④ ⑤ ⑥ ⑦

① Cable type S6-L-B/M: Motion control power cable B: With brake M: Without brake	③ Available motor power 0: Flange size 40/60/80mm 1: Flange size 100/130/180mm 2: Flange size 180mm (motors of 4.4kW and above)	⑤ Cable length (m) 3.0: 3 m 5.0: 5 m 10.0: 10 m
② Connector type at drive side 0: U-shaped cable lug 1: Needle-shaped cable lug	④ Connector type at motor side 1: 9-core aviation connector 2: 6-core aviation connector 7: SDC-06T series aviation connector (front outlet) 8: SDC-06T series aviation connector (rear outlet)	⑥ Special requirements T: Flexible cable \geq 10 million times
		⑦ Model type INT: International

Power cable

Motor Model	Cable Name	Cable Model	Cable Length (mm)	Dimension Drawing
MS1H1/ MS1H4 terminal- type motor	Without brake (Front outlet)	S6-L-M107-3.0 (-T) -INT	3000	
		S6-L-M107-5.0 (-T) -INT	5000	
		S6-L-M107-10.0 (-T) -INT	10000	
	With brake (Rear outlet)	S6-L-B107-3.0 (-T) -INT	3000	
		S6-L-B107-5.0 (-T) -INT	5000	
		S6-L-B107-10.0 (-T) -INT	10000	
	Without brake (Front outlet)	S6-L-M108-3.0 (-T) -INT	3000	
		S6-L-M108-5.0 (-T) -INT	5000	
		S6-L-M108-10.0 (-T) -INT	10000	
	With brake (Rear outlet)	S6-L-B108-3.0 (-T) -INT	3000	
		S6-L-B108-5.0 (-T) -INT	5000	
		S6-L-B108-10.0 (-T) -INT	10000	
MS1H2 motors of 3 kW and below/ MS1H3 motors of 1.8 kW and below	Without brake	S6-L-M111-3.0 (-T) -INT	3000	
		S6-L-M111-5.0 (-T) -INT	5000	
		S6-L-M111-10.0 (-T) -INT	10000	
	With brake	S6-L-B111-3.0 (-T) -INT	3000	
		S6-L-B111-5.0 (-T) -INT	5000	
		S6-L-B111-10.0 (-T) -INT	10000	

Applicable Cable Selection

Power cable

Motor Model	Cable Name	Cable Model	Cable Length (mm)	Dimension Drawing
MS1H2 motors of 4 kW/5 kW	Without brake	S6-L-M011-3.0 (-T) -INT	3000	
		S6-L-M011-5.0 (-T) -INT	5000	
		S6-L-M011-10.0 (-T) -INT	10000	
	With brake	S6-L-B011-3.0 (-T) -INT	3000	
		S6-L-B011-5.0 (-T) -INT	5000	
		S6-L-B011-10.0 (-T) -INT	10000	
MS1H3 motors of 2.9 kW	Without brake	S6-L-M112-3.0 (-T) -INT	3000	
		S6-L-M112-5.0 (-T) -INT	5000	
		S6-L-M112-10.0 (-T) -INT	10000	
	With brake	S6-L-B112-3.0 (-T) -INT	3000	
		S6-L-B112-5.0 (-T) -INT	5000	
		S6-L-B112-10.0 (-T) -INT	10000	
MS1H3 motors of 4.4 kW and above	Without brake	S6-L-M022-3.0 (-T) -INT	3000	
		S6-L-M022-5.0 (-T) -INT	5000	
		S6-L-M022-10.0 (-T) -INT	10000	
	With brake	S6-L-B022-3.0 (-T) -INT	3000	
		S6-L-B022-5.0 (-T) -INT	5000	
		S6-L-B022-10.0 (-T) -INT	10000	

Note:

- MS1-R series motors share the same cables as MS1-Z series motors.
- For more information on cables, see section Cable Specifications and Models in the hardware guide of the servo drive.
- Motor with power 50W, the power cables must select the rear outlet model as shown on the right. This is to prevent the mounting flange face from be disturbed by the power cable. For detailed cable model selection, please refer to the servo drive hardware guide.
- Power cable with shielded as standard.
- -T: Flexible cable is optional.
- Encoder cable with shielded as datandard.

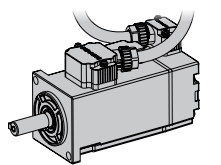

Applicable Cable Selection

Ordering code for Encoder cable

S6-L-P-1 2 1-3.0-T-INT

① ② ③ ④ ⑤ ⑥ ⑦

① Cable type S6-L-P: Motion control encoder cable	③ Encoder 2: Communication-type multi-turn absolute encoder	⑤ Cable length (m) 3.0: 3 m 5.0: 5 m 10.0: 10 m
② Connector type at drive side 1: USB	④ Connector type at motor side 1: 9-core aviation connector 4: SDC-06T series aviation connector (front outlet) 5: SDC-06T series aviation connector (rear outlet)	⑥ Special requirements T: Flexible cable ≥ 10 million times
		⑦ Model type INT: International

Encoder cable

Motor Model	Cable Name	Cable Model	Cable Length (mm)	Dimension Drawing		
MS1H1/ MS1H4 terminal- type motors	Front outlet	Single-turn absolute encoder	S6-L-P114-3.0 (-T) -INT	3000		
		S6-L-P114-5.0 (-T) -INT	5000			
		S6-L-P114-10.0 (-T) -INT	10000			
		Multi-turn absolute encoder	S6-L-P124-3.0 (-T) -INT	3000		
		S6-L-P124-5.0 (-T) -INT	5000			
		S6-L-P124-10.0 (-T) -INT	10000			
	Rear outlet	Single-turn absolute encoder	S6-L-P115-3.0 (-T) -INT	3000		
		S6-L-P115-5.0 (-T) -INT	5000			
		S6-L-P115-10.0 (-T) -INT	10000			
		Multi-turn absolute encoder	S6-L-P125-3.0 (-T) -INT	3000		
		S6-L-P125-5.0 (-T) -INT	5000			
		S6-L-P125-10.0 (-T) -INT	10000			
MS1H2/ MS1H3 motors	Single-turn absolute encoder	S6-L-P111-3.0 (-T) -INT	3000			
		S6-L-P111-5.0 (-T) -INT	5000			
		S6-L-P111-10.0 (-T) -INT	10000			
	Multi-turn absolute encoder	S6-L-P121-3.0 (-T) -INT	3000			
		S6-L-P121-5.0 (-T) -INT	5000			
		S6-L-P121-10.0 (-T) -INT	10000			

Note:

- MS1-R series motors share the same cables as MS1-Z series motors.
- For more information on cables, see section Cable Specifications and Models in the hardware guide of the servo drive.
- Power cable with shielded as standard.
- -T: Flexible cable is optional.
- Encoder cable with shielded as datandard.

Connector Kits

Overview of connector kits

Name	Model	Outline Drawing
Battery box kit (battery-less)	S6-C4A-NB	
Battery kit	S6-C4A	
CN1 terminal (DB26)	S6-C74	
CN7 terminal (DB15)	S6-C6	
Shield bracket	S6-C25 S6-C25 (optional for size A to size C) S6-C27 S6-C27 (optional for size D to size E)	
MS1H1/MS1H4 terminal-type motor connector	S6-C26	
MS1H2/MS1H3 motor (1.8 kW and below) connector	S6-C29	
MS1H3 motor (2.9kW and above) connector	S6-C39	