

Unpacking Instructions of IR-TS Series Ceiling-Mounted SCARA Robots

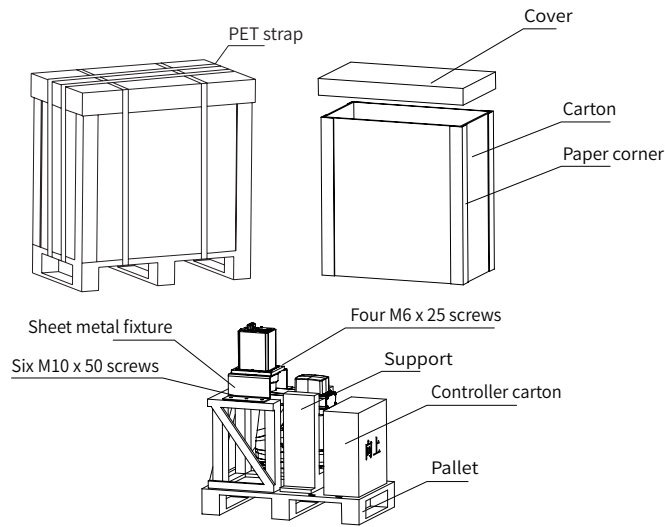

19012461A00

Step 1. Unpack the carton.
 Cut the PET strap using scissors or a utility knife, and remove the cover of the carton.
 Note: Wear protective gloves to prevent cuts.
 Tools: Protective gloves, scissors/utility knife.



Step 2. Remove the outer packaging of the robot controller.
 1) Cut off the strap of the controller carton with scissors.
 2) Move the carton from the pallet to an open ground. Pay attention to the orientation indication on the carton.
 3) Cut the sealing tape of the carton with scissors and then open the carton.
 4) Remove the controller from the carton by grasping the handle holes on both sides of the controller or holding the bottom of the controller, and move the controller to the target location.
 Tools: Scissors/utility knife.

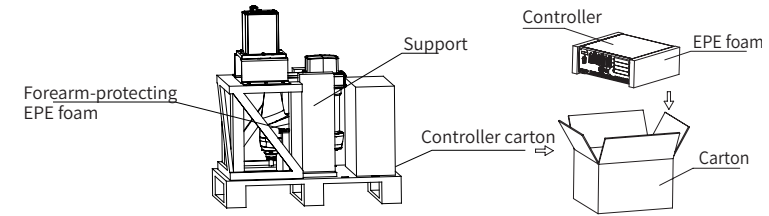

Step 3. Remove the support and take out the robot.
 1) Remove the screws from the support with a claw hammer and then remove the support.
 2) Remove the M6 x 25 screws on the robot base with an Allen wrench.
 Note: Hold the robot to prevent it from tilting.
 3) Lift and take out the robot without interference between the robot and the sheet metal fixture, and move the robot to the target location.
 Note: Remove the support with care to avoid collision with the robot.
 Tools: Allen wrench, claw hammer.

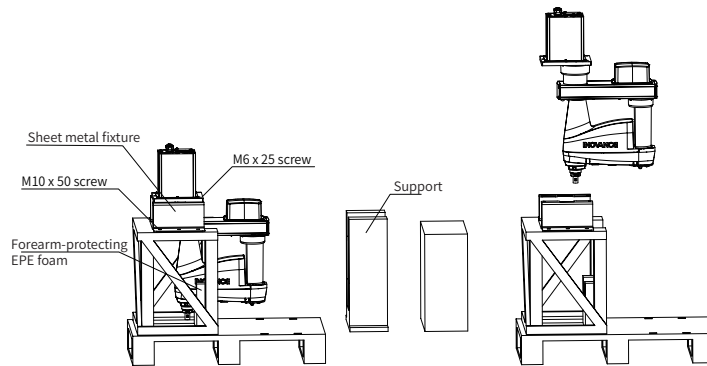

Step 4. Place the robot.
 Take out the robot and place it correctly.

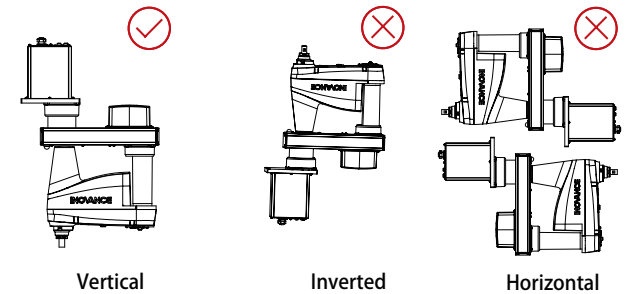

1. If necessary, pack the robot by reversing the steps described above. Wear protective gloves to prevent cuts and work carefully to avoid damaging the robot.
2. It is prohibited to rotate the J1 and J2 joints more than one turn in the reverse direction relative to the robot's state as it was delivered. Failure to comply may cause damage to the internal wiring harness!