



## MD580 Series Low-Voltage High-Performance Engineering AC Drive Hardware Guide



Industrial  
Automation



Intelligent  
Elevator



New Energy  
Vehicle



Industrial  
Robot



Rail  
Transit



Data code 19011706A02

# Preface

## Introduction

The MD580 series is a low-voltage high-performance engineering AC drive that can control three-phase AC permanent magnet synchronous motors and asynchronous motors. Adopting the high-performance vector control technology, the MD580 series features high torque output at a low speed, excellent dynamic characteristics, superior overload capabilities, and stable performance. It provides rich and powerful combined functions, such as user programmable, software monitoring, and communication bus functions, and supports multiple encoder types.

This guide describes the system composition, technical specifications, components, dimensions, options (including installation accessories, cables, and peripheral electrical components), expansion cards, routine maintenance and repair, certifications, and standards of the AC drive.

## More documents

Document Name	Document Code	Description
MD580 Series Low-voltage High-performance Engineering AC Drive Hardware Guide	19011706	This guide describes the system composition, technical specifications, components, dimensions, options (including installation accessories, cables, and peripheral electrical components), expansion cards, routine maintenance and repair, certifications, and standards of the AC drive.
MD580 Series Low-voltage High-performance Engineering AC Drive Installation Guide	19012111	This guide describes the installation dimensions, space design, specific installation steps, wiring requirements, routing requirements, option installation requirements, and troubleshooting of common EMC-related problems.
MD580 Series Low-voltage High-performance Engineering AC Drive Communication Guide	19011708	This guide describes the composition, size, installation, electrical connection, and parameter configuration of the communication expansion card.
MD580 Series Low-voltage High-performance Engineering AC Drive Function Guide	19011709	This guide describes function applications, fault codes, and parameters of the AC drive.
MD580 Series Low-voltage High-performance Engineering AC Drive Commissioning Guide	19012184	This guide describes the parameters, troubleshooting, operating panel, commissioning software, commissioning flowchart, and commissioning procedure.

## Revision History

Date	Version	Description
August 2023	A02	<ul style="list-style-type: none"> <li>● Added section 3.5.6 EtherCAT Industrial Ethernet Communication.</li> <li>● Added section 3.5.7 EtherNet/IP Industrial Ethernet Communication.</li> <li>● Updated section 4.1 List of Options</li> <li>● Updated the selection table of AC input reactors in section 4.3.2 AC Input Reactor.</li> <li>● Updated the selection table of AC output reactors in section 4.3.7 Output Reactor.</li> <li>● Updated section 4.5 Expansion Card.</li> <li>● Added section 4.6 Safe Motor Temperature Detection Card.</li> <li>● Added section 4.7 I/O Card.</li> <li>● Added section 4.8 PG Card.</li> </ul>
November 2022	A01	<ul style="list-style-type: none"> <li>● Added section 2.5.2 Through-hole Mounting (T1 to T9).</li> <li>● Added section 2.5.3 In-Cabinet Mounting (T10 to T12).</li> <li>● Updated section 4.1 List of Options.</li> <li>● Added section 4.2.4 Through-hole Mounting Bracket.</li> </ul>
March 2022	A00	First release

## Access to the Guide

This guide is not delivered with the product. You can obtain the PDF version in the following ways:

- Visit <http://www.inovance.com>, go to Support > Download, search by keyword, and then download the PDF file.
- Scan the QR code on the product with your smart phone.
- Scan the QR code below to install the app, where you can search for and download manuals.



## Warranty

Inovance provides warranty service within the warranty period (as specified in your order) for any fault or damage that is not caused by improper operation of the user. You will be charged for any repair work after the warranty period expires.

Within the warranty period, maintenance fee will be charged for the following damage:

- Damage caused by operations not following the instructions in the user guide
- Damage caused by fire, flood, or abnormal voltage
- Damage caused by unintended use of the product
- Damage caused by use beyond the specified scope of application of the product
- Damage or secondary damage caused by force majeure (natural disaster, earthquake, and lightning strike)

The maintenance fee is charged according to the latest Price List of Inovance. If otherwise agreed upon, the terms and conditions in the agreement shall prevail.

# Table of Contents

Preface .....	1
Product Models .....	7
Fundamental Safety Instructions .....	8
1 Product Information .....	15
1.1 Product Positioning and Characteristics .....	15
1.2 Nameplate and Model .....	16
1.3 Technical Data .....	17
1.3.1 Electrical Specifications .....	17
1.3.2 Technical Specifications .....	22
1.4 Components .....	24
1.4.1 Overview .....	24
1.4.2 Components of T1 to T6 Models .....	25
1.4.3 Components of T7 to T9 Models .....	26
1.4.4 Components of T10 to T12 Models .....	27
2 Mechanical Design .....	29
2.1 AC Drive Dimensions .....	29
2.1.1 T1 to T9 Models .....	29
2.1.2 T10 to T12 Models (Without AC Output Reactor) .....	31
2.1.3 T10 to T12 Models (with AC Output Reactor) .....	32
2.2 Installation Precautions .....	32
2.3 Installation Location .....	34
2.3.1 Installation Environment .....	34
2.3.2 Installation Clearance .....	35
2.4 Heat Dissipation Design .....	38
2.5 Installation Mode .....	43
2.5.1 Backplate Mounting .....	43
2.5.2 Through-hole Mounting (T1 to T9) .....	44
2.5.3 In-Cabinet Installation (T10 to T12) .....	45
3 Electrical Design .....	52
3.1 System Application Wiring .....	52
3.1.1 System Connection Diagram .....	52
3.1.2 Electrical Wiring Diagram .....	54
3.2 Basic Electrical Safety Precautions .....	55
3.2.1 Selecting a Power Isolation Device .....	55
3.2.2 Selecting a Main Contactor .....	56
3.2.3 Selecting a Supply Transformer .....	56
3.2.4 Checking Motor Compatibility .....	57
3.2.5 Using a PMSM .....	57

---

3.2.6 Cable Routing Requirements . . . . .	57
3.3 Wiring of the Main Circuit . . . . .	58
3.3.1 Descriptions of Main Circuit Terminals . . . . .	58
3.3.2 Cable Selection . . . . .	60
3.3.3 Circuit Wiring Requirements . . . . .	65
3.3.4 Cable Lug Selection . . . . .	68
3.4 Control Circuit Wiring . . . . .	69
3.4.1 Descriptions of Control Circuit Terminals . . . . .	69
3.4.2 Control Circuit Terminal Wiring . . . . .	75
3.4.3 Control Circuit Wiring Requirements . . . . .	82
3.5 Communication Connection . . . . .	83
3.5.1 CANopen Communication . . . . .	83
3.5.1.1 Overview . . . . .	83
3.5.1.2 Electrical Connection. . . . .	84
3.5.2 Modbus RTU Communication . . . . .	85
3.5.2.1 Overview . . . . .	85
3.5.2.2 Electrical Connection. . . . .	86
3.5.3 PROFIBUS DP Communication . . . . .	87
3.5.3.1 Overview . . . . .	87
3.5.3.2 Electrical Connection. . . . .	87
3.5.4 PROFINET IO Industrial Ethernet Communication . . . . .	93
3.5.4.1 Overview . . . . .	93
3.5.4.2 Electrical Connection. . . . .	93
3.5.5 Modbus TCP Communication . . . . .	95
3.5.5.1 Overview . . . . .	95
3.5.5.2 Electrical Connection. . . . .	96
3.5.6 EtherNet/IP Industrial Ethernet Communication . . . . .	97
3.5.6.1 Overview . . . . .	97
3.5.6.2 Electrical Connection. . . . .	98
3.5.7 EtherCAT Industrial Ethernet Communication . . . . .	99
3.5.7.1 Overview . . . . .	99
3.5.7.2 Electrical Connection. . . . .	100
3.6 Grounding . . . . .	101
3.6.1 Main Circuit . . . . .	101
3.6.2 Grounding the Control Board . . . . .	102
3.6.3 Grounding a Single Device. . . . .	104
3.6.4 Multiple AC Drives. . . . .	105
3.6.5 Grounding the Cabinet System. . . . .	106
3.7 STO Safety Design and Wiring . . . . .	107
4 Option Selection. . . . .	108
4.1 Option List . . . . .	108
4.2 Mounting Accessories . . . . .	113
4.2.1 Bottom Mounting Bracket . . . . .	113
4.2.2 Guide Rails. . . . .	115

4.2.3 U/V/W Output Sid Copper Busbars . . . . .	115
4.2.4 Through-hole Mounting Bracket. . . . .	117
4.3 Peripheral Electrical Devices . . . . .	128
4.3.1 Fuse, Contactor, and Circuit Breaker . . . . .	128
4.3.2 AC Input Reactor . . . . .	131
4.3.3 EMC Filter. . . . .	140
4.3.4 Simple Filter . . . . .	150
4.3.5 Braking Components . . . . .	152
4.3.6 AFE Unit . . . . .	156
4.3.7 Output Reactors . . . . .	159
4.3.8 Magnetic Ring and Magnetic Buckle. . . . .	171
4.4 Operating Panel . . . . .	174
4.5 Expansion Card . . . . .	176
4.5.1 List of Expansion Cards . . . . .	176
4.5.2 Expansion Card Installation. . . . .	177
4.6 Safe Motor Temperature Detection Card . . . . .	178
4.7 I/O Card . . . . .	180
4.8 PG Card . . . . .	183
4.8.1 ABZ Encoder . . . . .	183
4.8.2 Resolver Encoder Card. . . . .	189
4.8.3 Sin-Cos and SSI Dual-Encoder Expansion Card . . . . .	190
4.8.4 ABZ and SSI Dual-Encoder Expansion Card. . . . .	192
5 Routine Maintenance and Repair . . . . .	196
5.1 Routine Maintenance Checklist . . . . .	196
5.2 Periodic Inspection Checklist . . . . .	197
5.3 Replacement of Quick-Wear Parts . . . . .	197
5.3.1 Service Life of Quick-Wear Parts . . . . .	197
5.3.2 Replacing the Fan . . . . .	198
5.4 Storage . . . . .	200
6 Compliance List . . . . .	201
6.1 Compliance List . . . . .	201
6.2 CE Certification . . . . .	201
6.2.1 Precautions for Compliance with European Standards . . . . .	201
6.2.2 Conditions for Compliance with the EMC Directive . . . . .	202
6.2.3 Conditions for Compliance with the LVD . . . . .	203

## Product Models

Table -1 Relationship between product structures and models

Structure	Model (Three-Phase 380 V to 480 V)
T1	MD580-4T2R1B MD580-4T3R1B MD580-4T3R8B MD580-4T5R1B MD580-4T7R2B MD580-4T9B
T2	MD580-4T13B MD580-4T17B
T3	MD580-4T25B MD580-4T32B
T4	MD580-4T37B
T5	MD580-4T45 MD580-4T45B MD580-4T60 MD580-4T60B
T6	MD580-4T75 MD580-4T75B MD580-4T91 MD580-4T91B
T7	MD580-4T112 MD580-4T112B MD580-4T150 MD580-4T150(B)
T8	MD580-4T176 MD580-4T176(B) MD580-4T210 MD580-4T253
T9	MD580-4T304 MD580-4T377
T10	MD580-4T426 MD580-4T426-L MD580-4T465 MD580-4T465-L
T11	MD580-4T520 MD580-4T520-L MD580-4T585 MD580-4T585-L
T12	MD580-4T650 MD580-4T650-L MD580-4T725 MD580-4T725-L MD580-4T820 MD580-4T820-L

# Fundamental Safety Instructions

## Safety Precautions

- This chapter presents essential safety instructions for a proper use of the equipment. Before operating the equipment, read through the guide and comprehend all the safety instructions. Failure to comply with the safety instructions may result in death, severe personal injuries, or equipment damage.
- "CAUTION", "WARNING", and "DANGER" items in the guide only indicate some of the precautions that need to be followed; they just supplement the safety precautions.
- Use this equipment according to the designated environment requirements. Damage caused by improper use is not covered by warranty.
- Inovance shall take no responsibility for any personal injuries or property damage caused by improper usage.

## Safety Levels and Definitions



Indicates that failure to comply with the notice will result in death or severe personal injuries.



Indicates that failure to comply with the notice may result in death or severe personal injuries.



Indicates that failure to comply with the notice may result in minor or moderate personal injuries or equipment damage.

## General Safety Instructions

- Drawings in the guide are sometimes shown without covers or protective guards. Remember to install the covers or protective guards as specified first, and then perform operations in accordance with the instructions.
- The drawings in the guide are shown for illustration only and may be different from the product you purchased.
- Users must take mechanical precautions to protect personal safety and wear protective equipment, such as anti-smashing shoes, safety clothing, safety glasses, protective gloves, and protective sleeves.

**Unpacking** **WARNING**

- Do not install the equipment if you find damage, rust, or signs of use on the equipment or accessories upon unpacking.
- Do not install the equipment if you find water seepage or missing or damaged components upon unpacking.
- Do not install the equipment if you find the packing list does not conform to the equipment you received.

 **CAUTION**

- Check whether the packing is intact and whether there is damage, water seepage, dampness, and deformation before unpacking.
- Unpack the package by following the unpacking sequence. Do not strike the package violently.
- Check whether there is damage, rust, or injuries on the surface of the equipment and equipment accessories before unpacking.
- Check whether the package contents are consistent with the packing list before unpacking.

**Storage and Transportation** **WARNING**

- Large-scale or heavy equipment must be transported by qualified professionals using specialized hoisting equipment. Failure to comply may result in personal injuries or equipment damage.
- Before hoisting the equipment, ensure the equipment components such as the front cover and terminal blocks are secured firmly with screws. Loosely-connected components may fall off and result in personal injuries or equipment damage.
- Never stand or stay below the equipment when the equipment is being hoisted by the hoisting equipment.
- When hoisting the equipment with a steel rope, ensure the equipment is hoisted at a constant speed without suffering from vibration or shock. Do not turn the equipment over or let the equipment stay hanging in the air. Failure to comply may result in personal injuries or equipment damage.

 CAUTION

- Handle the equipment with care during transportation and mind your steps to prevent personal injuries or equipment damage.
- When carrying the equipment with bare hands, hold the equipment casing firmly with care to prevent parts from falling. Failure to comply may result in personal injuries.
- Store and transport the equipment based on the storage and transportation requirements. Failure to comply will result in equipment damage.
- Avoid storing or transporting the equipment in environments with water splash, rain, direct sunlight, strong electric field, strong magnetic field, and strong vibration.
- Avoid storing the equipment for more than three months. Long-term storage requires stricter protection and necessary inspections.
- Pack the equipment strictly before transportation. Use a sealed box for long-distance transportation.
- Never transport the equipment with other equipment or materials that may harm or have negative impacts on this equipment.

**Installation**

 DANGER

- The equipment must be operated only by professionals with electrical knowledge. Non-professionals are not allowed.

 WARNING

- Read through the guide and safety instructions before installation.
- Do not install this equipment in places with strong electric or magnetic fields.
- Before installation, check that the mechanical strength of the installation site can bear the weight of the equipment. Failure to comply will result in mechanical hazards.
- Do not wear loose clothes or accessories during installation. Failure to comply may result in an electric shock.
- When installing the equipment in a closed environment (such as a cabinet or casing), use a cooling device (such as a fan or air conditioner) to cool the environment down to the required temperature. Failure to comply may result in equipment over-temperature or a fire.
- Do not retrofit the equipment.
- Do not fiddle with the bolts used to fix equipment components or the bolts marked in red.
- When the equipment is installed in a cabinet or final assembly, a fireproof enclosure providing both electrical and mechanical protections must be provided. The IP rating must meet IEC standards and local laws and regulations.
- Before installing equipments with strong electromagnetic interference, such as a transformer, install a shielding equipment for the equipment to prevent malfunction.
- Install the equipment onto an incombustible object such as a metal. Keep the equipment away from combustible objects. Failure to comply will result in a fire.

 CAUTION

- Cover the top of the equipment with a piece of cloth or paper during installation. This is to prevent unwanted objects such as metal chippings, oil, and water from falling into the equipment and causing faults. After installation, remove the cloth or paper on the top of the equipment to prevent over-temperature caused by poor ventilation due to blocked ventilation holes.
- Resonance may occur when the equipment operating at a constant speed executes variable speed operations. In this case, install the vibration-proof rubber under the motor frame or use the vibration suppression function to reduce resonance.

### Wiring

 DANGER

- Equipment installation, wiring, maintenance, inspection, or parts replacement must be performed only by professionals.
- Before wiring, cut off all the power supplies of the equipment. and wait for at least the time designated on the equipment warning label before further operations because residual voltage still exists after power-off. After waiting for the designated time, measure the DC voltage in the main circuit to ensure the DC voltage is within the safe voltage range. Failure to comply will result in an electric shock.
- Do not perform wiring, remove the equipment cover, or touch the circuit board with power ON. Failure to comply will result in an electric shock.
- Check that the equipment is grounded properly. Failure to comply can result in electric shock.





 WARNING





- Do not connect the input power supply to the output end of the equipment. Failure to comply can result in equipment damage or even a fire.
- When connecting a drive to the motor, check that the phase sequences of the drive and motor terminals are consistent to prevent reverse motor rotation.
- Cables used for wiring must meet cross sectional area and shielding requirements. The shield of the cable must be reliably grounded at one end.
- Fix the terminal screws with the tightening torque specified in the user guide. Improper tightening torque may overheat or damage the connecting part, resulting in a fire.
- After wiring is done, check that all cables are connected properly and no screws, washers or exposed cables are left inside the equipment. Failure to comply may result in an electric shock or equipment damage.

 CAUTION

- Follow the proper electrostatic discharge (ESD) procedure and wear an anti-static wrist strap to perform wiring. Failure to comply may result in damage to the equipment or to the internal circuit of the product.
- Use shielded twisted pairs for the control circuit. Connect the shield to the grounding terminal of the equipment for grounding purpose. Failure to comply will result in equipment malfunction.

### Power-on

 <b>DANGER</b> <ul style="list-style-type: none"><li>• Before power-on, check that the equipment is installed properly with reliable wiring and the motor can be restarted.</li><li>• Check that the power supply meets equipment requirements before power-on to prevent equipment damage or a fire.</li><li>• After power-on, do not open the cabinet door or protective cover of the equipment, touch any terminal, or disassemble any unit or component of the equipment. Failure to comply will result in an electric shock.</li></ul>
 <b>WARNING</b> <ul style="list-style-type: none"><li>• Perform a trial run after wiring and parameter setting to ensure the equipment operates safely. Failure to comply may result in personal injuries or equipment damage.</li><li>• Before power-on, check that the rated voltage of the equipment is consistent with that of the power supply. Failure to comply may result in a fire.</li><li>• Before power-on, check that no one is near the equipment, motor, or machine. Failure to comply may result in death or personal injuries.</li></ul>
<b>Operation</b>
 <b>DANGER</b> <ul style="list-style-type: none"><li>• The equipment must be operated only by professionals. Failure to comply will result in death or personal injuries.</li><li>• Do not touch any connecting terminals or disassemble any unit or component of the equipment during operation. Failure to comply will result in an electric shock.</li></ul>
 <b>WARNING</b> <ul style="list-style-type: none"><li>• Do not touch the equipment casing, fan, or resistor with bare hands to feel the temperature. Failure to comply may result in personal injuries.</li><li>• Prevent metal or other objects from falling into the equipment during operation. Failure to comply may result in a fire or equipment damage.</li></ul>
<b>Maintenance</b>
 <b>DANGER</b> <ul style="list-style-type: none"><li>• Equipment installation, wiring, maintenance, inspection, or parts replacement must be performed only by professionals.</li><li>• Do not maintain the equipment with power ON. Failure to comply will result in an electric shock.</li><li>• Before maintenance, cut off all the power supplies of the equipment and wait for at least the time designated on the equipment warning label.</li><li>• In case of a permanent magnet motor, do not touch the motor terminals immediately after power-off because the motor terminals will generate induced voltage during rotation even after the equipment power supply is off. Failure to comply will result in an electric shock.</li></ul>

 <b>WARNING</b> <ul style="list-style-type: none"> <li>• Perform routine and periodic inspection and maintenance on the equipment according to maintenance requirements and keep a maintenance record.</li> </ul>
<b>Repair</b>
 <b>DANGER</b> <ul style="list-style-type: none"> <li>• Equipment installation, wiring, maintenance, inspection, or parts replacement must be performed only by professionals.</li> <li>• Do not repair the equipment with power ON. Failure to comply will result in an electric shock.</li> <li>• Before inspection and repair, cut off all the power supplies of the equipment and wait for at least the time designated on the equipment warning label.</li> </ul>
 <b>WARNING</b> <ul style="list-style-type: none"> <li>• Submit the repair request according to the warranty agreement.</li> <li>• When the fuse is blown or the circuit breaker or earth leakage current breaker (ELCB) trips, wait for at least the time designated on the equipment warning label before power-on or further operations. Failure to comply may result in death, personal injuries or equipment damage.</li> <li>• When the equipment is faulty or damaged, the troubleshooting and repair work must be performed by professionals that follow the repair instructions, with repair records kept properly.</li> <li>• Replace quick-wear parts of the equipment according to the replacement instructions.</li> <li>• Do not use damaged equipment. Failure to comply may result in death, personal injuries, or severe equipment damage.</li> <li>• After the equipment is replaced, check the wiring and set parameters again.</li> </ul>
<b>Disposal</b>
 <b>WARNING</b> <ul style="list-style-type: none"> <li>• Dispose of retired equipment in accordance with local regulations and standards. Failure to comply may result in property damage, personal injuries, or even death.</li> <li>• Recycle retired equipment by observing industry waste disposal standards to avoid environmental pollution.</li> </ul>

## Safety label

For safe equipment operation and maintenance, comply with the safety labels on the equipment. Do not damage or remove the safety labels. The following table describes the meaning of the safety labels.

Safety label	Description
	<ul style="list-style-type: none"><li>• Read through the safety instructions before operating the equipment. Failure to comply may result in death, personal injuries, or equipment damage.</li><li>• Do not touch the terminals or remove the cover with power ON or within 10 min after power-off. Failure to comply will result in an electric shock.</li></ul>

# 1 Product Information

## 1.1 Product Positioning and Characteristics

The MD580 series AC drive is a low-voltage high-performance engineering AC drive used to control three-phase AC permanent magnet synchronous motors and asynchronous motors.



Figure 1-1 Product appearance

The AC drive has the following features:

- Provides excellent dynamic characteristics and superior overload capacity in driving three-phase AC asynchronous motors and permanent magnet synchronous motors.
- Adopts high-performance vector control technology that enables low-speed high-torque output.
- Provides user-programmable functions, background software monitoring, and communication bus functions, supporting multiple types of encoders and featuring powerful functionality and stable performance.

## 1.2 Nameplate and Model

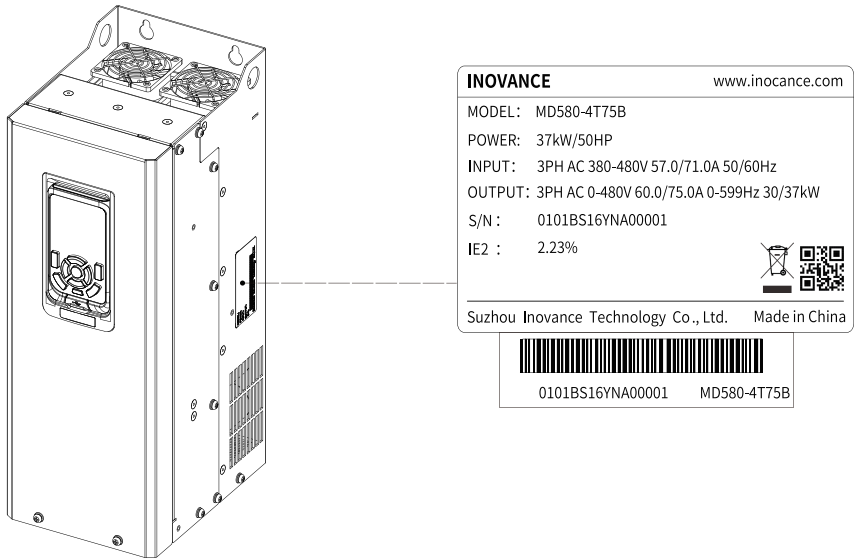

Figure 1-2 Nameplate and naming rules

MD580-4T
75
B

①
②
③
④
⑤

① <b>Product name</b> MD580 series AC drive	③ <b>Output current (A)</b> 2R1: 2.1 ...: ... 820: 820	⑤ <b>AC output reactor</b> Null: without the AC output reactor -L: with the AC output reactor; applicable to the T10 to T12 models
② <b>Voltage class</b> 4T: three-phase 380 V to 480 V	④ <b>Braking unit</b> Null: without the braking unit B: with the braking unit	

### Note

- For three-phase 380 V to 480 V AC drives, reactors are not available for T1 to T4 models, whereas DC reactors are standard for T5 models and above.
- For three-phase 380 V to 480 V AC drives, braking units are standard for T1 to T4 models and optional for T5 to T8 models.
- The output current refers to the rated output current for light overload (P-type AC drive).
- Mark "L" indicates that the AC drive has a base for installing an AC output reactor.

## 1.3 Technical Data

### 1.3.1 Electrical Specifications

The rated power of AC drives in the following tables is measured on three-phase 380 V to 480 V models at the input voltage of 400 VAC.

AC drive application modes are classified into the light load mode (P-type AC drives) and heavy load mode (G-type AC drives).

- The light load mode is represented by the uppercase letter "P". P-type AC drives comply with requirements of rated power, rated input current, rated output current, and overload curve in this mode.
- The heavy load mode is represented by the uppercase letter "G". G-type AC drives comply with requirements of rated power, rated input current, rated output current, and overload curve in this mode.
- To facilitate distinction, P-type AC drive parameters are suffixed with "P" and G-type AC drive parameters are suffixed with "G". Data in this guide is from P-type AC drives unless otherwise specified.

### Three-phase 380 V to 480 V

Table 1–1 Electrical specifications (three-phase 380 V to 480 V) (T1 models)

Item		Specifications					
Model: MD580-4Txxxx		2R1B	3R1B	3R8B	5R1B	7R2B	9B
Structure		T1					
Output	Power (kW)	0.75P/0.4G	1.1P/0.75G	1.5P/1.1G	2.2P/1.5G	3P/2.2G	3.7P/3G
	Rated output current (A)	2.1P/1.5G	3.1P/2.1G	3.8P/3.1G	5.1P/3.8G	7.2P/5.1G	9P/7.2G
	Output voltage	Three-phase 0 V to input voltage					
	Max. output frequency	599 Hz (editable through parameter setting)					
	Carrier frequency	0.8 kHz to 12.0 kHz (automatically adjusted based on load characteristics)					
	Overload capacity	P-type AC drive: 110% rated current for 60s; G-type AC drive: 150% rated current for 60s					
Input	Rated input current (A)	2.5P/1.8G	3.7P/2.4G	4.6P/3.7G	6.4P/4.6G	9.1P/6.3G	11.3P/9G
	Rated voltage/frequency	Three-phase 380 VAC to 480 VAC, 50/60 Hz					
	Voltage range	Allowed fluctuation: -15% to +10%; actual allowed range: 323 VAC to 528 VAC					
	Frequency range	Allowed fluctuation: ±5%; actual allowed range: 47.5 Hz to 63 Hz					
	Power capacity (kVA)	2	2.8	4.1	5	6.7	9.5

Item		Specifications					
Model: MD580-4Txxxx		2R1B	3R1B	3R8B	5R1B	7R2B	9B
Heat dissipation	Thermal design power (kW)	0.039	0.046	0.057	0.068	0.081	0.109
	Air flow (CFM)	9	9	9	9	9	9
Overvoltage class		OVC III					
Pollution degree		PD2					
IP rating		IP20 (open type, for IEC products)					

Table 1-2 Electrical specifications (three-phase 380 V to 480 V) (T2 to T4 models)

Item		Specifications				
Model: MD580-4Txxxx		13B	17B	25B	32B	37B
Structure		T2		T3		T4
Output	Power (kW)	5.5P/3.7G	7.5P/5.5G	11P/7.5G	15P/11G	18.5P/15G
	Rated output current (A)	13P/9G	17P/13G	25P/17G	32P/25G	37P/32G
	Output voltage	Three-phase 0 V to input voltage				
	Max. output frequency	599 Hz (editable through parameter setting)				
	Carrier frequency	0.8 kHz to 12.0 kHz (automatically adjusted based on load characteristics)				
	Overload capacity	P-type AC drive: 110% rated current for 60s; G-type AC drive: 150% rated current for 60s				
Input	Rated input current (A)	15.9P/11.4G	22.4P/16.7G	32.9P/21.9G	39.7P/32.2G	48.6P/41.3G
	Rated voltage/frequency	Three-phase 380 VAC to 480 VAC, 50/60 Hz				
	Voltage range	Allowed fluctuation: -15% to +10%; actual allowed range: 323 VAC to 528 VAC				
	Frequency range	Allowed fluctuation: ±5%; actual allowed range: 47.5 Hz to 63 Hz				
	Power capacity (kVA)	12	17.5	22.8	33.4	42.8
Heat dissipation	Thermal design power (kW)	0.138	0.201	0.24	0.355	0.454
	Air flow (CFM)	20	24	30	40	42
Overvoltage class		OVC III				
Pollution degree		PD2				
IP rating		IP20 (open type, for IEC products)				

Table 1–3 Electrical specifications (three-phase 380 V to 480 V) (T5 to T6 models)

Item		Specifications					
Model: MD580-4Txxxx		45(B)		60(B)		75(B)	91(B)
Structure		T5			T6		
Output	Power (kW)	22P/18.5G		30P/22G		37P/30G	45P/37G
	Rated output current (A)	45P/37G		60P/45G		75P/60G	91P/75G
	Output voltage	Three-phase 0 V to input voltage					
	Max. output frequency	599 Hz (editable through parameter setting)					
	Carrier frequency	0.8 kHz to 12.0 kHz (automatically adjusted based on load characteristics)					
	Overload capacity	P-type AC drive: 110% rated current for 60s; G-type AC drive: 150% rated current for 60s					
Input	Rated input current (A)	59P/49.5G		65.8P/59G		71P/57G	86P/69G
	Rated voltage/frequency	Three-phase 380 VAC to 480 VAC, 50/60 Hz					
	Voltage range	Allowed fluctuation: -15% to +10%; actual allowed range: 323 VAC to 528 VAC					
	Frequency range	Allowed fluctuation: ±5%; actual allowed range: 47.5 Hz to 63 Hz					
	Power capacity (kVA)	45	54	45	54	52	63
Heat dissipation	Thermal design power (kW)	0.478	0.551	0.478	0.551	0.694	0.815
	Air flow (CFM)	51.9	57.4	51.9	57.4	118.5	118.5
Overvoltage class		OVC III					
Pollution degree		PD2					
IP rating		IP20 (open type, for IEC products)					

Table 1–4 Electrical specifications (three-phase 380 V to 480 V) (T7 to T9 models)

Item		Specifications						
Model: MD580-4Txxxx		112(B)	150B	176B	210	253	304	377
Structure		T7			T8		T9	
Output	Power (kW)	55P/45G	75P/55G	90P/75G	110P/90G	132P/110G	160P/132G	200P/160G
	Rated output current (A)	112P/91G	150P/112G	176P/150G	210P/176G	253P/210G	304P/253G	377P/304G
	Output voltage	Three-phase 0 V to input voltage						
	Max. output frequency	599 Hz (editable through parameter setting)						
	Carrier frequency	0.8 kHz to 12.0 kHz (automatically adjusted based on load characteristics)			0.8 kHz to 6.0 kHz (automatically adjusted based on load characteristics)			
	Overload capacity	P-type AC drive: 110% rated current for 60s; G-type AC drive: 150% rated current for 60s						

Item		Specifications						
Model: MD580-4Txxxx		112(B)	150B	176B	210	253	304	377
Input	Rated input current (A)	111P/89G	143P/106G	167P/139G	198P/164G	239P/196G	295P/240G	359P/287G
	Rated voltage/frequency	Three-phase 380 VAC to 480 VAC, 50/60 Hz						
	Voltage range	Allowed fluctuation: -15% to +10%; actual allowed range: 323 VAC to 528 VAC						
	Frequency range	Allowed fluctuation: ±5%; actual allowed range: 47.5 Hz to 63 Hz						
	Power capacity (kVA)	81	97	127	150	179	220	263
Heat dissipation	Thermal design power (kW)	1.01	1.21	1.57	1.81	2.14	2.85	3.56
	Air flow (CFM)	122.2	122.2	218.6	287.2	354.2	547	627
Overvoltage class		OVC III						
Pollution degree		PD2						
IP rating		IP20 (open type, for IEC products)						

Table 1-5 Electrical specifications (three-phase 380 V to 480 V) (T10 to T11 models)

Item		Specifications			
Model: MD580-4Txxxx		426	465	520	585
Structure		T10		T11	
Output	Power (kW)	220P/200G		250P/220G	
	Rated output current (A)	426P/377G		465P/426G	
	Output voltage	Three-phase 0 V to input voltage			
	Max. output frequency	599 Hz (editable through parameter setting)			
	Carrier frequency	0.8 kHz to 6.0 kHz (automatically adjusted based on load characteristics)			
	Overload capacity	P-type AC drive: 110% rated current for 60s; G-type AC drive: 150% rated current for 60s			
Input	Rated input current (A)	410P/365G		456P/410G	
	Rated voltage/frequency	Three-phase 380 VAC to 480 VAC, 50/60 Hz			
	Voltage range	Allowed fluctuation: -15% to +10%; actual allowed range: 323 VAC to 528 VAC			
	Frequency range	Allowed fluctuation: ±5%; actual allowed range: 47.5 Hz to 63 Hz			
	Power capacity (kVA)	334	375	404	453
Heat dissipation	Thermal design power (kW)	4.15	4.55	5.06	5.33
	Air flow (CFM)	638.4	722.5	789.4	882
Overvoltage class		OVC III			
Pollution degree		PD2			
IP rating		IP20 (open type, for IEC products)			

Table 1-6 Electrical specifications (three-phase 380 V to 480 V) (T12 models)

Item		Specifications		
Model: MD580-4Txxxx		650	725	820
Structure		T12		
Output	Power (kW)	355P/315G	400P/355G	450P/400G
	Rated output current (A)	650P/585G	725P/650G	820P/725G
	Output voltage	Three-phase 0 V to input voltage		
	Max. output frequency	599 Hz (editable through parameter setting)		
	Carrier frequency	0.8 kHz to 6.0 kHz (automatically adjusted based on load characteristics)		
	Overload capacity	P-type AC drive: 110% rated current for 60s; G-type AC drive: 150% rated current for 60s		
Input	Rated input current (A)	624P/565G	708P/617G	782P/687G
	Rated voltage/frequency	Three-phase 380 VAC to 480 VAC, 50/60 Hz		
	Voltage range	Allowed fluctuation: -15% to +10%; actual allowed range: 323 VAC to 528 VAC		
	Frequency range	Allowed fluctuation: $\pm 5\%$ ; actual allowed range: 47.5 Hz to 63 Hz		
	Power capacity (kVA)	517	565	629
Heat dissipation	Thermal design power (kW)	5.69	6.31	6.91
	Air flow (CFM)	645	860	860
Overvoltage class		OVC III		
Pollution degree		PD2		
IP rating		IP20 (open type, for IEC products)		

### 1.3.2 Technical Specifications

Table 1–7 Technical specifications of the AC drive

Item		Technical Specifications
Standard functions	Input frequency resolution	Digital setting: 0.01 Hz Analog setting: maximum frequency x 0.025%
	Control mode	Sensorless vector control (SVC), feedback vector control (FVC), and voltage/frequency (V/f) control
	Starting torque	0.25 Hz/150% (SVC); 0 Hz/180% (FVC)
	Speed range	1:200 (SVC) 1:1000 (FVC)
	Speed stability accuracy	±0.5% (SVC) ±0.02% (FVC)
	Torque control accuracy	±3% (FVC) ±5% above 5 Hz (SVC)
	Torque boost	Automatic torque boost Customized torque boost: 0.1% to 30.0%
	V/f curve	Straight-line V/f; multi-point V/f; square V/f; N-power V/f (N = 1.2/1.4/1.6/1.8); V/f separation
	Acceleration/Deceleration curve	Straight-line or S-curve acceleration/deceleration Four modes of acceleration/deceleration time ranging from 0.0s to 1000.0s
	DC injection braking	DC injection braking current at startup: 0.0% to 100.0% DC injection braking time at startup: 0.00s to 100.00s Start speed of DC injection braking at stop: 0.0 RPM to 6000.0 RPM DC injection braking current at stop: 0.0% to 100.0% DC injection braking time at stop: 0.00s to 100.00s
	Jog control	Jog frequency range: –600.0% to +600.0% Jog acceleration/deceleration time: 0.0s to 1000.0s
	Multi-speed running	The system implements up to 16 speeds by using the control terminals.
	Built-in PID	The system implements the Proportional-Integral-Derivative (PID) function in the closed-loop control.
	Overvoltage/Overcurrent stall control	The system limits the current and voltage automatically during operation to avoid frequent tripping due to overvoltage/overcurrent.
	Quick current limit	This function minimizes the occurrence of overcurrent faults and guarantees proper operation of the drive.
Torque limit and control	This function limits the torque during running to avoid frequent tripping due to overcurrent and realizes torque control in vector control mode.	

Item		Technical Specifications
Customized functions	VDC voltage control	Load feedback energy compensates for any voltage reduction, allowing the drive to continue to operate for a short time.
	Multi-thread buses	Five field buses: Modbus RTU, CANopen, PROFIBUS-DP, PROFINET I/O, and Modbus TCP
	Multiple encoder types	Differential encoder, open-collector encoder, and resolver
	Advanced software tool	Software of the AC drive allows users to configure operating parameters and provides a virtual oscilloscope display that shows system status.
	Motor overtemperature protection	Inputs from motor temperature sensors (PT100, PT1000, KTY-84, and PTC-130) are supported.
Running	Two control channels and two reference setting channels, separately selectable	
Display and operation on the operating panel	LED display	The LED shows parameters.
	LCD display	Optional and two languages (Chinese and English) supported
	Parameter copy	Quick parameter copy through the optional LCD
Protection functions	Phase loss protection	Input/output phase loss protection
	Instantaneous overcurrent protection	The AC drive stops when the output current exceeds 250% of the rated output current.
	Overvoltage protection	The AC drive stops when the DC voltage of the main circuit is above 820 V.
	Undervoltage protection	The AC drive stops when the DC voltage of the main circuit is below 350 V.
	Overtemperature protection	Protection triggered in case of inverter bridge overtemperature
	Overload protection	The P-type AC drive stops after running at 110% of rated current for 60s. The G-type AC drive stops after running at 150% of rated current for 60s.
	Overcurrent protection	The AC drive stops when the current exceeds 2.5 times the rated current.
	Braking protection	Braking unit overload protection Braking resistor short-circuit protection
	Short circuit protection	Output phase-to-phase short circuit protection Output phase-to-ground short circuit protection

Item		Technical Specifications
Environment	Operating location	Indoors without direct sunlight, dust, corrosive gas, combustible gas, oil mist, water vapor, drip, or salt
	Altitude	1000 m and below: no derating Above 1000 m: Derate 1% for every additional 100 m. Above 3000 m: Contact Inovance. (Note: The maximum altitude for T1 models is 2000 m. For altitude above 2000 m, contact Inovance.)
	Ambient temperature	-10°C to +50°C. For temperature between 40°C to 50°C, derate 1.5% for every additional 1°C.
	Humidity	Less than 95% RH, non-condensing
	Vibration	Less than 5.9 m/s <sup>2</sup> (0.6 g)
	Storage temperature	-20°C to +60°C

## 1.4 Components

### 1.4.1 Overview

AC drives of the T1 to T12 models use the sheet metal structure.

## 1.4.2 Components of T1 to T6 Models

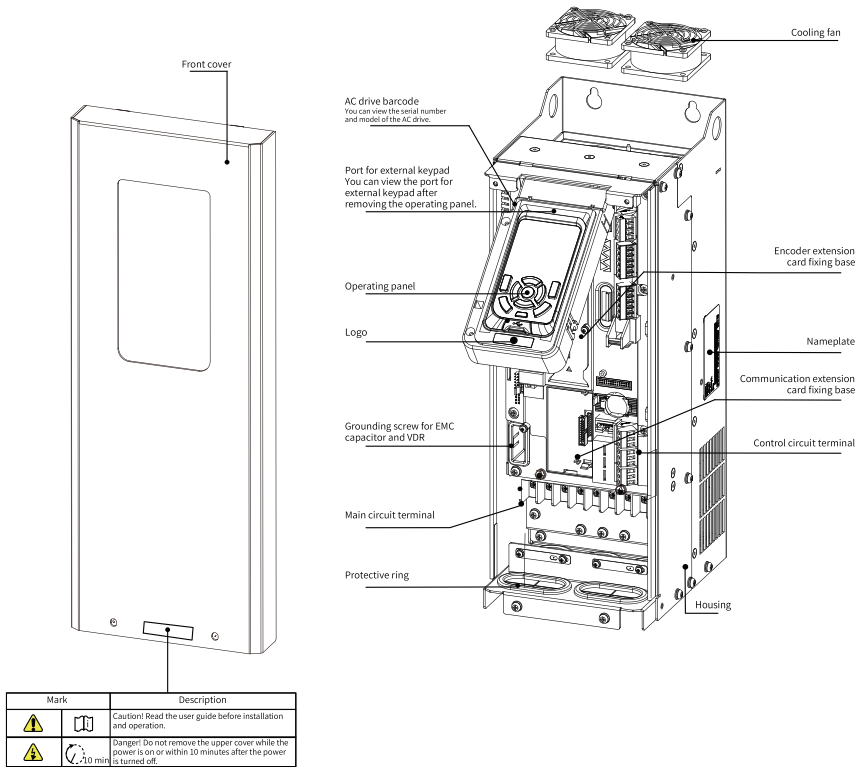

Figure 1-3 Components of T1 to T6 models

### 1.4.3 Components of T7 to T9 Models

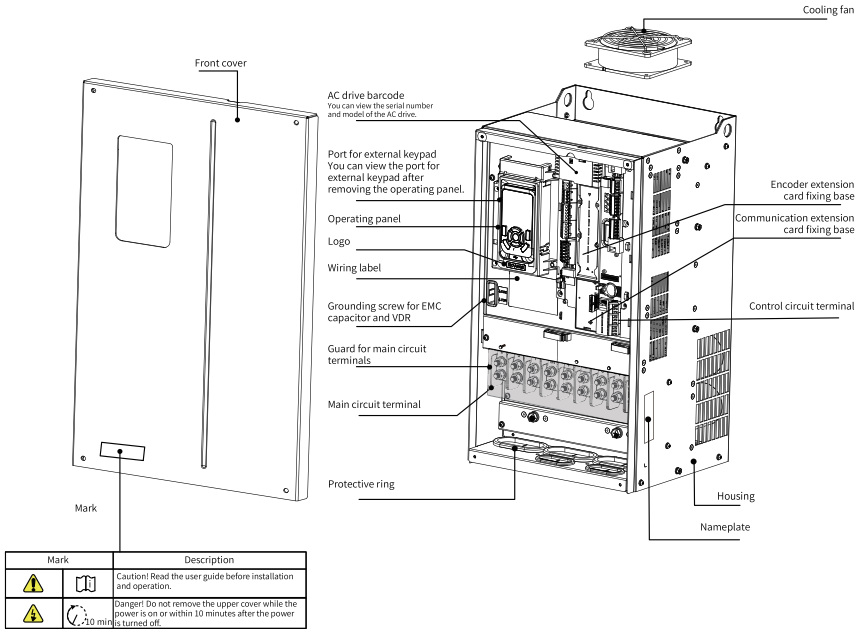

Figure 1-4 Components of T7 to T9 models

### Note

The quantity and layout of cooling fans vary with models.

- T7 models have one cooling fan at the top.
- T8 models have two cooling fans at the top.
- T9 models have two cooling fans at the bottom.

### 1.4.4 Components of T10 to T12 Models

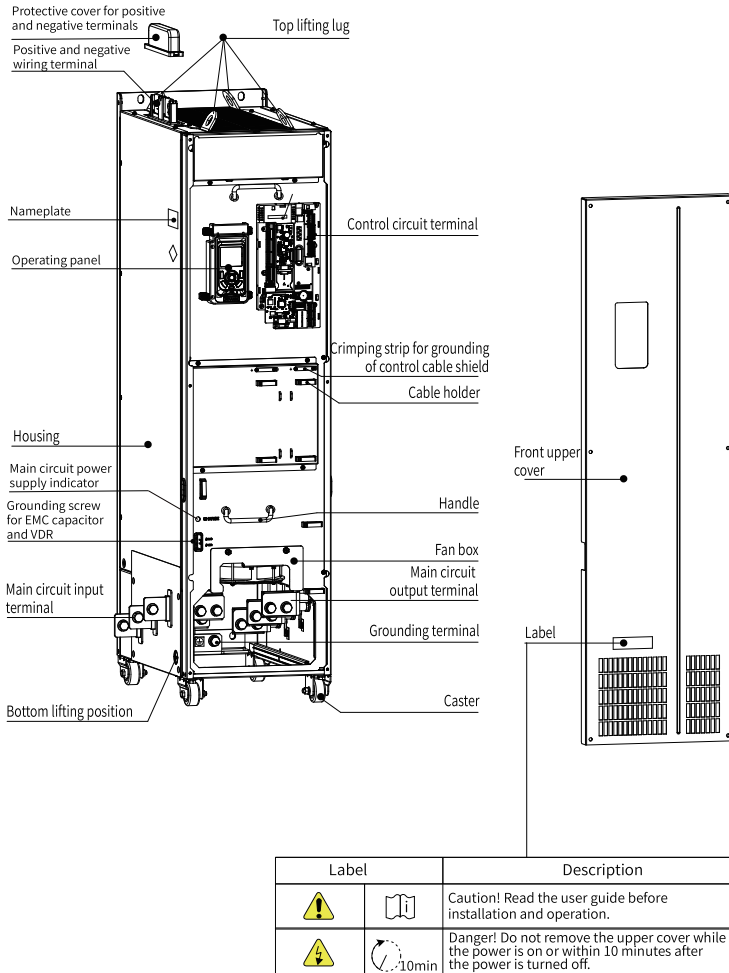
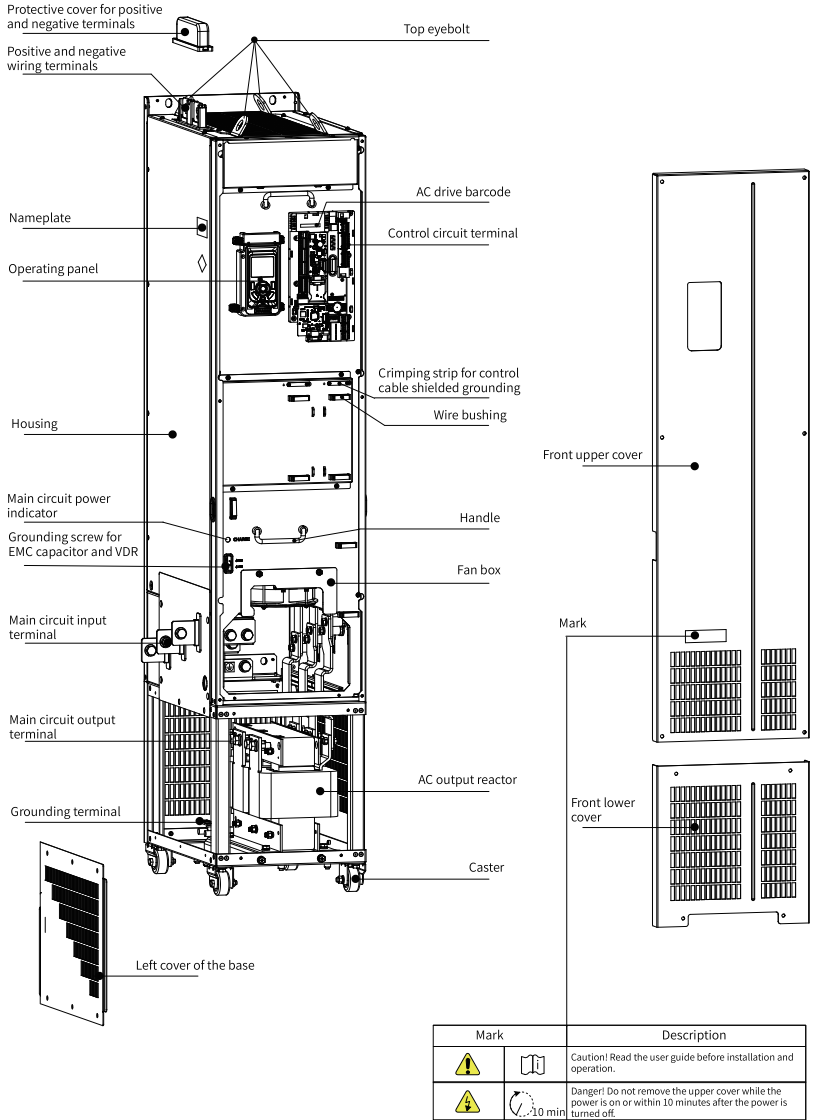

Figure 1-5 Components of T10 to T12 models (without an AC output reactor)



Mark	Description
	Caution! Read the user guide before installation and operation.
	Danger! Do not remove the upper cover while the power is on or within 10 minutes after the power is turned off.

Figure 1-6 Components of T10 to T12 models (with an AC output reactor)

## 2 Mechanical Design

### 2.1 AC Drive Dimensions

#### 2.1.1 T1 to T9 Models

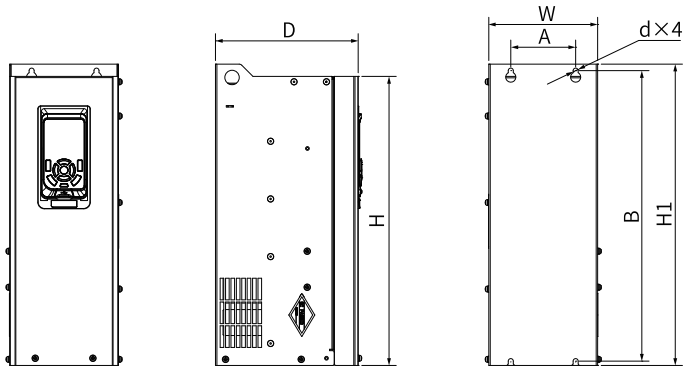

Figure 2-1 Installation dimensions of T1 to T6 models

Table 2-1 Dimensions of T1 to T6 models

Structure	Mounting Hole Spacing mm (in.)		Outline Dimensions mm (in.)				Mounting Hole Diameter mm (in.)	Weight kg (lb)
	A	B	H	H1	W	D		
T1	90 (3.5)	380 (15.0)	381 (15.0)	395 (15.6)	151 (5.9)	175 (6.9)	Ø7 (0.3)	6.2 (13.6)
T2	90 (3.5)	380 (15.0)	381 (15.0)	395 (15.6)	151 (5.9)	181.5 (7.2)	Ø7 (0.3)	7 (15.4)
T3	90 (3.5)	403 (15.9)	404 (15.9)	418 (16.5)	151 (5.9)	198 (7.8)	Ø7 (0.3)	8.2 (18.0)
T4	120 (4.7)	427 (16.8)	427 (16.8)	442 (17.4)	185 (7.3)	203 (8.0)	Ø7 (0.3)	9.9 (21.8)
T5	170 (6.7)	468.5 (18.5)	460 (18.1)	486 (19.1)	210 (8.3)	224 (8.8)	Ø7 (0.3)	14.9 (32.8)
T6	200 (7.9)	438 (17.3)	429 (16.9)	455 (17.9)	250 (9.9)	252.5 (9.9)	Ø7 (0.3)	23.7 (51.9)

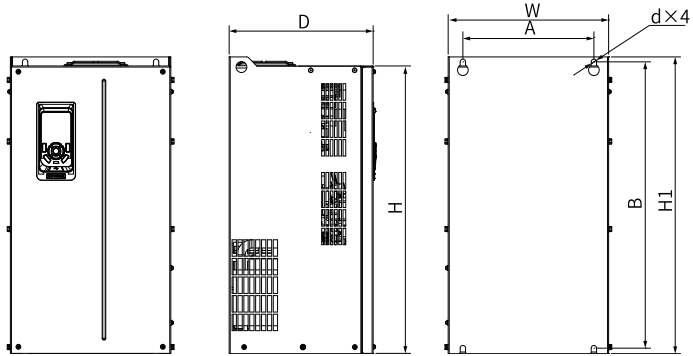

Figure 2-2 Installation dimensions of T7 to T9 models

Table 2-2 Dimensions of T7 to T9 models

Structure	Mounting Hole Spacing mm (in.)		Outline Dimensions mm (in.)				Mounting Hole Diameter mm (in.)	Weight kg (lb)
	A	B	H	H1	W	D		
T7	245 (9.7)	523 (20.6)	525 (20.7)	542 (21.4)	300 (11.8)	269 (10.6)	Ø10 (0.4)	35 (77.2)
T8	270 (10.6)	560 (22.1)	554 (21.8)	580 (22.9)	338 (13.3)	309.4 (12.2)	Ø10 (0.4)	51.5 (113.5)
T9	320 (12.6)	890 (35.1)	874 (34.4)	915 (36.1)	400 (15.8)	314.6 (12.4)	Ø10 (0.4)	85 (187.4)

### 2.1.2 T10 to T12 Models (Without AC Output Reactor)

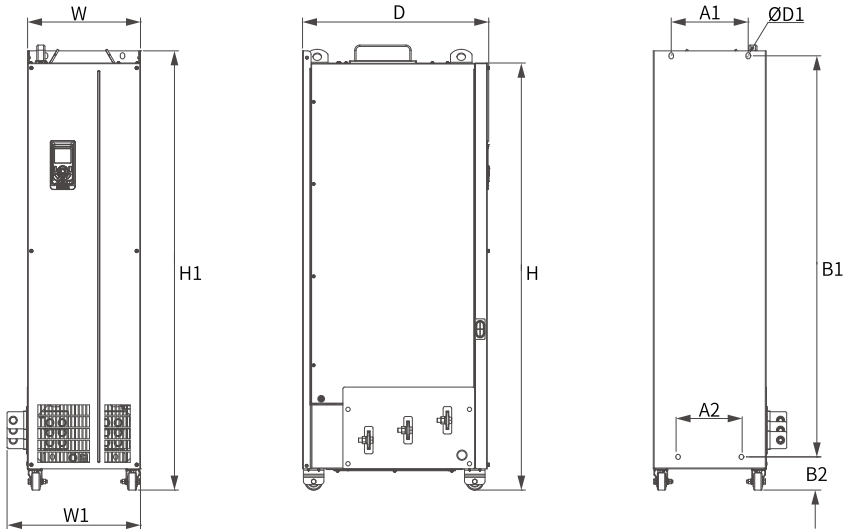

Figure 2-3 Outline dimensions and mounting dimensions of T10 to T12 models (without AC output reactor)

Table 2-3 Outline dimensions and mounting dimensions of T10 to T12 models (without AC output reactor)

Structure	Mounting Hole mm (in.)				Outline Dimensions mm (in.)					Mounting Hole Diameter mm (in.)	Weight kg (lb)
	A1	A2	B1	B2	H	H1	W	W1	D		
T10	240 (9.5)	150 (5.9)	1035 (40.8)	86 (3.4)	1086 (42.8)	1134 (44.7)	300 (11.8)	360 (14.2)	500 (19.7)	Φ13(0.5)	110 (242.5)
T11	225 (8.9)	185 (7.3)	1175 (46.3)	97 (3.8)	1248 (49.2)	1284 (50.6)	330 (13.0)	390 (15.4)	545 (21.5)	Φ13(0.5)	155 (341.7)
T12	240 (9.5)	200 (7.9)	1280 (50.4)	101 (4.0)	1355 (53.4)	1405 (55.4)	340 (13.4)	400 (15.8)	545 (21.5)	Φ16(0.6)	185 (407.9)

### 2.1.3 T10 to T12 Models (with AC Output Reactor)

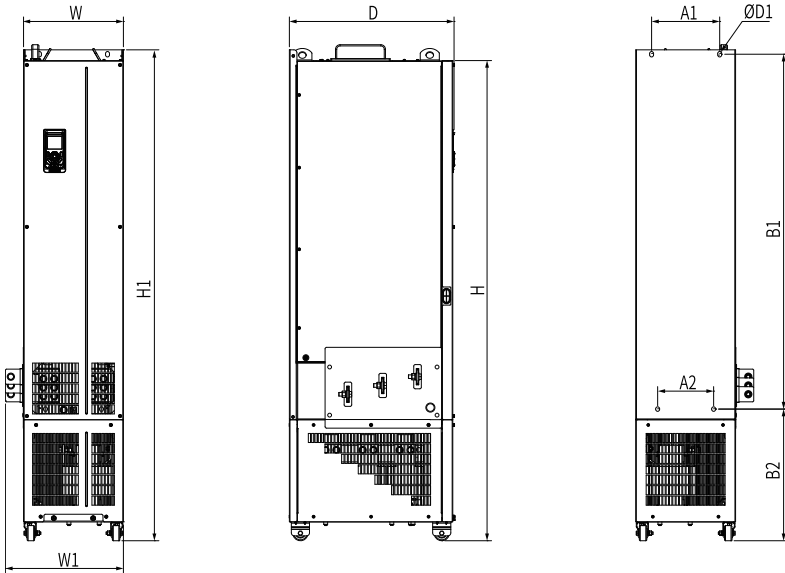

Figure 2-4 Installation dimensions of T10 to T12 models (with AC output reactor)

Table 2-4 Installation dimensions of T10 to T12 models (with AC output reactor)

Structure	Mounting Hole Spacing mm (in.)				Outline Dimensions mm (in.)					Mounting Hole Diameter mm (in.)	Weight kg (lb)
	A1	A2	B1	B2	H	H1	W	W1	D		
T10	240 (9.5)	150 (5.9)	1035 (40.8)	424 (16.7)	1424 (56.1)	1472 (58.0)	300 (11.8)	360 (14.2)	500 (19.7)	φ13 (0.5)	160 (352.7)
T11	225 (8.9)	185 (7.3)	1175 (46.3)	435 (17.1)	1586 (62.5)	1622 (63.9)	330 (13.0)	390 (15.4)	545 (21.5)	φ13 (0.5)	215 (474.0)
T12	240 (9.5)	200 (7.9)	1280 (50.4)	432 (17.0)	1683 (66.3)	1733 (68.3)	340 (13.4)	400 (15.8)	545 (21.5)	φ16 (0.6)	245 (540.1)

## 2.2 Installation Precautions

### T1 to T9 models

Before installation, ensure that the place of installation is mechanically strong enough to bear the AC drive.

- Cover the top of the AC drive with cloth or paper during installation to prevent foreign objects, such as metal chippings, oil, and water, from entering the AC drive. Foreign objects may cause malfunction of the AC drive. Remove the cloth or paper after installation is completed. Failure to comply may degrade ventilation and result in overtemperature of the AC drive.
- Reserve sufficient clearance for heat dissipation, including heat dissipation of other equipment in the cabinet. For details, see "Installing one alone" in Clearance of the MD580 Series Low-Voltage High-Performance Engineering AC Drive Installation Guide.
- Keep the AC drive upright to facilitate upward heat dissipation. To install multiple AC drives in one cabinet, arrange them side by side. Where up and down arrangement is required, install an air guide plate in between. For details, see "Installing one above another" in Clearance of the MD580 Series Low-Voltage High-Performance Engineering AC Drive Installation Guide.
- Use a mounting bracket (if needed) that is flame retardant.
- In environments with metal dust, use an enclosed cabinet that can completely isolate the AC drive from the metal dust. In this case, ensure the maximum possible space in the cabinet and install cooling devices outside the cabinet.

### **T10 to T12 models**

- Before installing the AC drive, install the bottom mounting bracket and guide rails on the cabinet, and prepare fixing beams with mounting holes for retaining the AC drive. Reserve sufficient clearance in the cabinet for connecting side copper busbars.
- The guide rails in the cabinet and the four casters of the AC drive cooperate to help the AC drive move in or out of the cabinet. Align the casters with the guide rails before a push or pull. For safety, arrange two persons to pull or push the AC drive together.
- Reserve sufficient clearance for heat dissipation, including heat dissipation of other equipment in the cabinet.
- To push the AC drive into or pull it out of the cabinet, arrange two persons to work together. After pushing the AC drive into the cabinet, remove the baffle from the air outlet of the cabinet to avoid over-temperature caused by failure to exhaust hot air.
- Install an insulation barrier at the top of the cabinet to prevent the exhaust air from flowing back into the cabinet. Provide an air intake vent on the lower part of the cabinet door.
- The cabinet is 2200 mm x 800 mm x 600 mm (including a ventilation top cover 200 mm in height). The cabinet needs to be installed on a base that is 100 mm in height.

- When installing the AC drive in an enclosed environment, such as a cabinet or casing box, use a cooling fan or air conditioner to keep the inlet temperature below 50°C. Failure to comply may result in overtemperature or fire.
- Cover the top of the AC drive with cloth or paper during installation to prevent foreign objects, such as metal chippings, oil, and water, from entering the AC drive. Foreign objects may cause malfunction of the AC drive. Remove the cloth or paper after installation is completed. Failure to comply may degrade ventilation and result in overtemperature of the AC drive.
- Use a mounting bracket (if needed) that is flame retardant.
- In environments with metal dust, use an enclosed cabinet that can completely isolate the AC drive from the metal dust. In this case, ensure the maximum possible space in the cabinet and install cooling devices outside the cabinet.
- Tighten all screws using the specified torque. Failure to comply may result in electric shock or fire.
- Keep combustible and explosive materials away from the AC drive.

## 2.3 Installation Location

### 2.3.1 Installation Environment

Table 2-5 Environmental requirements

Item	Requirement
Installation location	Indoors
Grid overvoltage	Overvoltage category (OVC): III
Temperature	Installation/Operation: -10°C to +50°C (-10°C to +40°C: no derating; over +40°C: Derate 1.5% for every additional 1°C) Storage/Transportation: -20°C to +60°C <ul style="list-style-type: none"> <li>• For better reliability, use the AC drive in places without sharp temperature changes.</li> <li>• For use in an enclosed space such as a control cabinet, use a cooling fan or air conditioner to keep the temperature of air taken into the AC drive below 50°C. Failure to comply may result in overtemperature or fire.</li> <li>• Install the AC drive on a flame retardant object, with sufficient clearance reserved for heat dissipation.</li> <li>• Avoid freezing of the AC drive.</li> </ul>
Humidity	Below 95% RH (non-condensing)

Item	Requirement
Environment	Pollution degree: 2 or below Install the AC drive in a place: <ul style="list-style-type: none"> <li>• without direct sunlight, dust, corrosive gas, combustible or explosive gas, oil mist, water vapor, drip, and salt.</li> <li>• without vibration, especially vibration caused by equipment such as punch presses.</li> <li>• without foreign objects such as metal powder, oil, and water that may enter the AC drive.</li> <li>• without radioactive materials, combustible materials, hazardous gas and liquid, and salt corrosion.</li> <li>• providing a support made of materials other than combustibles such as timber.</li> </ul>
Altitude	<ul style="list-style-type: none"> <li>• 1000 m and below: no derating.</li> <li>• Above 1000 m: Derate 1% for every additional 100 m.</li> </ul> 0.75 kW to 3.7 kW models: maximum 2000 m. Consult Inovance for use above 2000 m. 3.7kW models and above: maximum 3000 m. Consult Inovance for use above 3000 m.
Vibration resistance	<ul style="list-style-type: none"> <li>• Transportation with packaging: Class 2M3 requirements in EN 60721-3-2</li> <li>• Installation without packaging: compliant with ISTA 1H</li> </ul>

## 2.3.2 Installation Clearance

### T1 to T9 models

- Installing one drive

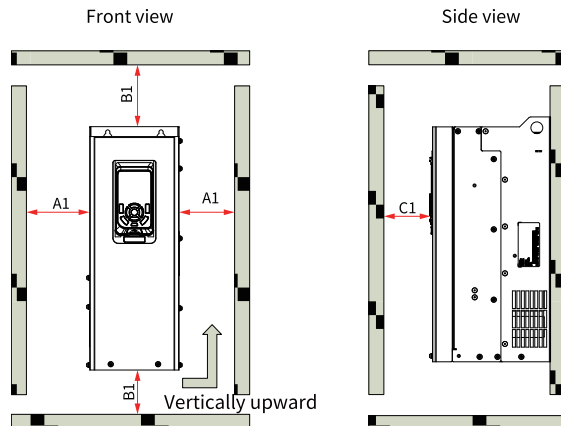

Figure 2-5 Clearance for installing one AC drive (T1 to T9 models)

Table 2-6 Installation clearance

Power Rating	Clearance (mm)		
0.75 kW to 18.5 kW	A1 ≥ 10	B1 ≥ 100	C1 ≥ 40
22 kW to 30 kW	A1 ≥ 10	B1 ≥ 200	C1 ≥ 40
37 kW to 45 kW	A1 ≥ 50	B1 ≥ 200	C1 ≥ 40
55 kW to 200 kW	A1 ≥ 50	B1 ≥ 300	C1 ≥ 40

- Installing multiple drives side by side  
 The AC drive dissipates heat upward. When multiple AC drives are required to work together, install them side by side. Keep their tops level with each other, especially for those of different sizes.

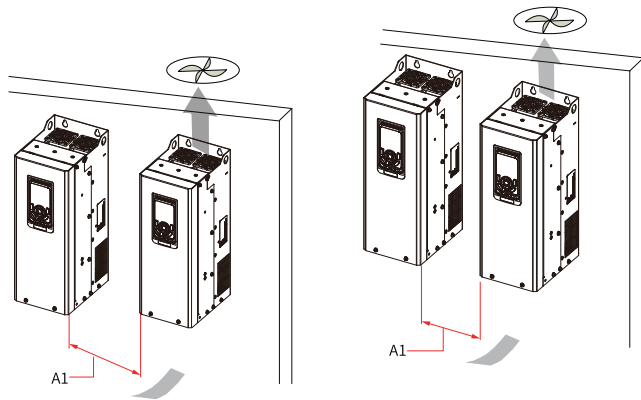

Figure 2-6 Installing multiple AC drives (T1 to T9 models) side by side

Table 2-7 Installation clearance

Power Rating	Clearance (mm)
0.75 kW to 18.5 kW	A1 ≥ 10
22 kW to 30 kW	A1 ≥ 10
37 kW to 45 kW	A1 ≥ 50
55 kW to 200 kW	A1 ≥ 50

- Dual-row installation  
 If one drive needs to be installed above another one, install an air guide plate, as shown in ["Figure 2-7 Installing one above another \(T1 to T9 models\)" on page 37](#). This can prevent the drive in the lower row from heating that in the upper row, causing overheating or overload faults.

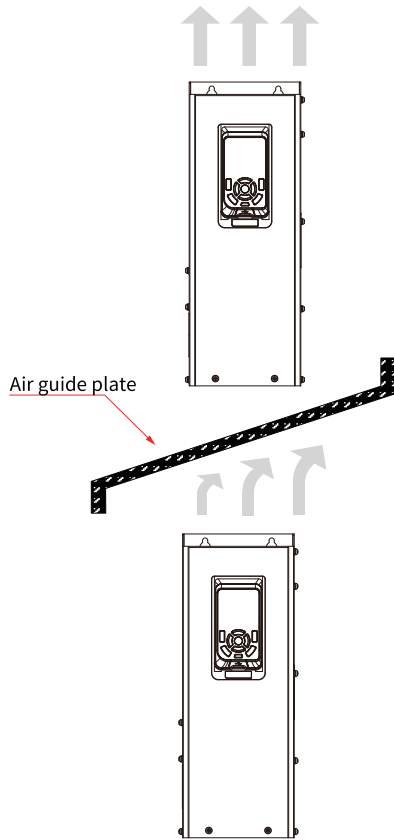

Figure 2-7 Installing one above another (T1 to T9 models)

**T10 to T12 models**

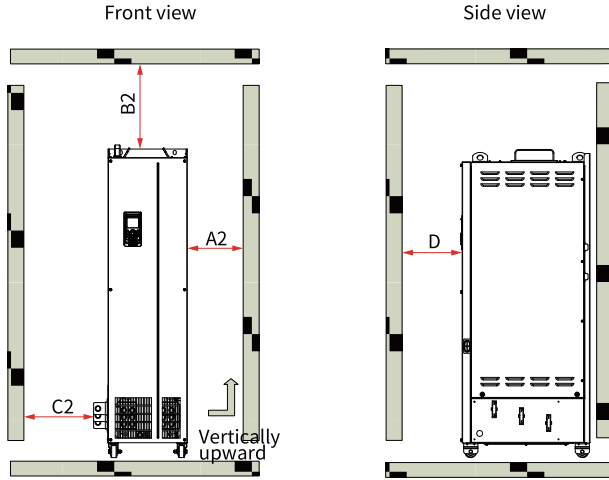

Figure 2-8 Installation clearance (T10 to T12 models)

Table 2-8 Installation clearance

Power Rating	Clearance (mm)			
220 kW to 450 kW	$A2 \geq 10$	$B2 \geq 250$	$C2 \geq 20$	$D2 \geq 20$

**Note**

T10 to T12 models can only be installed individually inside the cabinet. For installation needs, contact Inovance.

**2.4 Heat Dissipation Design**

When installing T10 to T12 models in a cabinet, reserve sufficient space for heat dissipation. A self-ventilated cabinet has no fan on the top.

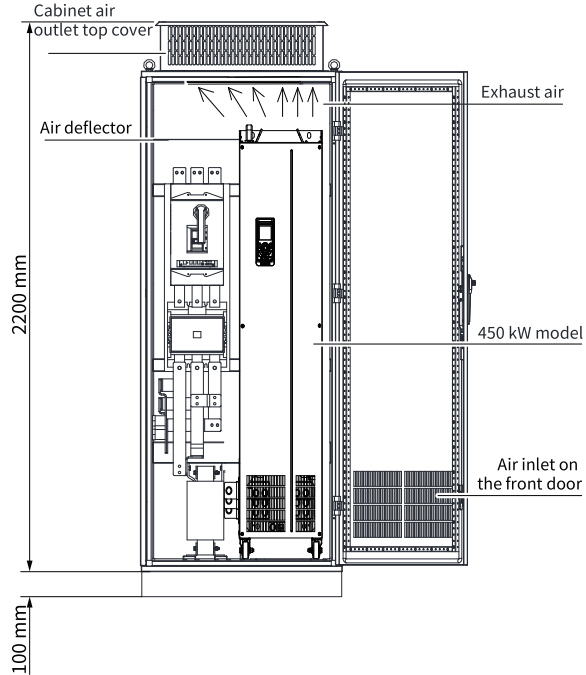

Figure 2-9 Self-ventilated cabinet

Table 2-9 Parameters of a self-ventilated cabinet

Model	Quantity of Fans	Total Air Volume (CFM)	Effective Area of the Cabinet Air Inlet (mm <sup>2</sup> )	Effective Area of the Cabinet Air Outlet (mm <sup>2</sup> )
T10 (220 kW)	2	586	31809	50894
T10 (250 kW)	2	722	31809	50894
T11 (280 kW)	3	789	47713	76341
T11 (315 kW)	3	882	47713	76341
T12 (355 kW)	3	644	47713	76341
T12 (400 kW)	3	796	47713	76341
T12 (450 kW)	3	796	47713	76341

**Note**

- CFM = 0.0283 m<sup>3</sup>/min
- "Actual Effective Area" indicates through-hole area.

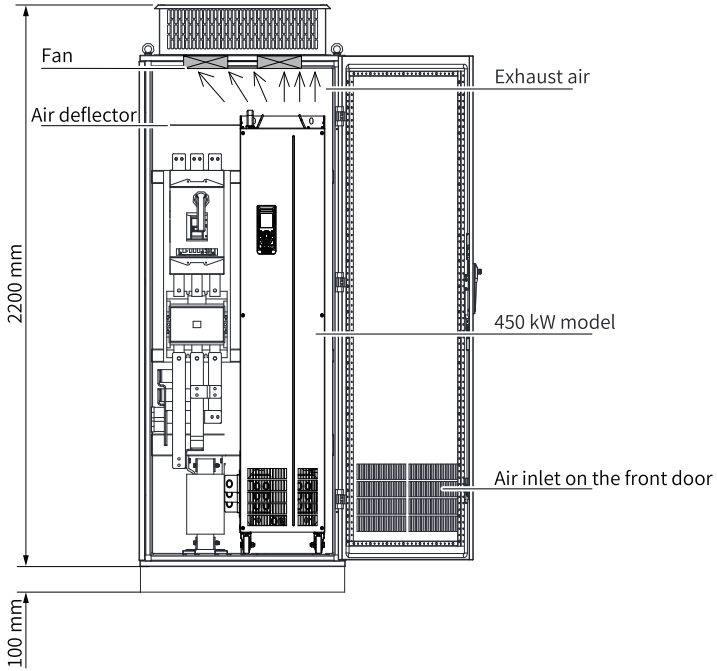

Figure 2-10 Forced-ventilated cabinet (with fans at the top of the cabinet)

Table 2-10 Parameters of a forced-ventilated cabinet

Model	Quantity of Fans	Total Air Volume (CFM)	Effective Area of the Cabinet Air Inlet (mm <sup>2</sup> )	Max. Air Volume Required by the Fans (CFM)	Effective Area of the Cabinet Air Outlet (mm <sup>2</sup> )
T10 (220 kW)	2	586	31809	703	
T10 (250 kW)	2	722	31809	866	
T11 (280 kW)	3	789	47713	947	
T11 (315 kW)	3	882	47713	1058	
T12 (355 kW)	3	644	47713	773	
T12 (400 kW)	3	796	47713	955	
T12 (450 kW)	3	796	47713	955	

**Note**

- CFM = 0.0283 m<sup>3</sup>/min
- "Actual Effective Area" indicates through-hole area.

As shown in the following figure, the heat dissipation duct of the drive must be isolated in the cabinet to prevent the hot air from circulating in the cabinet. Use an air

deflector for isolation to ensure that the hot air of the drive can be exhausted from the heat dissipation hole on the top of the cabinet.

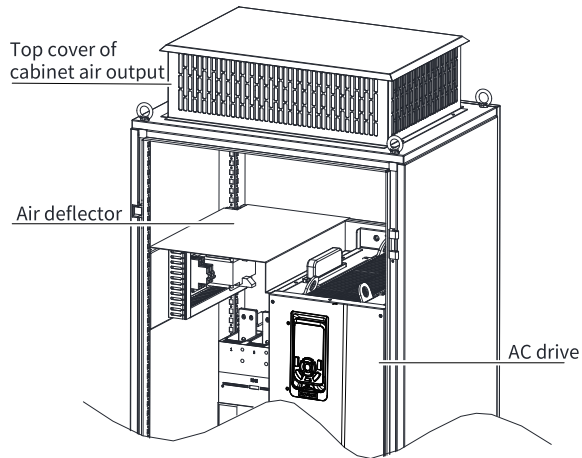

Figure 2-11 Insulation barrier in the cabinet

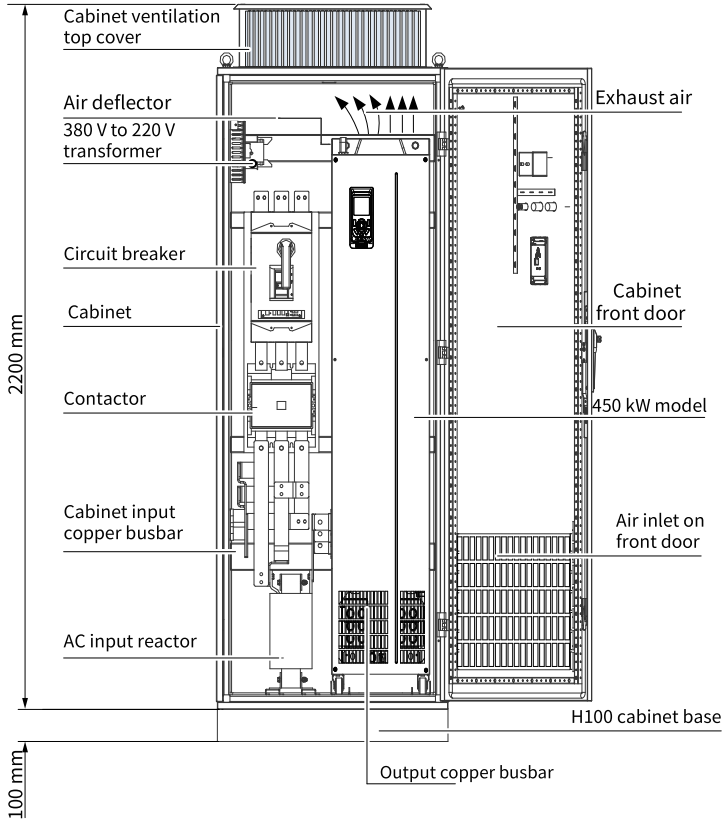

Figure 2-12 Recommended cabinet layout for T12 models

## 2.5 Installation Mode

### 2.5.1 Backplate Mounting

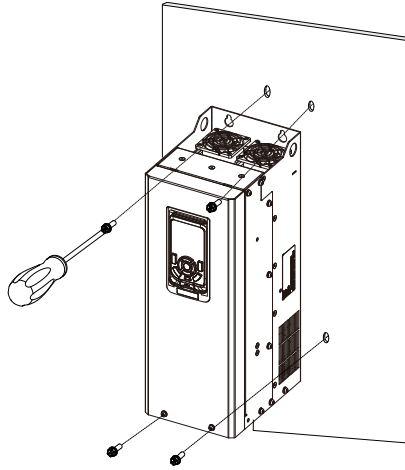

Figure 2-13 Backplate mounting (T1 to T6 models)

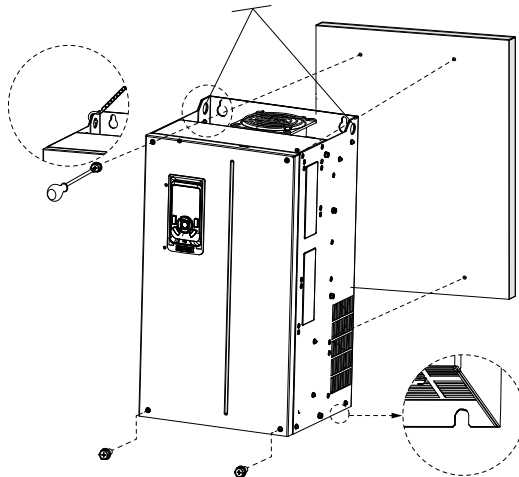

Figure 2-14 Backplate mounting (T7 to T9 models)

## 2.5.2 Through-hole Mounting (T1 to T9)

---

### **Note**

The through-hole mounting bracket is an option.

---

1. Fix the mounting brackets to both sides of the AC drive.

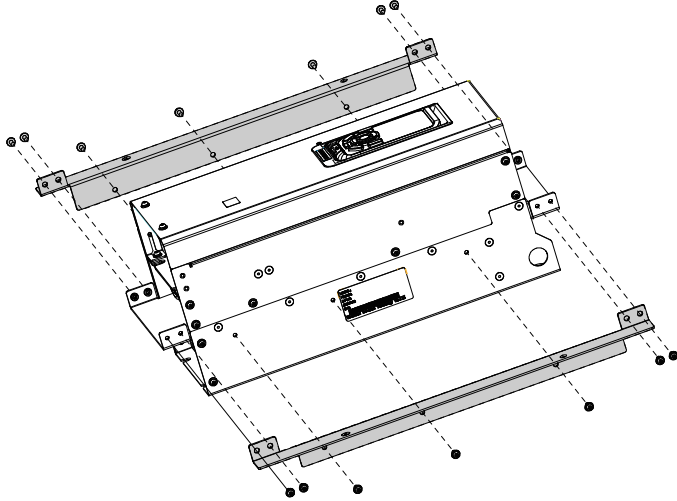

Figure 2-15 Installing the mounting brackets to the AC drive (T1 to T9 models)

2. The following figure shows the AC drive with brackets mounted.

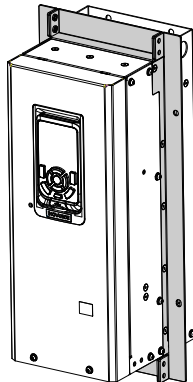

Figure 2-16 AC drive with brackets mounted (T1 to T9 models)

3. Fix the AC drive with the brackets to the back of the control cabinet.

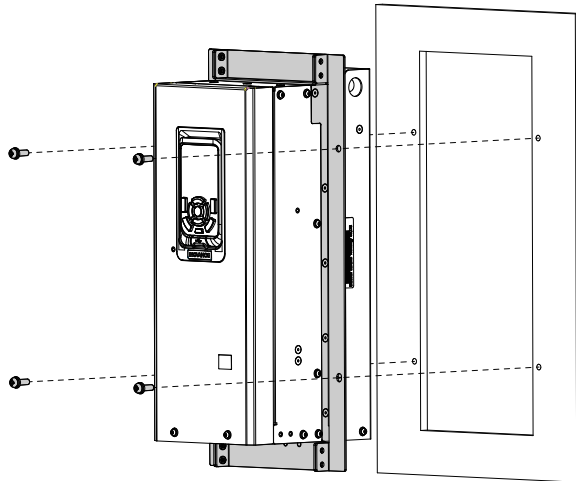

Figure 2-17 Through-hole mounting (T1 to T9 models)

4. The following figure shows the AC drive installed in the cabinet by the through-hole mounting method.

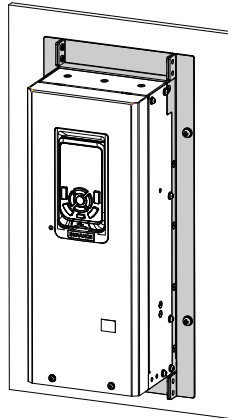

Figure 2-18 AC drive installed in the cabinet (T1 to T9 models)

### 2.5.3 In-Cabinet Installation (T10 to T12)

#### Procedure

1. In the nine-fold profile cabinet (PS cabinet), install the mounting beam for fixing the AC drive and reserve fixed holes.

*"Figure 2-19 Top view of a cabinet for T10 and T12 models" on page 46* shows the cross sectional area of the nine-fold profile.

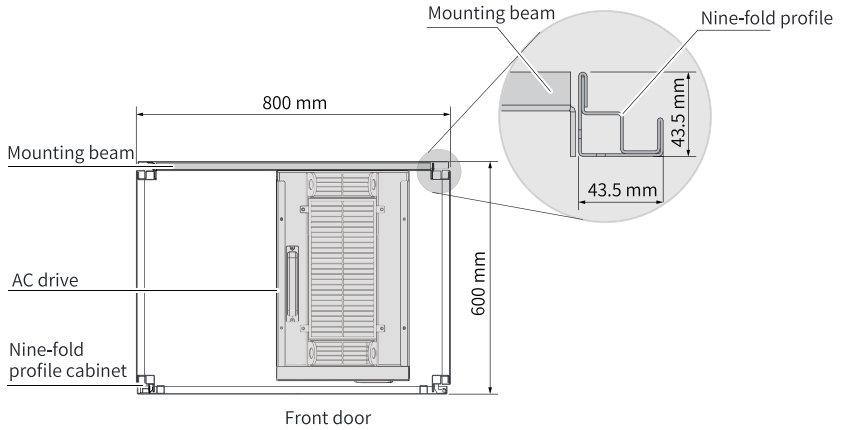

Figure 2-19 Top view of a cabinet for T10 and T12 models

To install T10 to T12 models into the nine-fold profile cabinet with the depth of 600 mm, bend the back mounting board inwards (not required for the cabinet with the depth of 800 mm), as shown in "Figure 2-20 " on page 46 . However, if the cabinet with the depth of 600 mm has both front and back doors, the AC drive cannot be installed in this kind of cabinet. Instead, install the AC drive into the cabinet with the depth of 800 mm.

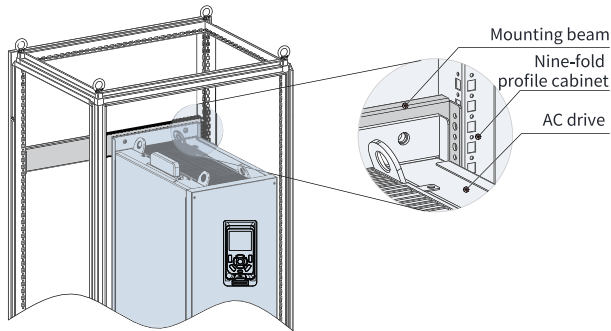

Figure 2-20 3D of a cabinet for T10 and T12 models

2. Fix the bottom mounting bracket in the nine-fold profile cabinet.  
Fix the mounting bracket to the base of the nine-fold profile cabinet by using six M5 self-tapping screws, as shown in "Figure 2-21 " on page 47 .

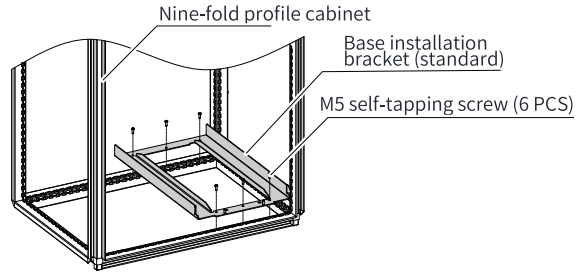

Figure 2-21 Installing the bottom mounting bracket

## Note

If the cabinet used by the customer is not a nine-fold profile cabinet, the fixing holes of the mounting bracket need to be drilled and assembled on site.

3. Assemble the guide rails (model: MD500-AZJ-A3T10) and mount the guide rail assembly to the cabinet.

a. Assemble the guide rail, as shown in ["Figure 2-22 " on page 47 .](#)

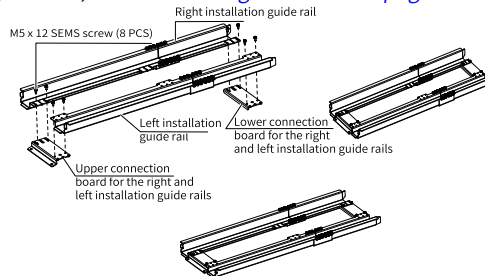

Figure 2-22 Guide rail assembling

b. Align the two round holes at the front end of the mounting rail with the screws of the mounting bracket, and then lock the guide rail to the cabinet with two M6 nuts, as shown in ["Figure 2-23 " on page 48 .](#)

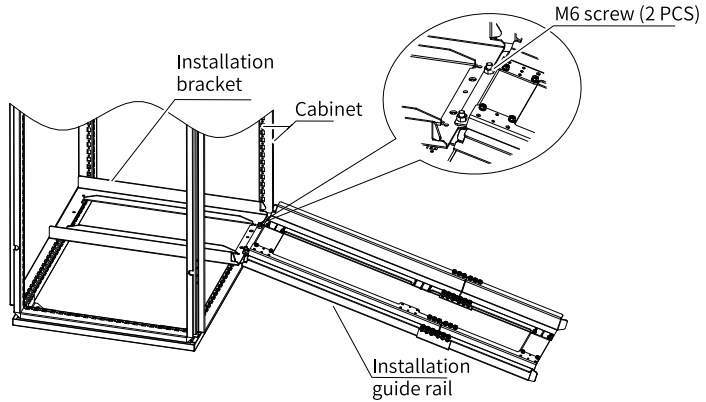

Figure 2-23 Mounting the guide rails on the cabinet

4. Remove the cover from the AC drive.

For details, see the section of removing the front cover. After the front cover is removed, the auxiliary handle will be exposed.

5. Align the AC drive caster with the guide rail and push the drive slowly into the cabinet.

During the push-in or pull-out process, use the auxiliary strap to prevent the drive from toppling over. It is recommended that two people work together.

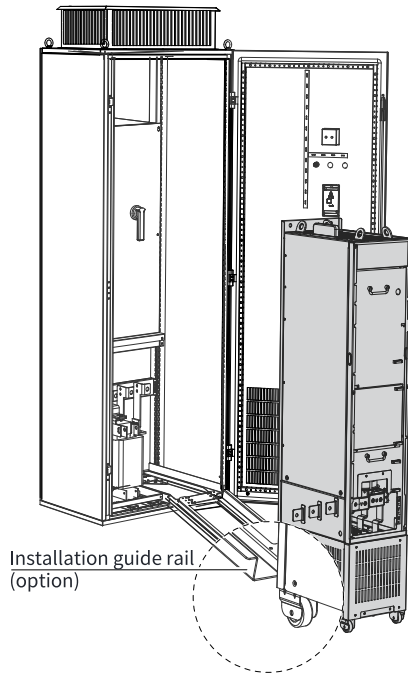

Figure 2-24 Aligning the AC drive caster with the guide rail

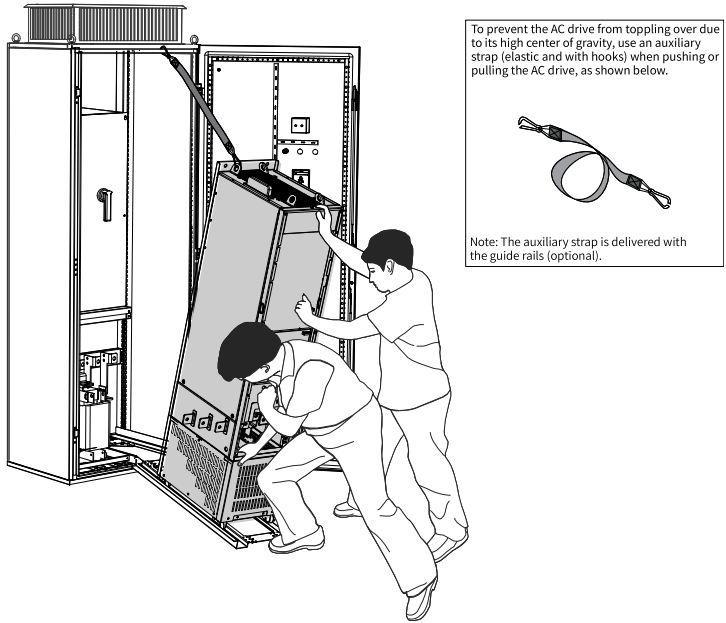

Figure 2-25 Pushing the AC drive into the cabinet

6. Remove the auxiliary strap, install the four screws on the back of the AC drive to fix it to the beam in the cabinet.

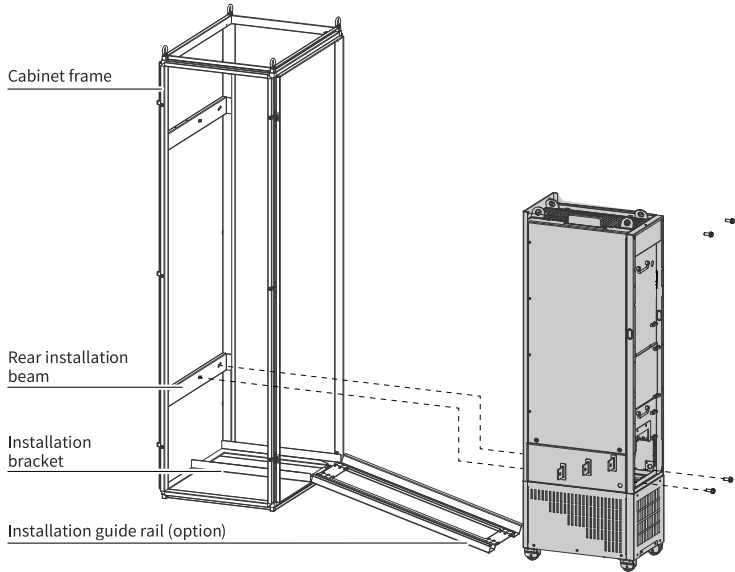

Figure 2-26 Installing the AC drive to the beam

7. After installation is done, remove the guide rail.
8. Remove the air filter paper board at the top of the AC drive. The air filter paper board is used to prevent foreign objects such as screws from falling into the air filter during installation of the AC drive into the cabinet.

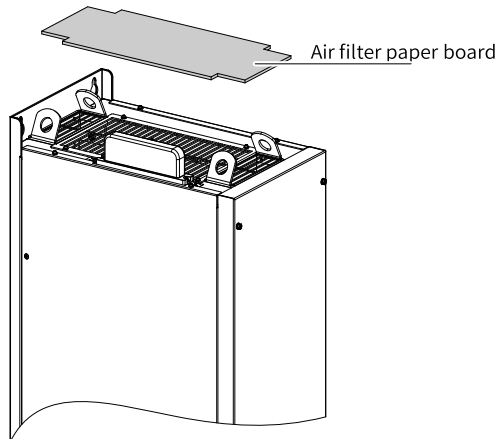

Figure 2-27 Removing the air filter paper board

### 3 Electrical Design

#### 3.1 System Application Wiring

##### 3.1.1 System Connection Diagram

When the AC drive is used to control asynchronous motors, install a variety of electrical devices on the input and output sides of the AC drive to ensure system safety and stability. The following figure shows the system connection diagram of an AC drive (three phase 380 V to 480 V; 0.75 kW).

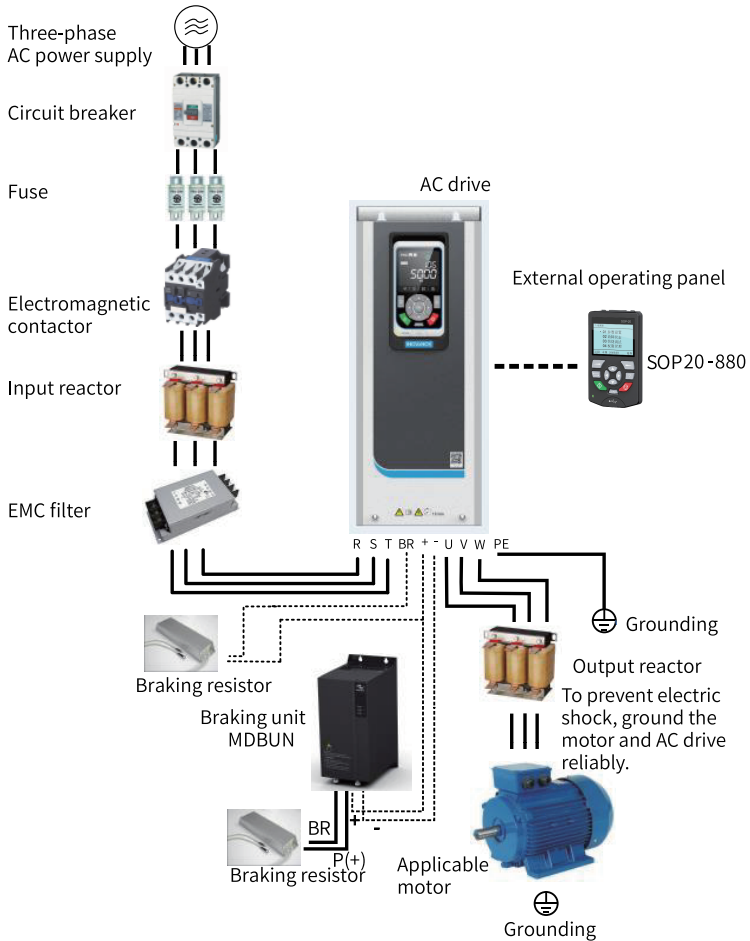

Figure 3-1 System structure

## Note

The figure above shows only the AC drive system connection. For details about peripheral device selection, see ["4.1 Option List" on page 108](#).

Table 3–1 Usage of peripheral electrical devices

Device	Position	Description
Circuit breaker	Between the power supply and the AC drive input side	Short circuit breaker: Cuts off power supply when overcurrent occurs on downstream devices.
		Earth leakage circuit breaker: Provides protection against potential leakage current during AC drive operation to prevent electric shock and even fire. Select proper earth leakage circuit breakers as needed.
Fuse	Between the power supply and the AC drive input side	Protects downstream semiconductor components in case of short circuit.
(Electromagnetic) contactor	Between the circuit breaker and the AC drive input side	Switches on or off the AC drive. Do not start/stop the AC drive frequently by switching on or off the contactor (time interval is at least one hour) or use the contactor to directly start the AC drive.
Input reactor	AC drive input side	Improves the input-side power factor. Eliminates high-order harmonics of the input side effectively and prevents other devices from being damaged due to distortion of voltage waveform. Eliminates input current unbalance due to unbalance between the power phases.
EMC filter	AC drive input side	Reduces conducted and radiated interference that escapes from the AC drive to the outside. Reduces conducted interference from the power supply to the AC drive, improving the anti-interference capacity of the AC drive.
DC reactor	Standard for MD580 series AC drives above 18.5G/22P	Improves the input-side power factor. Improves the efficiency and thermal stability of the AC drive. Eliminates the impact of input high-order harmonics on the AC drive and reduces conducted and radiated interference to the outside.
Braking resistor	75G/90P models and below, containing letter B in the designation	Use a braking resistor for 75G/90P models and below containing letter B in the designation. Dissipates regenerative energy during motor deceleration.

Device	Position	Description
Braking unit	All models not containing letter B in the designation	Use an Inovance braking unit (MDBUN) or recommended braking resistor for all models not containing letter B in the designation. Dissipates regenerative energy during motor deceleration.
Output reactor	Between the AC drive output side and the motor (close to the AC drive)	The output side of the AC drive generally has large high-order harmonics. When a motor is far away from the AC drive, much distributed capacitance exists in the circuit and certain harmonics may cause resonance in the circuit, which will: (a) Degrade motor insulation performance and damage the motor in the long run. (b) Generate large leakage current and trigger AC drive protection frequently. If the distance between the AC drive and motor is greater than 100 m, install an AC output reactor.
dv/dt reactor	AC drive output side (close to the AC drive)	Optional; protects motor insulation and reduces bearing current.
Output magnetic ring	AC drive output side (close to the AC drive)	Reduces bearing current.
Motor	AC drive output side	Select an applicable motor.
Note: For selection of peripheral electrical devices, see "Option Selection".		

## Note

- Do not install a capacitor or surge protection device (SPD) on the output side of the AC drive. Failure to comply will result in AC drive faults or damage to the capacitor or SPD.
- Input/Output (main circuit) of the AC drive contains harmonics, which may interfere with communication devices near the AC drive. Install an anti-interference filter to minimize the interference.

### 3.1.2 Electrical Wiring Diagram

The following figure shows a typical wiring method.

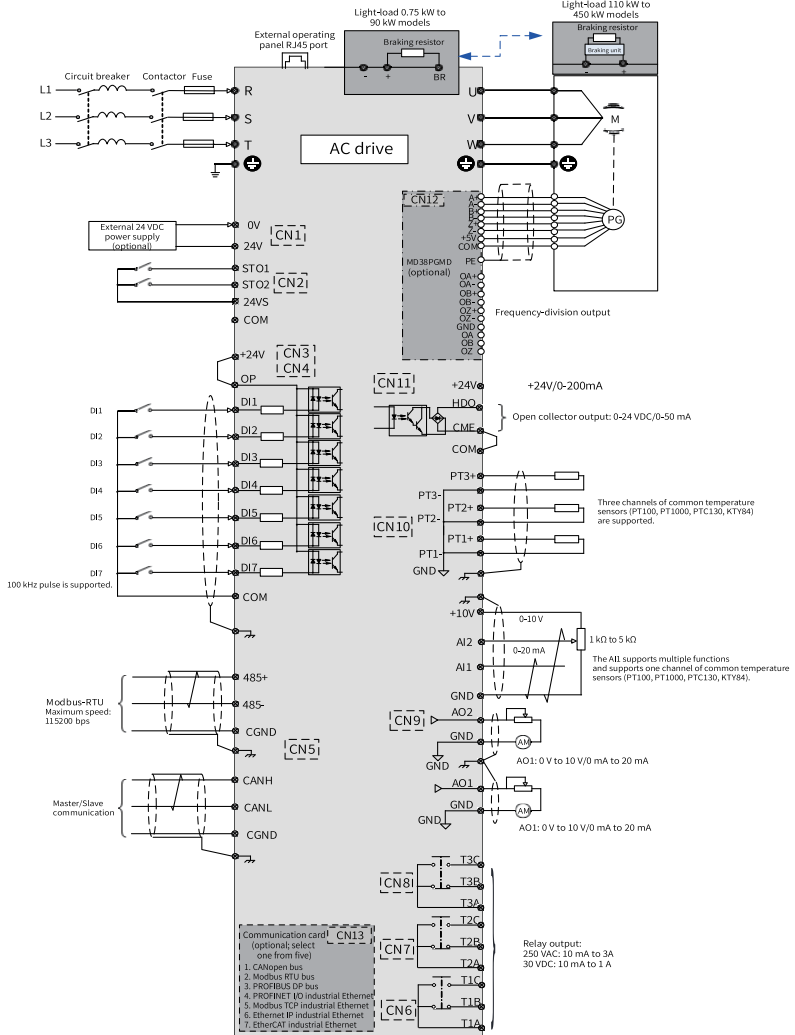

Figure 3-2 Standard wiring

## 3.2 Basic Electrical Safety Precautions

### 3.2.1 Selecting a Power Isolation Device

The drive is equipped with a main isolation device as per standard. Depending on the drive capacity and the options selected, the isolation device can be either a disconnect or an air circuit breaker.

### 3.2.2 Selecting a Main Contactor

Depending on the drive capacity, you can order it with a main contactor (option + F250).

### 3.2.3 Selecting a Supply Transformer

Take the following guidance into consideration:

1. Determine the transformer apparent power according to the following formula:

$$SN \text{ (kVA)} = 1.6 \times \text{Total power of motor shaft (kW)}$$

2. Determine the rated voltage of the secondary winding of the transformer according to the rated input voltage of the drive.

3. Make sure that the transformer meets the grid specifications defined for the drive in the following aspects:

- Rated input voltage, allowable voltage change, and unbalance degree
- Rated frequency and allowable change
- Short circuit withstand strength (IEC) or short circuit current protection (UL or CSA)

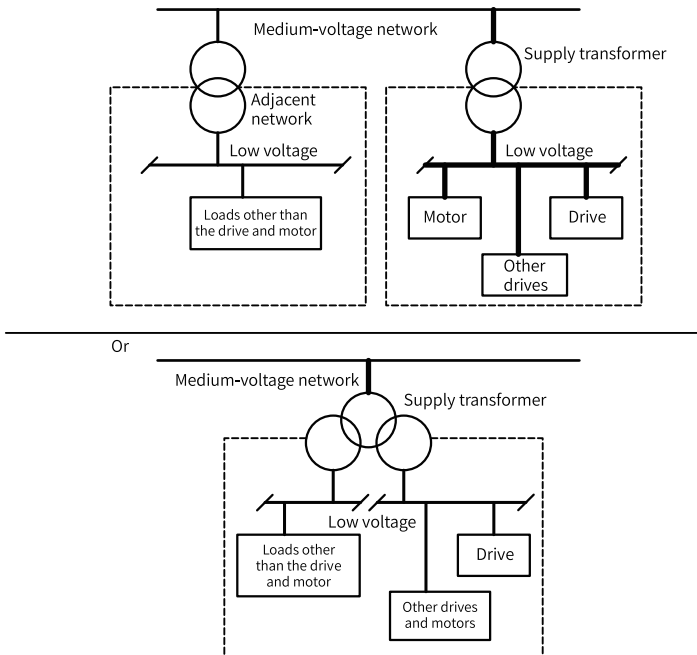

Figure 3-3 Selecting a supply transformer



If capacitive loads (for example, lighting, PC, PLC, and power factor correction capacitors) share one network with the drive, resonance may occur. Resonant current may damage the units on the network.

### 3.2.4 Checking Motor Compatibility

The drive can be used for an AC asynchronous induction motor, a permanent magnet synchronous motor or an AC induction servo motor. One drive can be connected to multiple induction motors.

Based on actual AC line voltage and motor load, select motor capacity and AC drive type from the table of ratings in the "Technical Data" section.

### 3.2.5 Using a PMSM

Only one permanent motor can be connected to the output side of each inverter.

It is recommended that a safety switch be installed between the permanent synchronous motor and the drive. The safety switch can safely disconnect the motor from the drive. According to the safety instructions, ensure that the motor does not send power back to the drive during maintenance.

### 3.2.6 Cable Routing Requirements

#### 1. Separated routing of signal cables and power cables

When analog signals are used for remote control on the cabinet module, separate signal cables from high-voltage circuits (power input, inverter output, and braking resistor connection cables) by a distance above 50 cm to reduce interference from the AC drive and other equipment to analog signals. Comply with this requirement for cable routing even inside the control cabinet.

#### 2. Analog control signal cables

Use shielded twisted pair cables. Minimize the length of unshielded part of the cable (about 5 mm to 7 mm) and wrap the exposed part with insulation tape to prevent the shielded cable from coming into contact with other equipment and incurring interference.

#### 3. Motor cables

Use shielded cables. Minimize the distance between the cabinet module and the motor, and route the motor cables separately from other cables. Also, avoid long-distance parallel routing of the motor cables and other cables to reduce

electromagnetic interference caused by rapid changes in the output voltage of the AC drive.

4. Power cables

Use shielded cables, or shield all the cables from the cabinet module to the motor by using conduits.

5. Control cables and power supply cables

If a control cable must run across a power supply cable, arrange them at an angle close to 90°.

### 3.3 Wiring of the Main Circuit

#### 3.3.1 Descriptions of Main Circuit Terminals

##### T1 to T19 models

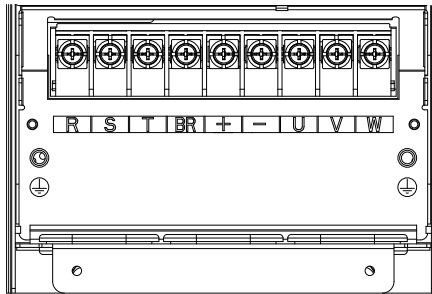

Figure 3-4 Layout of main circuit terminals for T1 to T4 models

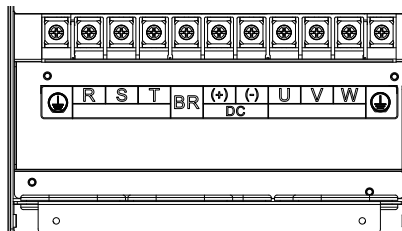

Figure 3-5 Layout of main circuit terminals for T5 to T8 models

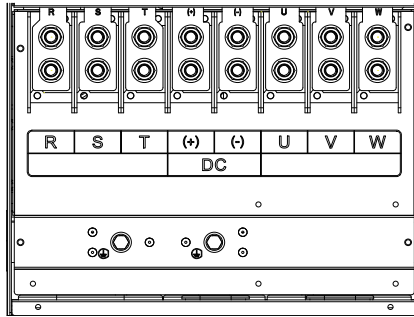



Figure 3-6 Layout of main circuit terminals for T9 models

Table 3-2 Descriptions of main circuit terminals

Terminal Silkscreen	Terminal Name	Function
R, S, T	Three-phase power supply input terminals	Connected to a three-phase AC input power supply
(+), (-)	Positive and negative terminals of the DC bus	Common DC busbar input; connected to the external braking unit of T9 models and above.
(+), BR	Braking resistor connection terminals	Used to connect to the braking resistor of T8 models and below
U, V, W	Output terminals	Connected to a three-phase motor
	Grounding terminal (PE)	The terminal is used for protective grounding.

**T10 to T12 models**

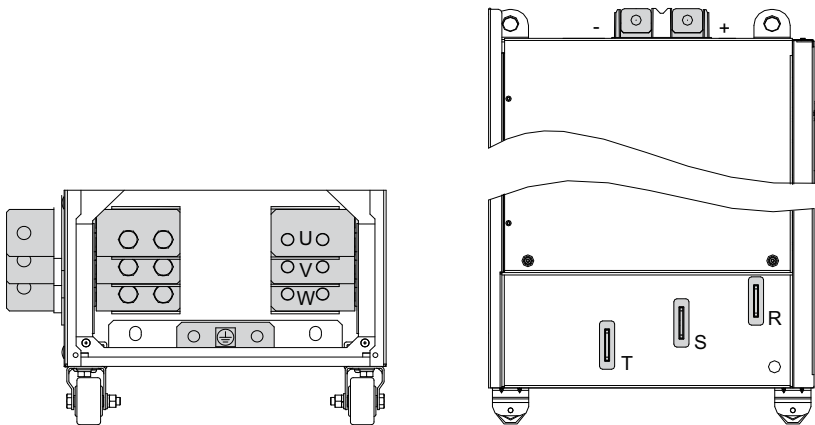



Figure 3-7 Layout of main circuit terminals for T10 to T12 models

Table 3-3 Descriptions of main circuit terminals

Terminal Silkscreen	Terminal Name	Function
R, S, and T	Three-phase power supply input terminals	Connected to a three-phase AC input power supply
+ and -	Positive and negative terminals of the DC bus	Common DC busbar input; connected to an external braking unit.
U, V, W	AC drive output terminals	Connected to a three-phase motor
	Grounding terminal (PE)	The terminal is used for protective grounding.

### 3.3.2 Cable Selection

#### Power cable selection

Follow national or regional regulations when selecting power cables. Selection of IEC cables is based on:

- EN 60204-1 and IEC 60364-5-52 standards
- Copper conductor cable with PVC insulation or other insulation with higher heat resistance
- Heat resistance: ambient temperature of  $\leq 40^{\circ}\text{C}$  and cable surface temperature of  $\leq 70^{\circ}\text{C}$  (Note: When the ambient temperature is above  $40^{\circ}\text{C}$  or below the cable rated minimum, contact Inovance.)
- Symmetrical cables with copper mesh shield

If recommended cables for peripheral devices or options are not suitable for the product, contact Inovance.

As required by EMC standards, use shielded cables. A shielded cable has either three or four phase conductors, as shown in the following figure. If a three-conductor cable is used but its shield cannot provide sufficient conductivity, add an independent PE cable. Alternatively, use a four-conductor cable containing a PE conductor. To suppress radio frequency interference effectively, use coaxial copper braid as the cable shield. To enhance the shielding efficiency and conductivity, ensure that the braided density is greater than 90%.

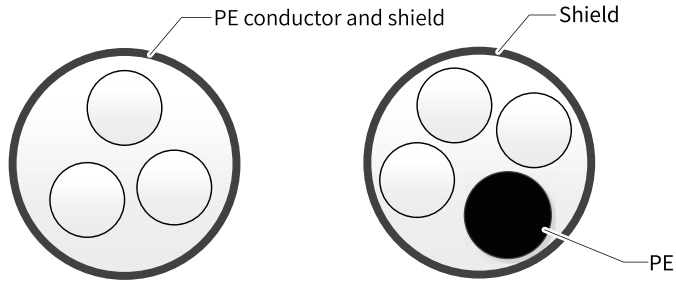

Figure 3-8 Recommended power cable types

## Cable

Table 3-4 Selection of cables (three-phase 380 V to 480 V)

Structure	Model	RST/UWV		Grounding Wire		Screw	Tightening Torque (N · m) (lb/in.)
		Cable (mm <sup>2</sup> ) <sup>&lt;1&gt;</sup>	Cable Lug Model	Cable (mm <sup>2</sup> ) <sup>&lt;1&gt;</sup>	Cable Lug Model		
T1	MD580-4T2R1B	3 x 0.75	TNR1.25-4	0.75	TNR1.25-4	M4	1.2 (10.6)
	MD580-4T3R1B	3 x 0.75	TNR1.25-4	0.75	TNR1.25-4	M4	
	MD580-4T3R8B	3 x 0.75	TNR1.25-4	0.75	TNR1.25-4	M4	
	MD580-4T5R1B	3 x 0.75	TNR1.25-4	0.75	TNR1.25-4	M4	
	MD580-4T7R2B	3 x 1	TNR1.25-4	1	TNR1.25-4	M4	
	MD580-4T9B	3 x 1.5	TNR2-4	1.5	TNR2-4	M4	
T2	MD580-4T13B	3 x 2.5	TNR3.5-4	2.5	TNR3.5-4	M4	
	MD580-4T17B	3 x 4	TNR5.5-4	4	TNR5.5-4	M4	
T3	MD580-4T25B	3 x 6	GTNR6-5	6	GTNR6-5	M5	2.8 (24.8)
	MD580-4T32B	3 x 10	GTNR10-5	10	GTNR10-5	M5	
T4	MD580-4T37B	3 x 10	GTNR10-5	10	GTNR10-5	M5	
T5	MD580-4T45(B)	3 x 16	GTNR16-6	16	GTNR16-6	M6	4.8 (45.2)
	MD580-4T60(B)	3 x 16	GTNR16-6	16	GTNR16-6	M6	
T6	MD580-4T75(B)	3 x 25	GTNR25-6	16	GTNR16-6	M6	
	MD580-4T91(B)	3 x 35	GTNR35-6	25	GTNR25-6	M6	
T7	MD580-4T112(B)	3 x 50	GTNR50-8	35	GTNR35-8	M8	13.0 (115.2)
	MD580-4T150(B)	3 x 70	GTNR70-8	50	GTNR50-8	M8	
T8	MD580-4T176(B)	3 x 95	GTNR95-12	70	GTNR70-12	M12	35.0 (310.1)
	MD580-4T210	3 x 120	GTNR120-12	95	GTNR95-12	M12	
	MD580-4T253	3 x 150	BC150-12	95	GTNR95-12	M12	
T9	MD580-4T304	3 x 185	BC185-12	120	GTNR120-12	M12	
	MD580-4T377	2 x (3 x 95)	GTNR95-12	120	GTNR120-12	M12	
T10	MD580-4T426-L	2 x (3 x 120)	GTNR120-12	150	BC150-12	M12	
	MD580-4T465-L	2 x (3 x 120)	GTNR120-12	150	BC150-12	M12	

Structure	Model	RST/UWV		Grounding Wire		Screw	Tightening Torque (N · m) (lb/in.)
		Cable (mm <sup>2</sup> ) <sup>&lt;1&gt;</sup>	Cable Lug Model	Cable (mm <sup>2</sup> ) <sup>&lt;1&gt;</sup>	Cable Lug Model		
T11	MD580-4T520-L	2 x (3 x 150)	BC150-12	185	BC185-12	M12	85.0 (753.1)
	MD580-4T585-L	2 x (3 x 185)	BC185-12	240	BC240-12	M12	
T12	MD580-4T650-L	2 x (3 x 185)	BC185-16	240	BC240-16	M16	
	MD580-4T725-L	2 x (3 x 240)	BC240-16	300	BC300-16	M16	
	MD580-4T820-L	2 x (3 x 300)	BC300-16	300	BC300-16	M16	

Table 3–5 Selection of cables (three-phase 380 V to 480 V) (UL-compliant)

Structure	Model	RST/UWV		Grounding Wire		Screw
		Cable (AWG/mil) <sup>&lt;2&gt;</sup>	Cable Lug Model	Cable (AWG/kcmil) <sup>&lt;2&gt;</sup>	Cable Lug Model	
T1	MD580-4T2R1B	18	TLK0.75-4	18	TLK0.75-4	M4
	MD580-4T3R1B	18	TLK0.75-4	18	TLK0.75-4	M4
	MD580-4T3R8B	18	TLK0.75-4	18	TLK0.75-4	M4
	MD580-4T5R1B	18	TLK0.75-4	18	TLK0.75-4	M4
	MD580-4T7R2B	16	TLK1.5-4	16	TLK1.5-4	M4
	MD580-4T9B	14	TLK2.5-4	14	TLK2.5-4	M4
T2	MD580-4T13B	14	TLK2.5-4	14	TLK2.5-4	M4
	MD580-4T17B	12	TLK4-4	12	TLK4-4	M4
T3	MD580-4T25B	10	TLK6-5	10	TLK6-5	M5
	MD580-4T32B	8	TLK10-5	8	TLK10-5	M5
T4	MD580-4T37B	6	TLK16-5	6	TLK16-5	M5
T5	MD580-4T45(B)	6	TLK16-5	6	TLK16-5	M5
	MD580-4T60(B)	4	TLK25-6	4	TLK25-6	M6
T6	MD580-4T75(B)	2	TLK35-6	4	TLK25-6	M6
	MD580-4T91(B)	2	TLK35-6	2	TLK35-6	M6
T7	MD580-4T112(B)	1/0	TLK50-8	2	TLK35-8	M8
	MD580-4T150(B)	2/0	TLK70-8	1/0	TLK50-8	M8
T8	MD580-4T176(B)	3/0	TLK95-12	2/0	TLK70-12	M12
	MD580-4T210	4/0	TLK120-12	3/0	TLK95-12	M12
	MD580-4T253	250 kcmil	SQNBS150-12	3/0	TLK95-12	M12
T9	MD580-4T304	400 kcmil	SQNBS250-12	250 kcmil	SQNBS150-12	M12
	MD580-4T377	2 x 3/0	TLK95-12	250 kcmil	SQNBS150-12	M12
T10	MD580-4T426(-L)	2 x 250 kcmil	SQNBS150-12	300 kcmil	SQNBS150-12	M12
	MD580-4T465(-L)	2 x 250 kcmil	SQNBS150-12	300 kcmil	SQNBS150-12	M12
T11	MD580-4T520(-L)	2 x 300 kcmil	SQNBS150-12	400 kcmil	SQNBS250-12	M12
	MD580-4T585(-L)	2 x 400 kcmil	SQNBS250-12	500 kcmil	SQNBS250-12	M12
T12	MD580-4T650(-L)	2 x 400 kcmil	TLK240-16	500 kcmil	TLK400-16	M16
	MD580-4T725(-L)	2 x 500 kcmil	TLK400-16	650 kcmil	TLK400-16	M16
	MD580-4T820(-L)	2 x 500 kcmil	TLK400-16	650 kcmil	TLK400-16	M16

## Note

<1>: GB standards apply. For example, 3 x 10 indicates one 3-conductor cable; 2 x (3 x 95) indicates two 3-conductor cables. <2>: AWG standards apply. For example, 5 indicates 5 AWG; 1/0 indicates 0 AWG; 2/0 indicates 00 AWG; 3/0 indicates 000 AWG; 4/0 indicates 0000 AWG; 2 x 250 indicates two 250 kcmil cables.

## Recommended Lug

The preceding recommended lugs are the TNR, GTNR, and BC series of Suzhou Yuanli. The lugs with UL certifications are the TLK and SQNBS series of KST.

Table 3-6 Appearance, models, and dimensions of TNR series lugs (unit: mm)

Model	Cable Size	D	d1	E	F	B	d2	L	Current (A)	Crimping Tool
	AWG									
TNR1.25-4	22 to 16	3.4	1.9	4.6	7.3	8.1	4.3	16	19	RYO-8 AK-1M
TNR2-4	16 to 14	4	2.4	4.8	7.75	8.5	4.3	16.8	27	
TNR3.5-4	12 to 10	5	3.2	6.8	8.2	9.5	4.3	20	37	
TNR5.5-4	12 to 10	5.6	3.5	7	8.25	9.5	4.3	20	48	

Table 3-7 Appearance, models, and dimensions of GTNR series lugs (unit: mm)

Model	D	d1	E	H+K	B	d2	F	L	Crimping Tool
GTNR6-5	6	4.2	9	9	10	5.3	1.4	23.8	RYO-8 YYT-8 RYO-14
GTNR10-5	7	5	9	11.5	12.4	5.3	1.45	27.5	
GTNR16-6	7.8	5.8	12	12	12.4	6.4	1.7	31	CT-38 CT-100
GTNR25-6	9.5	7.5	12	12.5	14	6.4	1.9	32	
GTNR35-6	11.4	8.6	15	14	16.5	6.4	2.7	38	
GTNR50-8	12.6	9.6	16	17	18	8.4	2.8	43.5	CT-100
GTNR70-8	15	12	18	20	21	8.4	2.8	50	
GTNR95-12	17.4	13.5	20	22	25	13	3.9	55	
GTNR120-12	19.8	15	22	24	28	13	4.7	60	RYC-150

Table 3-8 Appearance, models, and dimensions of BC series lugs (unit: mm)

Model	A	B	W	E	D	L	T	C	F
150-12	21	16.5	30	16.5	27	78	4.5	12.8	16.5
185-12	23	18.5	33.5	16.5	30	82	4.5	12.8	16.5
185-16								16.7	
240-16	26	21	37.7	18	32	88	5	16.7	17
300-16	28	23	41	18	37	97	5	16.7	17

### 3.3.3 Circuit Wiring Requirements

#### Wiring of the main circuit

- Terminals BR, (-), and (+) are used to connect optional parts. Do not connect them to any AC power supply.
- To protect the main circuit, separate it from all surfaces that may come into contact with it and provide covers as required.
- The control circuit is a safety extra-low voltage (SELV) circuit, which must be isolated from other circuits through reinforced insulation. Make sure that the control circuit is connected to an external SELV circuit.
- Prevent foreign objects from entering the wiring area of the terminal block.
- Do not solder stranded conductors.
- Different terminals may need different tightening torque. Tighten the terminal screws as specified. Use screwdrivers, ratchets, or wrenches as appropriate.
- When using an electric tool to tighten the terminal screws, set the tool to a low speed to avoid damage to the terminal screws.
- Tighten the terminal screws with an angle not greater than 5°. Failure to comply may result in damage to the terminal screws.

#### Power cable selection

Follow national or regional regulations when selecting power cables. Selection of IEC cables is based on:

- EN 60204-1 and IEC 60364-5-52 standards
- Copper conductors with PVC insulation
- Heat resistance: 40°C ambient temperature and 70°C cable surface temperature (Note: When the ambient temperature exceeds 40°C, contact Inovance.)
- Symmetrical cables with copper mesh shield

---

#### **Note**

If recommended cables for peripheral devices or options are not suitable for the AC drive, contact Inovance technical service personnel.

---

As required by EMC standards, use shielded cables. A shielded cable has either three or four phase conductors, as shown in the following figure. If a three-conductor cable is used but its shield cannot provide sufficient conductivity, add an independent PE cable. Alternatively, use a four-conductor cable containing a PE conductor. To suppress radio frequency interference effectively, use coaxial copper braid as the cable shield. To enhance the shielding efficiency and conductivity, ensure that the braided density is greater than 90%.

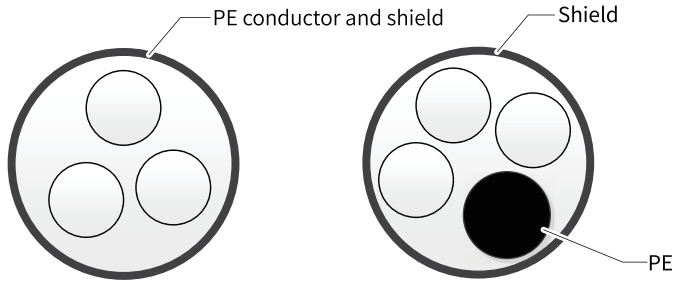

Figure 3-9 Recommended power cable types

**Cable routing of the main circuit**

The power input cable of the AC drive and the motor cable can generate strong electromagnetic interference. To avoid electromagnetic interference caused by long-distance parallel coupling between the high-interference cables and the control circuit, keep the main circuit cables more than 30 cm away from signal cables. Common main circuit cables include input R/S/T cables, output U/V/W cables, DC bus, and brake cables. Signal cables include I/O signal cables, communication cables, and encoder cables.

Cable ducts must be securely connected and well grounded. Use aluminum cable ducts to ensure the equipotentiality of the AC drive. Connect the filter, AC drive, and motor to the system (machinery or appliance) properly. Protect all connections with spray coating and ensure good contact of conductive metal.

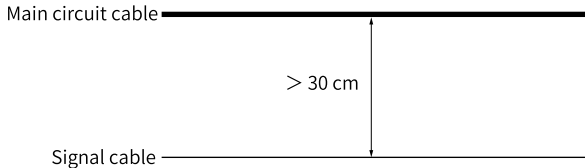

Figure 3-10 Cable routing

**Wiring in an IT or angular grid system**

Before wiring in an IT or angular grid system, disconnect the optional EMC grounding screw. Failure to comply may result in damage to the AC drive or injury.

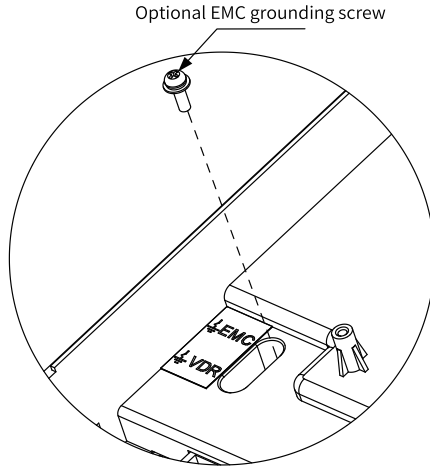

Figure 3-11 Disconnecting the optional EMC grounding screw

### Shield of motor cables

Use shielded cables for motor output. Use a grounding bracket to achieve all-round connection with the shield, and crimp the drain wire of the shield to the PE terminal. The following figure shows the shield wiring.

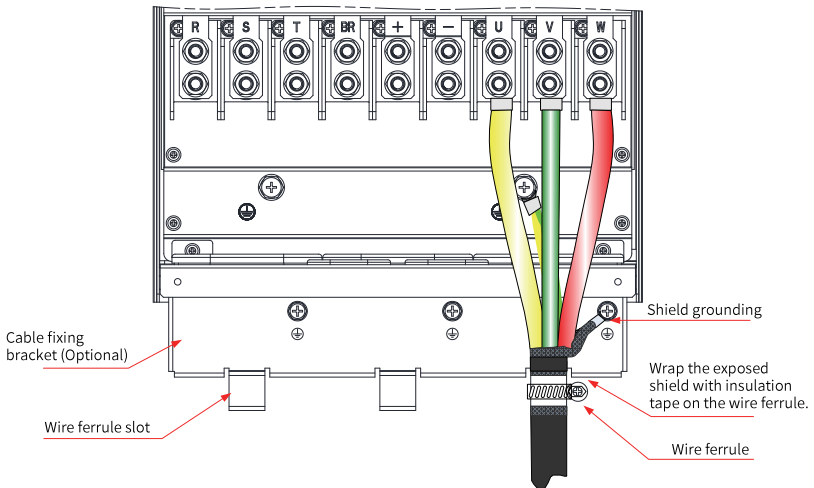

Figure 3-12 Shield wiring

For the motor cable shield, use the shortest possible drain wire with a width no less than one-fifth of its length.

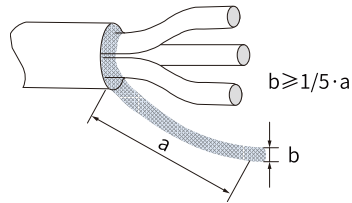

Figure 3-13 Drain wire of the motor cable shield

### Length of motor cables

When the AC drive is working, the quick on-off of its power switch triode can lead to excessively large  $dU/dt$  at the output side. If the motor cable is too long, the motor winding will experience excessive voltage stress that may cause insulation breakdown. Therefore, use motors that comply with IEC60034-25 IVIC B requirements or motors featuring high withstand voltage. In addition, distributed capacitance on a cable increases linearly with the length of the cable, and may easily result in harmonic current.

When using a motor cable longer than the maximum length indicated in the following table, install an output reactor at the output side of the AC drive, or use a motor conforming to IEC60034-25 IVIC B. The output reactor can reduce the voltage stress on the motor winding.



Table 3-9 Requirement for output reactor based on cable length and motor types

AC Drive Rated Power (kW)	Maximum Cable Length of Common Asynchronous Motor (m)	IEC60034-25 IVIC B Motor	Common Asynchronous Induction Motor
0.4 to 3.7	50 m	Not required	Required
5.5	70 m	Not required	Required
7.5	100 m	Not required	Required
11	110 m	Not required	Required
15	125	Not required	Required
18.5	135	Not required	Required
22	150	Not required	Required
$\geq 30$	150	Not required	Required

### 3.3.4 Cable Lug Selection

Cable lugs recommended in the following table are GTNR series and BC series of Suzhou Yuanli.

Table 3-10 Appearance of cable lugs

Series	Appearance
GTNR	 A cylindrical metal cable lug with a circular eyelet on one end and a tapered, cylindrical end on the other.
TNR	 A metal cable lug with a circular eyelet on one end and a cylindrical end on the other, similar to GTNR but with a different profile.
BC	 A metal cable lug with a circular eyelet on one end and a flat, rectangular end on the other.

## 3.4 Control Circuit Wiring

### 3.4.1 Descriptions of Control Circuit Terminals

"Figure 3-14 " on page 70 shows the layout of control circuit terminals.

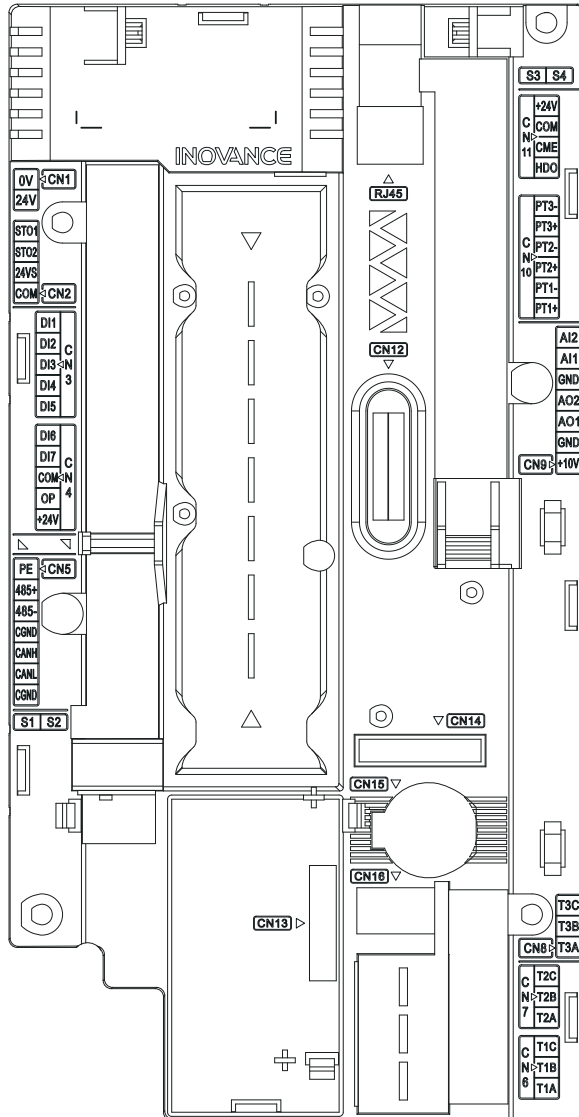

Figure 3-14 Layout of control circuit terminals

Table 3–11 Functions of control circuit terminals

External Interface	Terminal Type	Terminal Name	Description	Specification
CN3	Digital input terminal	DI1-OP	Common multi-function input terminals	Isolated sink/source input programmable terminal; input frequency: < 100 Hz; OP is internally isolated from COM and 24V, and externally shorted to +24V using a jumper by default.
		DI2-OP		
		DI3-OP		
		DI4-OP		
		DI5-OP		
CN4		DI6-OP	Multi-function high-speed pulse input terminal	Maximum input frequency: 100 kHz; can be used as the common DI
CN11	Digital output terminal	HDO-CME	Programmable pulse frequency output	The internal emitter is connected to COM. It can be used as the common programmable open collector terminal that supports 24 VDC/50 mA. The maximum output frequency is 100 kHz. CME is isolated from COM and GND internally, and shorted to COM using a jumper by default.

External Interface	Terminal Type	Terminal Name	Description	Specification
CN9	Analog input terminal	AI1-GND	Analog single-ended input channel AI1	0 V to 10 V or 0 mA to 20 mA; 12-bit resolution; correction accuracy: $\pm 1\%$ ; input impedance in voltage input mode: 22.1 k $\Omega$ ; input impedance in current input mode: 500 $\Omega$ or 250 $\Omega$ AI1 supports input from the temperature sensor, including the PT100, PT1000, KTY84, and PTC. See parameters in group F and see function guide for detailed usage.
		AI2-GND	Analog single-ended input channel AI2	0 V to 10 V or 0 mA to 20 mA; 12-bit resolution; correction accuracy: 0.5%; input impedance in voltage input mode: 22.1 k $\Omega$ ; input impedance in current input mode: 500 $\Omega$ or 250 $\Omega$ See parameters in group F and see function guide for detailed usage.
	Analog output terminal	AO1-GND	Analog single-ended output channel AO1	0 V to 10 V (default mode) or 0 mA to 20 mA; 12-bit resolution; correction accuracy: 1%; maximum load output current in voltage mode: 2 mA; load impedance in voltage mode: > 5 k $\Omega$ ; load impedance in current mode: < 500 $\Omega$
		AO2-GND	Analog single-ended output channel AO2	
	On-board power supply output terminal	+10V-GND	10 V analog voltage output	10 V $\pm 10\%$ ; maximum current: 10 mA; GND is isolated from COM and CME internally.
		+24V-COM	On-board 24 V to power external devices	24 V $\pm 10\%$ ; no-load voltage: $\leq 30$ V; maximum output current: 200 mA; internally isolated from OP/CME/GND
CN1	Terminal for input of external 24 V power supply	24V-0V	Terminal for input of external 24 V power supply	Terminal for input of external 24 V power supply; maximum input voltage: 30 V; used by the control board; minimum input current: 1 A; 0V is isolated from COM, CME, and GND internally.
CN2	STO terminal	STO1	STO2	Internal connection: By default, STO1 and STO2 are connected to +24VS by using a jumper upon factory delivery. External connection: STO1, STO2, and +24VS can be connected to an external 24 V power supply. See the STO function for the detailed wiring.
		STO2	STO2	
		+24VS	STO1 and STO2 power supply+	
		COM	STO1 and STO2 power supply ground	

External Interface	Terminal Type	Terminal Name	Description	Specification
CN6	Relay output	TA1/ TB1/ TC1	TA-TB: normally closed TA-TC: normally open	Contact capacity: 250 VAC/3 A (Cosφ = 0,4)
CN7		TA2/ TB2/ TC2		
CN8		TA3/ TB3/ TC3		
CN5	RS-485 communication	C485+	RS-485 communication signal (+)	External RS-485 communication, standard Modbus RTU
		C485-	RS-485 communication signal (-)	
		CGND	RS-485 communication signal ground	
	CAN communication	CANH	CAN_H signal of CAN communication	Master and slave CAN communication; master and slave synchronization supported
		CANL	CAN_L signal of CAN communication	
		CGND	CAN communication signal ground	
RJ45	Operating panel RS-485 communication	RS485+	RS-485 communication signal (+)	RS-485 internal bus, used for commissioning by using the LED operating panel, external LCD operating panel, or PC
		RS485-	RS-485 communication signal (-)	
		GND	RS485 communication signal ground	
CN10	Temperature sensor	PT1+, PT1-	Three-channel temperature sensor input	Three channels of common temperature sensors (PT100, PT1000, PTC, KTY84) supported; temperature display on the operating panel by setting parameters in group F; parameters related to temperature offset correction contained in group F
		PT2+, PT2-		
		PT3+, PT3-		

External Interface	Terminal Type	Terminal Name	Description	Specification
-	DIP switch	S1	Board-mounted RS-485 communication resistor switch	Connected by default
		S2	CANlink communication resistor switch	Connected by default
		S3	Operating panel RS-485 communication resistor switch	Connected by default
		S4	Operating panel CAN communication resistor switch	Connected by default; reserved
CN13	Communication expansion card terminal	J15	Communication expansion card terminal	The following communication expansion cards are supported: CANopen communication card MD580-SI-CAN1, Modbus RTU communication card MD580-SI-RS1, PROFIBUS DP communication card MD580-SI-DP1, PROFINET IO communication card MD580-SI-PN1, Modbus TCP communication card MD580-SI-EM1, EtherCAT communication card MD580-SI-ECAT1, and EtherNet/IP communication card MD580-SI-EN1.
CN14	I/O expansion card terminal	J3	I/O expansion card terminal	I/O expansion card MD580-IO-RD1 supported

## Note

- If the ambient temperature exceeds 23°C, derate the output current by 1.8 mA for every additional 1°C. The maximum output current is 170 mA at 40°C. When OP is shorted to 24V, the DI terminal current must be considered.
- Based on the maximum output voltage of the signal source, select 500 Ω or 250 Ω impedance. For example, if 500 Ω is selected, keep the maximum output voltage not lower than 10 V so that AI2 can detect 20 mA current.

Table 3–12 Terminal descriptions

External Interface	Terminal Name	Terminal Type	Signal Type
CN1	J32	Pluggable terminal block	Terminal for input of external 24 V power supply
CN2	J33	Pluggable terminal block	Safety function
CN3	J34	Pluggable terminal block	Common digital input
CN4	J35	Pluggable terminal block	Common and high-speed digital input
CN5	J36	Pluggable terminal block	RS-485/CAN communication
CN6	J31	Pluggable terminal block	Relay 1
CN7	J30	Pluggable terminal block	Relay 2
CN8	J29	Pluggable terminal block	Relay 3
CN9	J40	Pluggable terminal block	AI, AO, 10 V output
CN10	J39	Pluggable terminal block	Temperature sensor
CN11	J38	Pluggable terminal block	HDO, 24 V output
RJ45	J42	RJ45	External commissioning
CN12	J4	FPC	Encoder
CN13	J15	Box header connector	Communication expansion card
CN14	J3	Female header	I/O expansion card

### 3.4.2 Control Circuit Terminal Wiring

For details on the grounding bracket of the control cable shield, see section Installing the Grounding Bracket of the Cable Shield in *MD580 Series Low-Voltage High-Performance Engineering AC Drive Installation Guide*.

#### Wiring AI1

Weak analog voltage signals are prone to suffer external interference. Therefore, a shielded cable is required, and the wiring distance must be as short as possible (no longer than 20 m), as shown in *"Figure 3–15 AI wiring" on page 76*. In scenarios where analog signals experience severe external interference, install a filter capacitor or a

ferrite magnetic core on the analog signal source. Connect the drain wire of the shield of the analog input cable to the PE terminal of the AC drive.

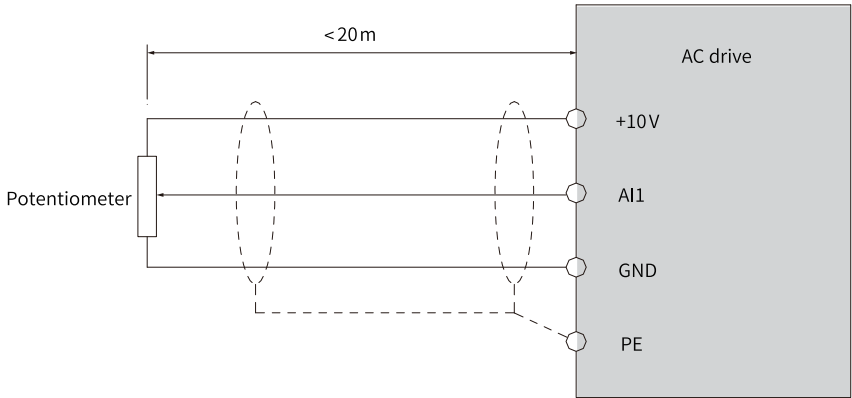

Figure 3-15 AI wiring

### Wiring AI2/AI3

- When AI1 is used for voltage signal input, check whether the temperature detection function of AI1 is invalid (invalid by default). When AI1 is used to collect temperature data, set the AI temperature detection parameter in F6 group to the sensor type that detects temperature.
- When AI1/AI2 is used for current signal input, the current flows to the AI1/AI2 terminal and the current flows from the GND terminal. Set related parameters through the operating panel to switch to the current mode. For details, see the software guide.

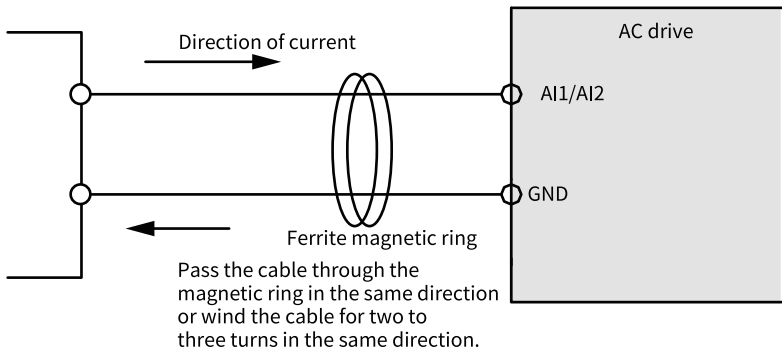
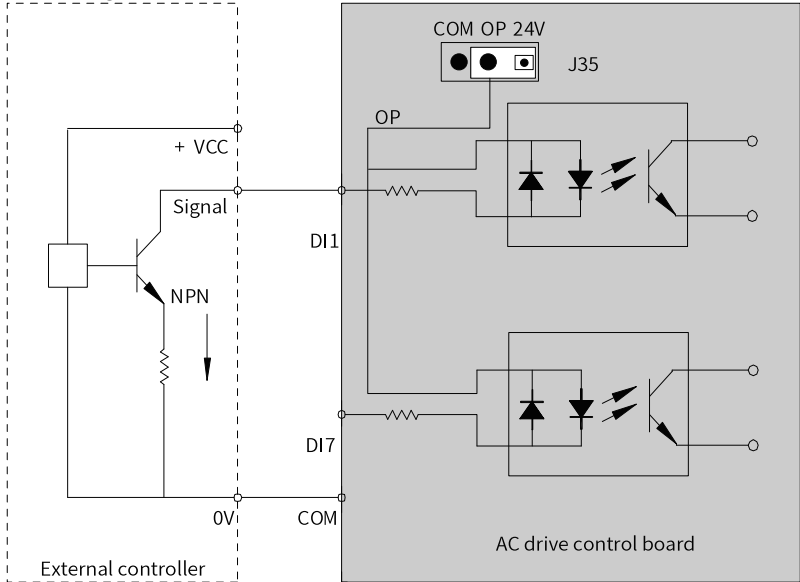

Figure 3-16 Wiring AI1/AI2

## Wiring DI1 to DI7

- Sink wiring mode



Sink wiring mode when the internal 24 V power supply of the AC drive is used

Figure 3-17 Sink wiring mode

To use the internal 24 V power supply, which is the most commonly used method, short OP and 24V of the jumper terminal J35-CN4 on the AC drive control board, and connect the COM terminal of the AC drive to the 0V terminal of the external controller.

In the mode, the DIs of different AC drives cannot be connected in parallel. Otherwise, the DI may malfunction. If DIs of different AC drives must be connected in parallel, connect the anode of a diode to the DI in series and the diode needs to satisfy the following requirement:  $I_F > 40 \text{ mA}$  and  $V_R > 40 \text{ V}$ , as shown in ["Figure 3-18 Parallel connection of DIs of multiple AC drives in the sink mode" on page 78.](#)

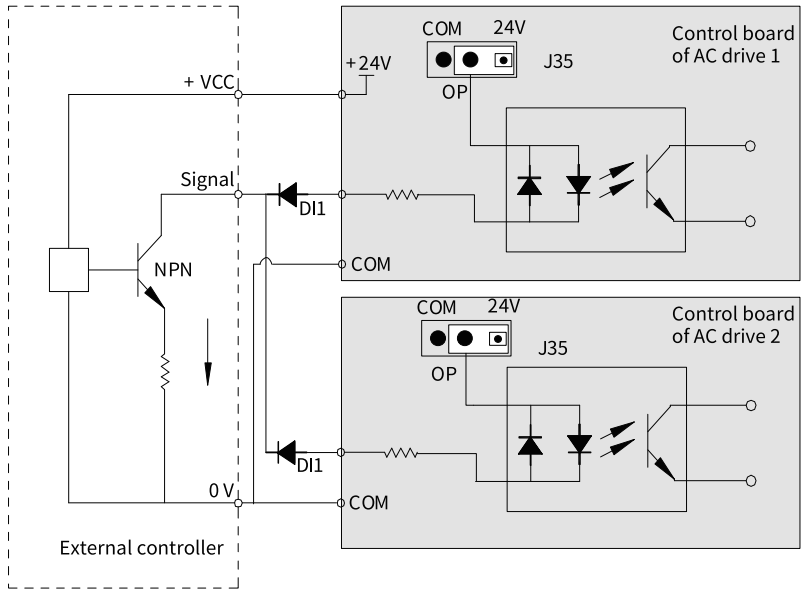

Figure 3-18 Parallel connection of DI terminals of multiple AC drives in the sink mode

● Source wiring mode

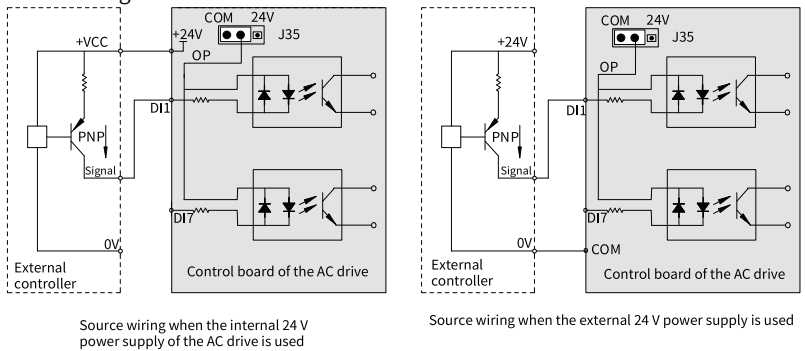

Figure 3-19 Source wiring mode

- To use the internal 24 V power supply, short OP and 24V of the jumper terminal J35-CN4 on the AC drive control board, and connect the COM terminal of the AC drive to the 0V terminal of the external controller.
- To use the external power supply, short OP and COM of the jumper terminal J35-CN4 on the AC drive control board, connect the COM terminal of the AC drive to the 0V terminal of the external controller, and connect the anode of the 24 V external power supply to the DI through the control contact on the external controller.

## Wiring the DO

When the DO needs to drive a relay, connect a snubber diode on both sides of the relay coil. Otherwise, the 24 VDC power supply may be damaged. Ensure that the driving capacity does not exceed 50 mA.

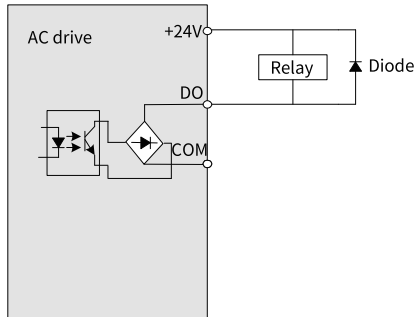

Figure 3-20 Wiring the DO

## Note

Ensure correct direction of electrodes when installing the snubber diode. Failure to comply may result in burnout of the 24 VDC power supply upon output from the digital output terminal.

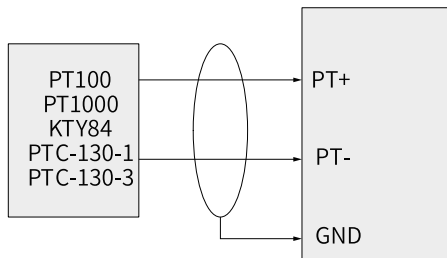

Figure 3-21 Wiring the PT temperature detector

## Note

- The MD580 series AC drive supports simultaneous temperature sampling in four channels, each of which supports four types of temperature sensors.
- All terminals have the multiplexing function. Set the parameters in group F6 for temperature detection. For specific parameter settings, see software-related chapters and sections.
- A temperature drift may be present due to device characteristics when the temperature sampling circuit works under high or low temperature.

## Wiring the relay output terminal

The inductive load (relay, contactor, and motor) causes voltage peak after the current is disconnected. To minimize the interference at cutoff, use a voltage dependent resistor (VDR) at the relay contact for protection and install absorption circuits such as VDRs, RC absorption circuits, and diodes on the inductive load, as shown in "Figure 3-22 Anti-interference processing of relay output terminals" on page 80.

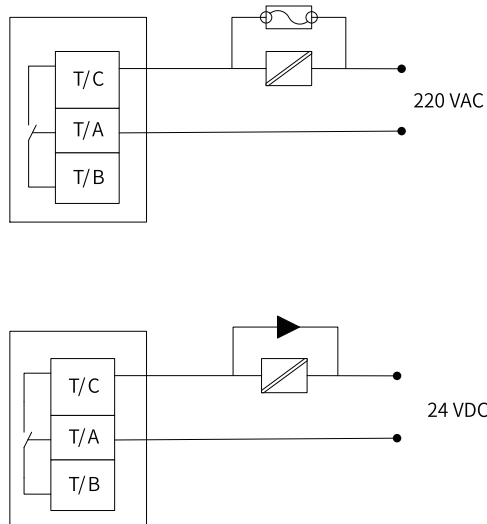

Figure 3-22 Anti-interference processing of relay output terminals

## Note

Use a category 2 power supply for the control circuit. Failure to comply may degrade the operating performance of the AC drive.

## Requirements on tubular terminals

Use tubular terminals with insulation sheath. Keep the exposed conductor of a single or twisted cable no longer than 6 mm, as shown in ["Figure 3–23 Requirements on tubular terminals of the control circuit cable" on page 81.](#)

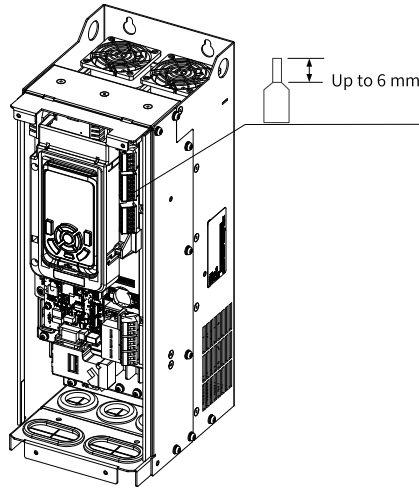

Figure 3-23 Requirements on tubular terminals of the control circuit cable

Table 3–13 Control circuit cable specifications

Single Cable mm <sup>2</sup> (AWG)	Twisted Cable mm <sup>2</sup> (AWG)	Tightening Torque (N · m)
0.2 to 0.75 (24AWG to 18AWG)		0.565

## Note

- The diameter of single-conductor cables must be at least 18 AWG. The diameter of non-shielded twisted pair cables must be at least 20 AWG.
- The diameter of cables with three or more conductors must be at least 24 AWG.
- For cables thicker than 18 AWG, the crimped terminal conductor must be 6 mm to 8 mm in length, and no upper cover is allowed to avoid stress on the terminal and PCB.

### 3.4.3 Control Circuit Wiring Requirements

---

#### **Note**

Wire the control circuit cable according to EN 60204-1.

---

#### **Selection requirements**

To avoid the influence of strong external interference noise on the control circuit, it is recommended that the shielded cable with shield be used as the signal cable. The shield must be connected to the equipment in 360° with signal shielding brackets at both ends of the shield. Use a separate shielded cable for each type of analog signal. Use shielded twisted pair cables for digital signals.

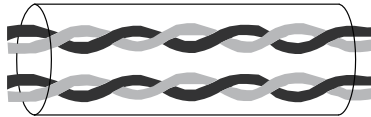

Figure 3-24 Shielded twisted pair

#### **Requirements on shield grounding for analog terminals**

Weak analog voltage signals are susceptible to external interference. Therefore, a shielded cable is typically required, and the wiring distance should be as short as possible (within 20 m). In scenarios where analog signals experience severe external interference, install a filter capacitor or a ferrite core on the analog signal source.

Use shielded cables together with a shield grounding bracket (optional) to achieve all-round grounding of the cable shield.

#### **Wiring requirements for encoder signal cables**

The AC drive is grounded as a whole in structure. When wiring the encoder after PG card installation, connect the encoder signal cable shield to the PE terminal of the PG card to complete shield grounding. Wire the encoder in accordance with the following requirements:

1. During on-site installation and commissioning, route the encoder cable and power cable in different cable ducts. Failure to comply may result in encoder interference.
2. It is recommended to use the shielded twisted pairs. For differential encoders, the cable shield must be connected to the PE terminal of the AC drive according to the differential pair wire.
3. In some scenarios with large-scale equipment, where the AC driver is far away from the motor (the motor cable may be as long as 10 m), the grounding impedance of the encoder cable shield is increased due to parasitic inductance of the cable. In this case, you can disconnect the encoder shield from the PE terminal of the driver.

## Wiring requirements for I/O signal cables

- I/O signals include analog input (AI) signals, analog output (AO) signals, digital input (DI) signals, digital output (DO) signals, and relay output signals. Before wiring the I/O terminals, disconnect the main power supply and ensure that the danger indicator of the AC drive is off.
- Separate I/O signal cables from the main circuit cables (RST and UVV) and other power cables (or electric power cables) by at least 30 cm. Failure to comply may result in interference to I/O signals.
- Separate the cable connecting the relay output terminal from other I/O signal cables by a distance greater than 30 cm. Failure to comply may result in malfunction of the AC drive and equipment.

## 3.5 Communication Connection

### 3.5.1 CANopen Communication

#### 3.5.1.1 Overview

MD580-SI-CAN1 is a new-generation fieldbus adaption module of Inovance. It is used together with the MD580 series AC drive to realize networking and remote control of the transmission system through the CANopen fieldbus communication network.

Features:

- With the Node Guard protocol supported, the master can read equipment status.
- With the Heartbeat protocol supported, the slave reports its current status to the master regularly.
- MD580-SI-CAN1 supports transmission of PDO data which is 16-bit.
- The SDO can be transmitted only via acceleration transmission mechanism. At most four channel's data can be transmitted per each frame.
- The CANIDs of all commands are default values of connections defined in CANopen DS301.
- MD580-SI-CAN1 is installed in the expansion slot of the MD580 without the external power supply.

### 3.5.1.2 Electrical Connection

#### Terminals and indicators

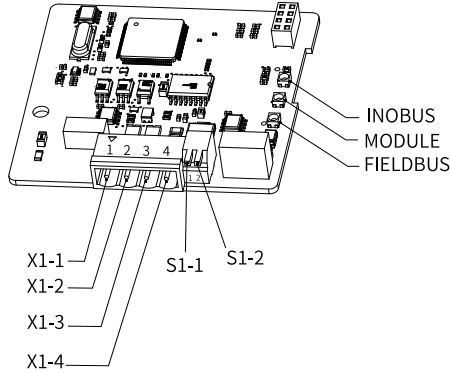

Figure 3-25 External connection diagram of MD580-SI-CAN1 module

Table 3-14 Terminal description

Terminal Pin	Name	Wiring	Description
X1-1	PE	For connection to the shield	Recommended cable: four-conductor shielded twisted pair cable Cross-sectional area: 0.3 mm <sup>2</sup> to 2.0 mm <sup>2</sup>
X1-2	CANH	Twisted pair	
X1-3	CANL		
X1-4	CGND	Connection is recommended	
S1-1	DIP switch 1	/	Termination resistor selection
S1-2	DIP switch 2	/	Valid when S1-1 and S1-2 are all set to ON

The following figure shows the terminal wiring.

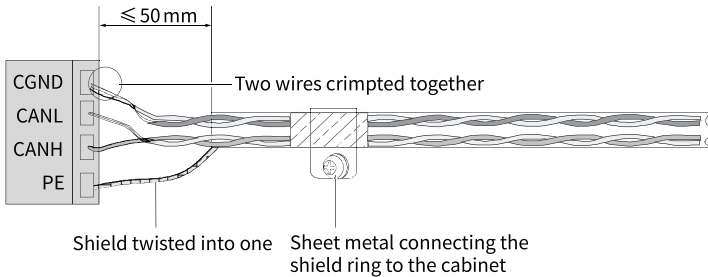

Figure 3-26 Terminal wiring

## Bus topology

The CAN bus supports a maximum of 63 nodes (excluding the master). The following figure shows the networking. Set the termination resistors of the master and the last node to ON.

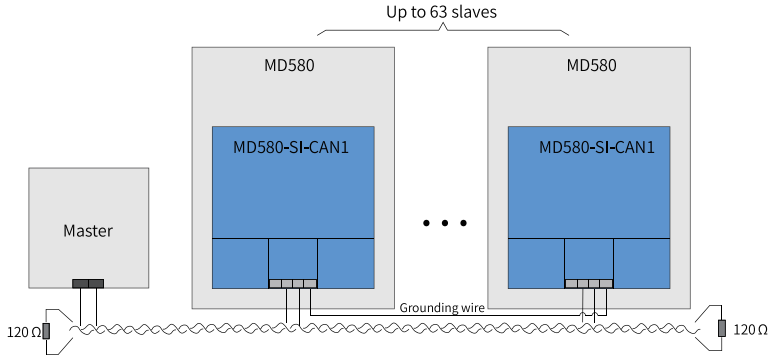

Figure 3-27 Networking diagram

## Bus transmission distance

The transmission distance of CAN bus is directly dependent on the baud rate and communication cable. The following table shows the mapping between the maximum transmission distance of CAN bus and the baud rate.

No.	Transmission Distance	Rate	Number of Nodes	Cable Diameter
1	25 m	1 Mbps	64	0.34 mm <sup>2</sup>
2	95 m	500 kbps	64	0.34 mm <sup>2</sup>
3	560 m	100 kbps	64	0.50 mm <sup>2</sup>
4	1100 m	50 kbps	64	0.75 mm <sup>2</sup>

## 3.5.2 Modbus RTU Communication

### 3.5.2.1 Overview

Features of the fieldbus adaption module MD580-SI-RS1:

- MD580-SI-RS1 is a new-generation fieldbus adaption module of Inovance. It is used together with the MD580 to realize networking and remote control of the multi-drive system through the Modbus RTU communication network.
- MD580-SI-RS1 features good compatibility. It can be used with different series of MD580 AC drives, and is compatible with MD880 series products.

### 3.5.2.2 Electrical Connection

#### Terminals and indicators

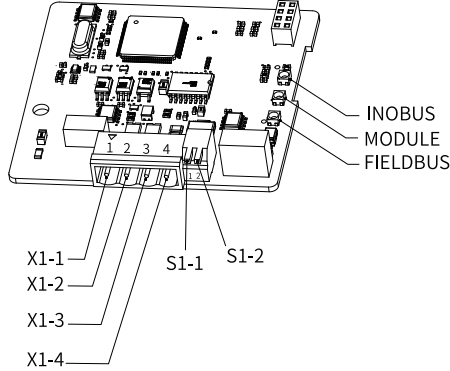

Figure 3-28 External connection diagram of MD580-SI-RS1 module

Table 3-15 Terminal description

Terminal Pin	Name	Wiring	Description
X1-1	SHIELD	For connection to the shield	Recommended cable: four-conductor shielded twisted pair cable Cross-sectional area: 0.3 mm <sup>2</sup> to 2.0 mm <sup>2</sup>
X1-2	485+	Twisted pair	
X1-3	485-		
X1-4	GND	Connection is recommended	
S1-1	DIP switch 1	-	Termination resistor selection
S1-2	DIP switch 2	-	Valid when S1-1 and S1-2 are all set to ON

The following figure shows the terminal wiring.

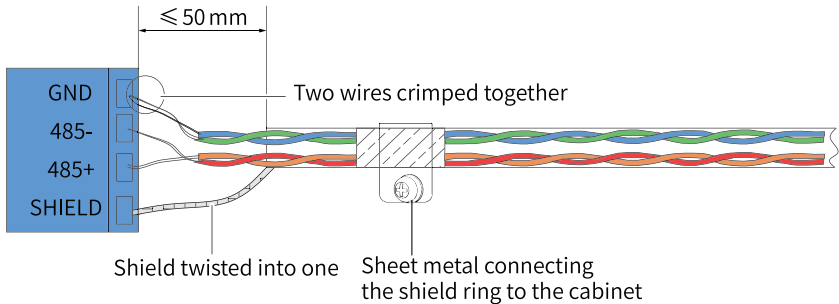
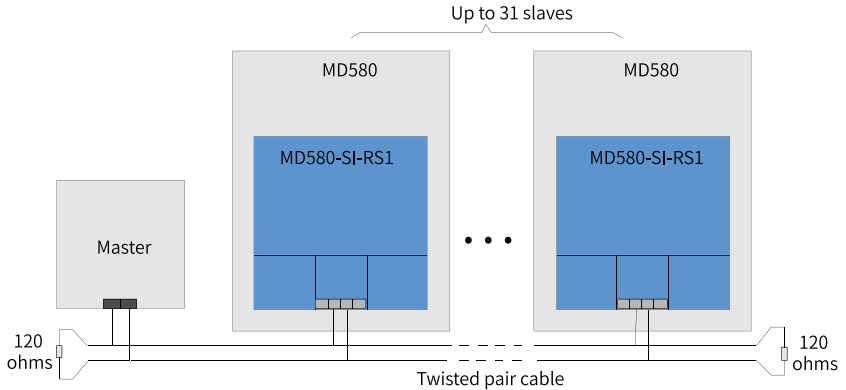

Figure 3-29 Terminal wiring

## Bus topology

The Modbus RTU bus supports a maximum of 31 nodes (excluding the master). Set the termination resistors of the master and the last node to ON. The following figure shows the networking. If the number of nodes for networking exceeds 31, use a repeater.



## 3.5.3 PROFIBUS DP Communication

### 3.5.3.1 Overview

MD580–SI-DP1, a PROFIBUS-DP fieldbus adapter module, must be used with the MD580 AC drive of Inovance and fixed in the extension slot (CN13 slot) of the AC drive. It communicates with the bus master using the PROFIBUS-DP communication protocol.

Features:

- Automatically identifies the bus baud rate; supports the communication rate ranges of 9.6 kbps to 12 Mbps.
- In the bus topology, connects up to 32 nodes (including the master) when no repeater is used, or up to 122 nodes when repeaters are used (each segment comprising 31 nodes and one repeater).
- Complies with the EMS standard EN 61800-3:2004.
- Supports DPV0 and DPV1 for data exchange with the master.
- Be powered by the AC drive, without requiring an external power supply.

### 3.5.3.2 Electrical Connection

#### Bus cable description

The following table describes the dedicated cable for the PROFIBUS DP bus.

Table 3-16 Cable specifications

Parameter	Description
Conductor	One pair (2 x 22AWG) of single-strand copper conductors
Insulating sheath color	Green, red
Shield	Aluminum plastic tape + tinned copper braid
Sheath material	PVC
Operating temperature	-30°C to +70°C
Appearance	Purple

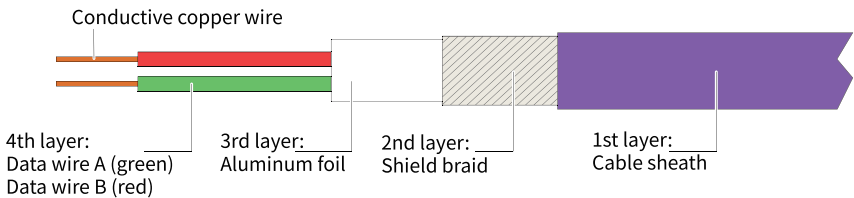

Figure 3-30 Internal layer of the bus

**Bus terminal**

Siemens dedicated PROFIBUS DP connector 6ES7 972-0BB12-0XA0 is recommended.

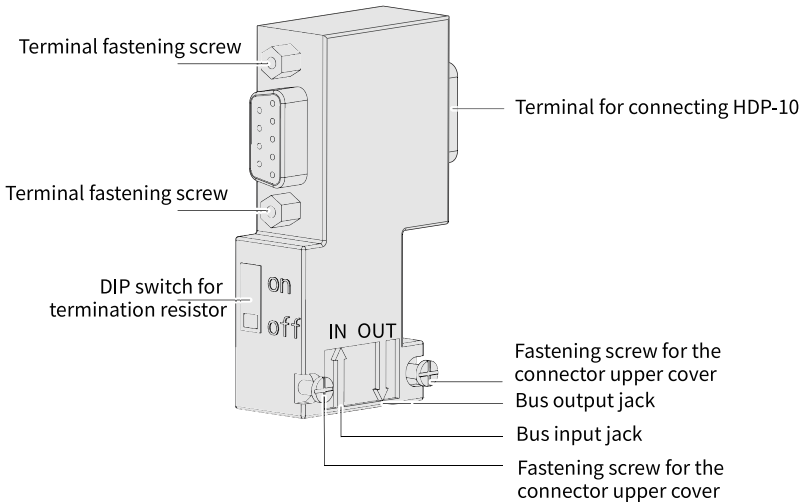

Figure 3-31 Bus connector

**Bus connection procedure**

1. Strip the cable sheath and reverse the length as specified in the following figure.

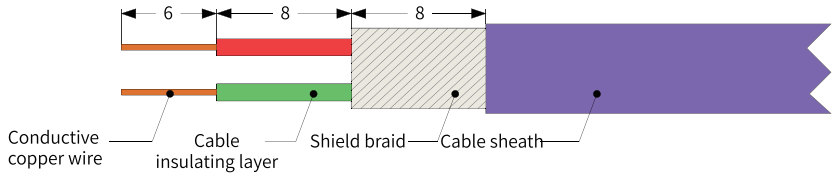
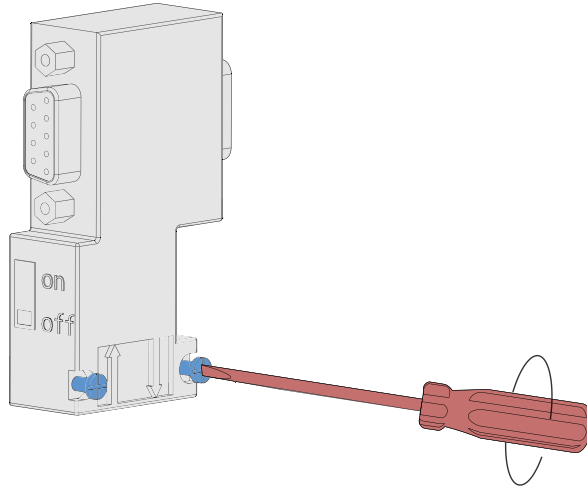
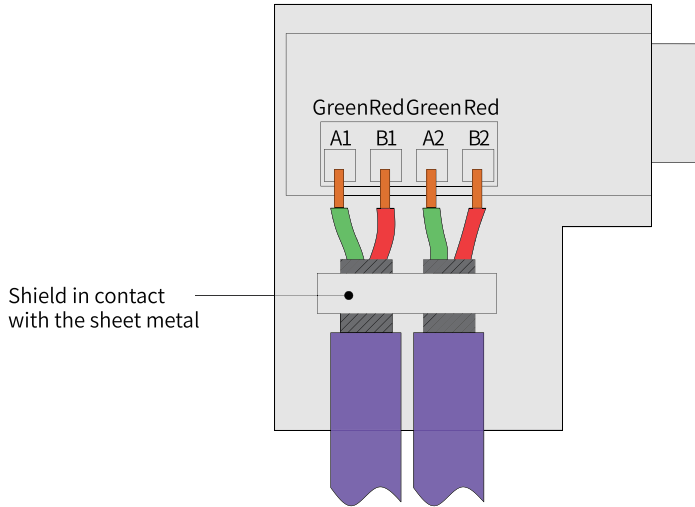

Figure 3-32 Length of each layer of the bus cable (unit: mm)

2. Open the bus connector terminal cover using the 1# straight screwdriver.



3. Secure the cable to the connector installation position using the 1# straight screwdriver. Ensure that the shield is in close contact with the shield metal sheet. Connect the green cable to the A terminal and the red cable to the B terminal, as shown in the following figure.



4. After you close the connector cover and tighten the screws on the cover, insert the connector to the DB9 port of the MD580-SI-DP1 module, and use a screwdriver to tighten the screws on both sides.

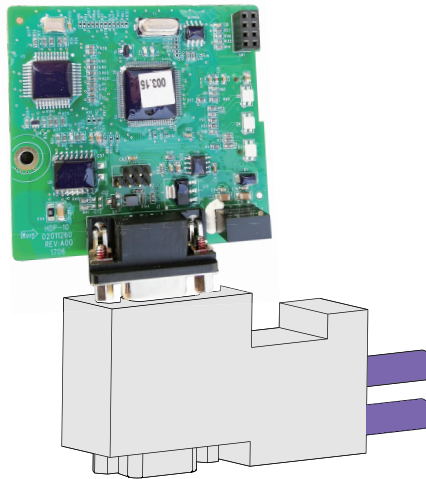

---

### **Note**

When installing the PROFIBUS DP bus, ensure that the studs on both sides of the Siemens terminals are securely connected to the MD580-SI-DP1 module. Otherwise, the communication may fail or the communication quality may deteriorate.

---

## Bus topology

- For multi-drive system connection without any repeater, connect termination resistors to the first and last AC drives, as shown in *"Figure 3-33 Multi-drive system connection without any repeater" on page 91.*

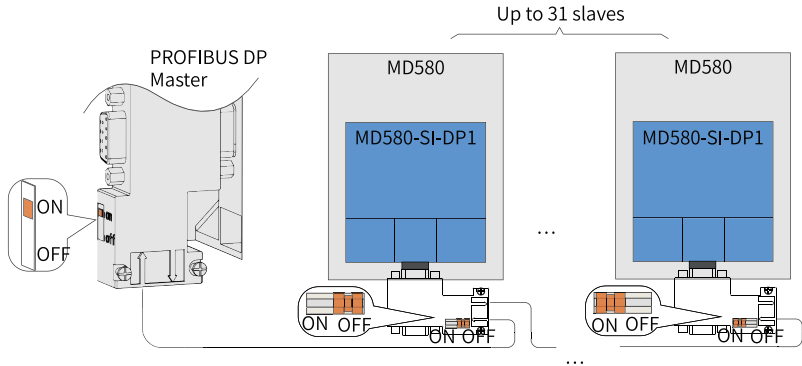

Figure 3-33 Multi-drive system connection without any repeater

- For multi-drive system connection with repeaters, connect termination resistors to the first and last AC drives, and connect the termination resistor of the repeater, as shown in *"Figure 3-34 Multi-drive system connection with repeaters" on page 92.*

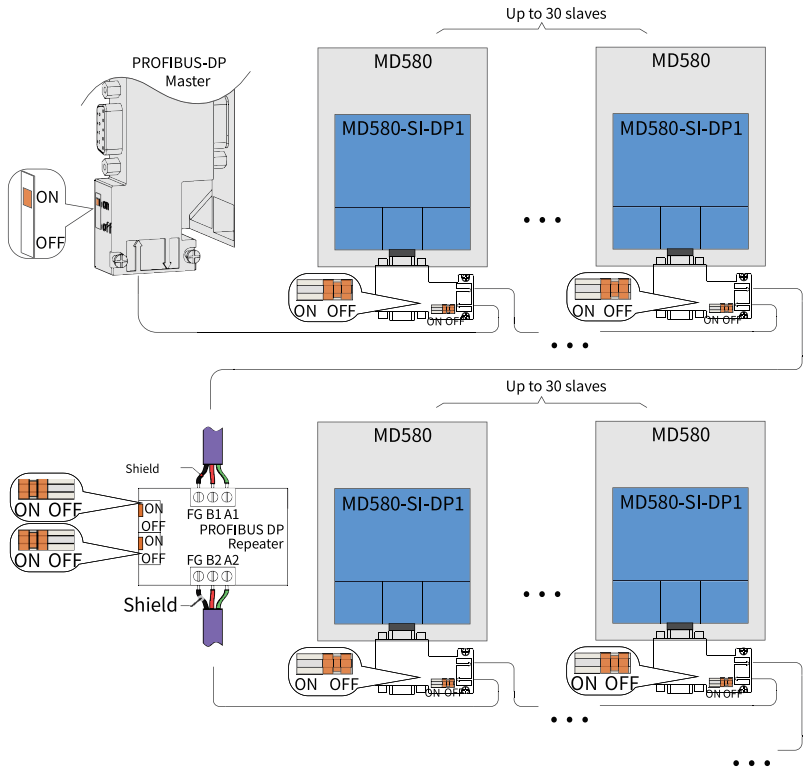

Figure 3-34 Multi-drive system connection with repeaters

**Baud rate and communication distance**

Baud Rate (kbps)	9.6	19.2	93.75	187.5	500	1500	3000	12000
Transmission Distance (m)	1200	1200	1200	1200	400	200	100	100

**Note**

The transmission distances in the preceding table are distances without using any repeater.

## 3.5.4 PROFINET IO Industrial Ethernet Communication

### 3.5.4.1 Overview

The PROFINET I/O Industrial Ethernet adapter module (MD580-SI-PN1 for short) meets international PROFINET I/O Industrial Ethernet standards. The module is used on the MD580 series AC drive, so that the AC drive can work as a slave on the PROFINET I/O Industrial Ethernet and be controlled by a PROFINET I/O Industrial Ethernet master. This effectively improves system communication efficiency and enriches the networking functions of the MD580 series AC drive.

Features:

- Supports up to 100 Mbit/s bus communication rate. The communication period is short.
- Provides flexible networking and supports almost all types of topologies: chain, bus, tree, and star.
- Uses a distributed clock and exchanges data using a pure-hardware mechanism, effectively the timing accuracy of data exchange.
- Supports direct installation in the extension slot of the MD580 AC drive without requiring an external power supply, which is convenient.

### 3.5.4.2 Electrical Connection

The MD580-SI-PN1 uses a standard Ethernet RJ45 socket for connection to a PROFINET master. The pin signal definitions are the same as those of the standard Ethernet pins. It supports both crossover and straight-through cabling modes.

### Electrical connection for chain networking

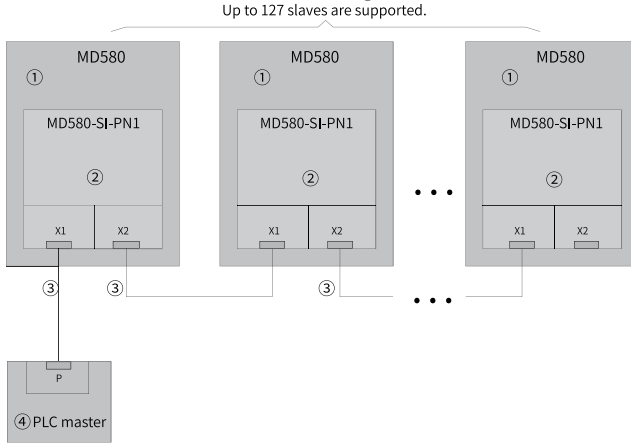

Figure 3-35 Electrical connection diagram for chain networking

No.	Name
①	MD580 AC drive
②	MD580-SI-PN1 Industrial Ethernet module
③	Network cable
④	PLC master



effectively improves system communication efficiency and enriches the networking functions of the MD580 series AC drive.

Features:

- Supports switch networking.
- Does not support IP address allocation using DPCH.
- Supports the minimum HMBT communication period of 6 ms.
- Supports reading of up to 124 parameters per time.
- Supports connection of up to two Modbus TCP clients. The minimum communication period is doubled to 12ms when two clients are connected.
- Supports up to 100 m node-to-node transmission distance.

### 3.5.5.2 Electrical Connection

The MD580-SI-EM1 uses a standard Ethernet RJ45 socket for connection to the PC background. The pin signal definitions are the same as those of the standard Ethernet pins. It supports both crossover and straight-through cabling modes.

#### Single-module electrical connection

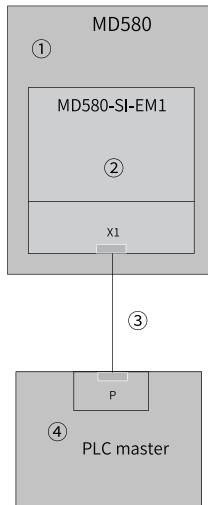

Figure 3-37 Single-module electrical connection diagram

No.	Name
①	MD580 AC drive
②	MD580-SI-EM1 Industrial Ethernet module
③	Network cable
④	PC master

## Multi-module electrical connection

Up to 253 slaves are supported.

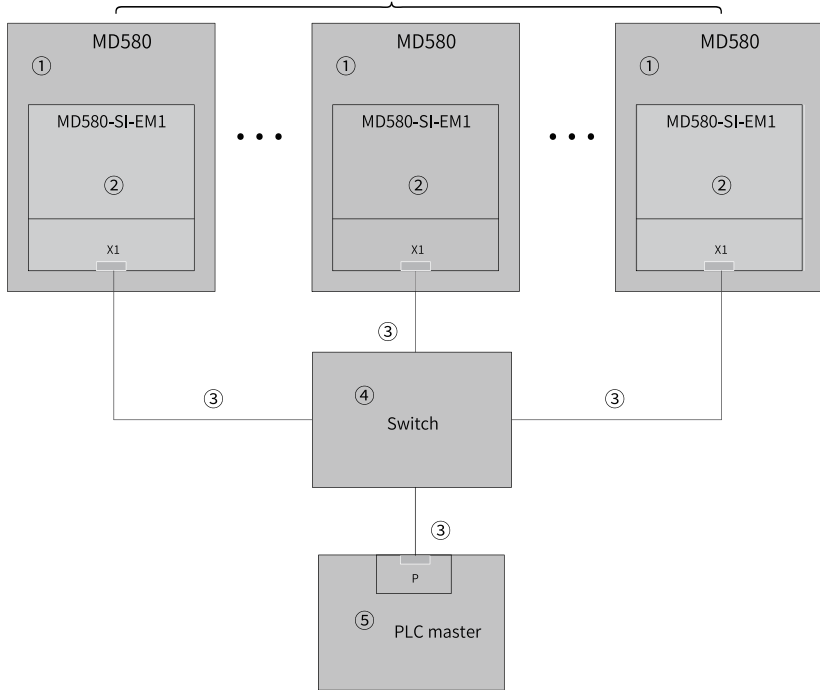

Figure 3-38 Multi-module electrical connection diagram

No.	Name
①	MD580 AC drive
②	MD580-SI-EM1 Industrial Ethernet module
③	Network cable
④	Switch
⑤	PC master

## 3.5.6 EtherNet/IP Industrial Ethernet Communication

### 3.5.6.1 Overview

The EtherNet/IP module (hereinafter referred to as MD580-SI-EN1) conforms to the Ethernet industrial protocol bus standard. It features high efficiency, flexible topology, and easy operation. When the MD580 is used together with the MD580-SI-EN1, the MD580 can serve as the EtherNet/IP adapter to be controlled by the EtherNet/IP scanner. This improves the communication efficiency and enriches the networking functions of the MD580.

Features:

- It supports various types of topology structures with the switch.
- It supports full duplex networks with the bandwidth of 100 MHz.
- It can be used together with the InoDriveStudio to implement commissioning functions.
- It is powered by the MD580 without external power supply required.
- A minimum of communication cycle of 1 ms is supported.

**3.5.6.2 Electrical Connection**

Ethernet/IP supports various topology structures, including bus, star, and tree types. Diversified networking modes can be implemented by using switches.

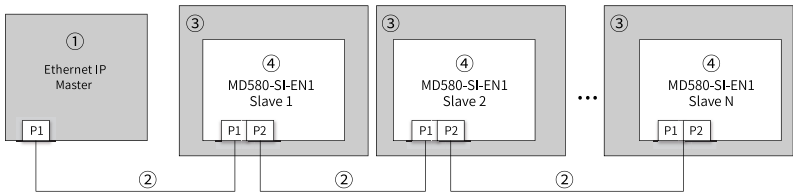

Figure 3-39 Bus topology

No.	Name
①	Ethernet/IP master
②	Network cable (It is recommended to use shielded twisted pair Cat 5e Ethernet cable, and the registered jack used for crimping must have a metal shell for earth shield protection.)
③	MD580 AC drive
④	MD580-SI-EN1 communication expansion card

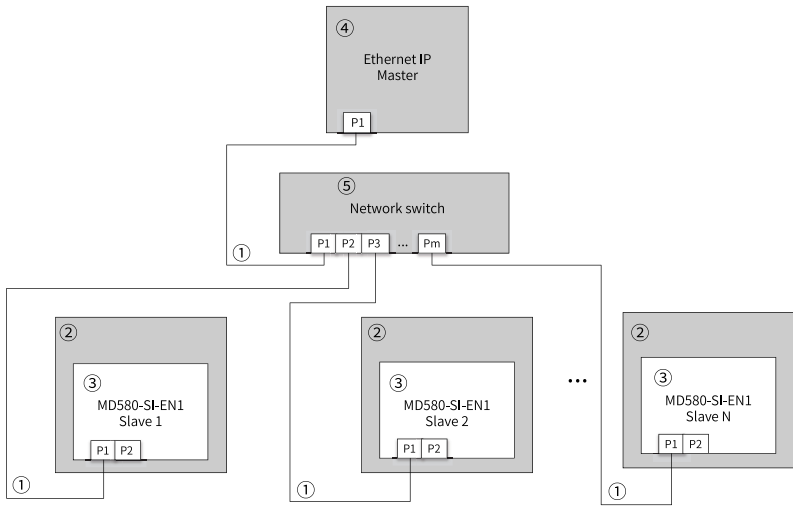

Figure 3-40 Star-type topology

No.	Name
①	Network cable (It is recommended to use shielded twisted pair Cat 5e Ethernet cable, and the registered jack used for crimping must have a metal shell for earth shield protection.)
②	MD580 AC drive
③	MD580-SI-EN1 communication expansion card
④	Ethernet/IP master
⑤	Switch

## 3.5.7 EtherCAT Industrial Ethernet Communication

### 3.5.7.1 Overview

The MD580-SI-EtherCAT industrial Ethernet bus module conforms to common EtherCAT industrial Ethernet standards. The module is mainly used together with the MD580 series AC drive. With the module, the MD580 can serve as the EtherCAT slave station and can be controlled by the EtherCAT master station. This effectively improves the communication efficiency and enriches the networking function of the MD580.

Features:

- It passes the Conformance Test Tool (CTT) test.
- It supports up to 16 RXPDOs and 16 TXPDOs, and supports dynamic configuration of PDOs.

- The DC synchronous clock mode is supported.
- The CoE protocol (PDO+SDO) is supported.
- A minimum of communication cycle of 125 us is supported.
- It supports various topology structures, including chain, bus, tree, and star types.
- The module is installed in the slot of the communication expansion card (CN13) without the external power supply.

### 3.5.7.2 Electrical Connection

EtherCAT supports various topology structures, including chain, bus, tree, and star types. This section describes the chain and star types.

#### Chain networking

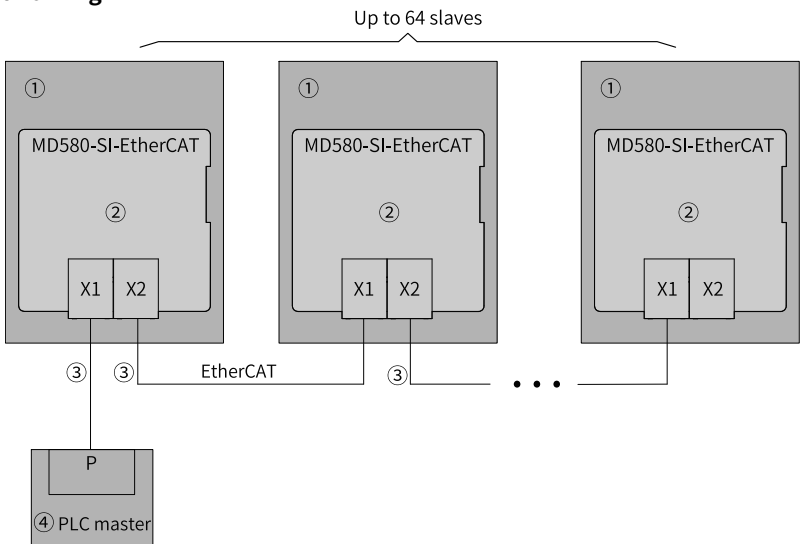

Figure 3-41 Chain networking topology

Table 3-17 Description of chain networking topology

No.	Name
①	MD580 AC drive
②	MD580-SI-EtherCAT industrial Ethernet module
③	Network cable (It is recommended to use shielded Cat 5e Ethernet cable, and the registered jack used for crimping must have a metal shell for earth screen protection.)
④	PLC master

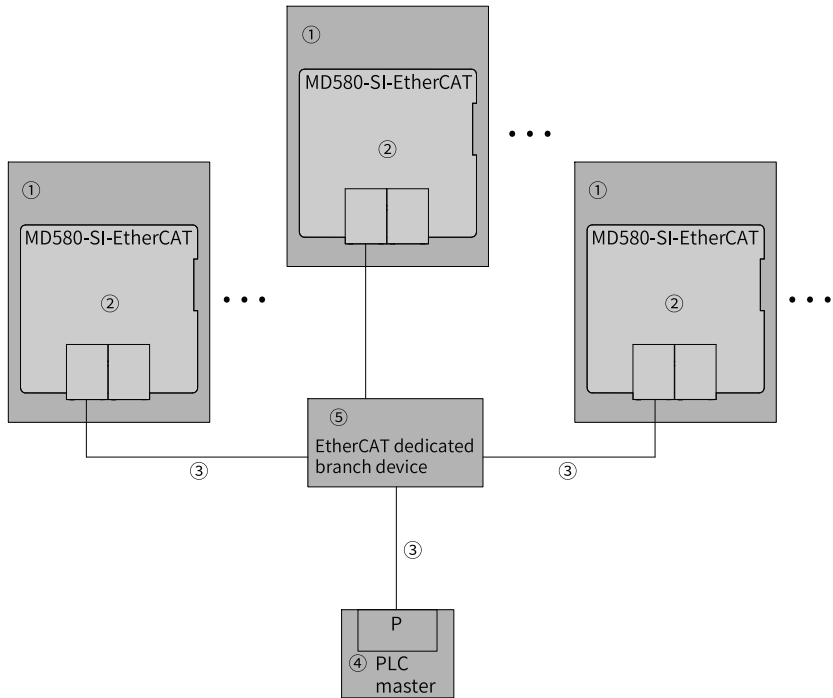

Figure 3-42 Chain networking topology

Table 3-18 Description of star networking topology

No.	Name
①	MD580 AC drive
②	MD580-SI-EtherCAT industrial Ethernet module
③	Network cable (It is recommended to use shielded Cat 5e Ethernet cable, and the registered jack used for crimping must have a metal shell for earth screen protection.)
④	PLC master
⑤	EtherCAT dedicated branch device

## 3.6 Grounding

### 3.6.1 Main Circuit

To correctly ground the AC drive, observe the following requirements:



- Ground the grounding terminal to avoid electric shock. Comply with the relevant local electrical regulations for grounding.
  - To prevent electric shocks, check that the protective grounding conductor meets the technical specifications and local safety standards, and use a shortest possible grounding cable. The leakage current of the AC drive can be over 3.5 mA. Use a copper wire with a cross-sectional area of at least 10 mm<sup>2</sup> for the protective grounding, or use two protective grounding conductors of the same specifications for connection according to EN 61800-5-1.
  - Follow the instructions for grounding every AC drive when multiple AC drives are installed. Incorrect grounding may lead to malfunction of AC drives.
  - Disconnect the optional grounding screw of VDR (available on the AC drive) before the voltage resistance test. Failure to comply may fail the test.
- 
- Use a proper yellow-green copper cable as the protective grounding conductor, and avoid connecting it to switchgears such as circuit breakers in series.
  - Reliably ground the grounding terminal. Failure to comply may result in abnormal operation of the AC drive and even damage.
  - Avoid connecting the grounding (PE) terminal to the N terminal of the neutral wire of the power supply.
  - Mount the equipment onto a conductive metal surface (recommended) to ensure well connection between the entire conductive bottom of the equipment and the mounting surface.
  - Fasten the grounding screws using the recommended tightening torque to avoid loose or excessively tight protective grounding conductor.

### 3.6.2 Grounding the Control Board

The control board is grounded by default. The following figure shows the grounding screw position.

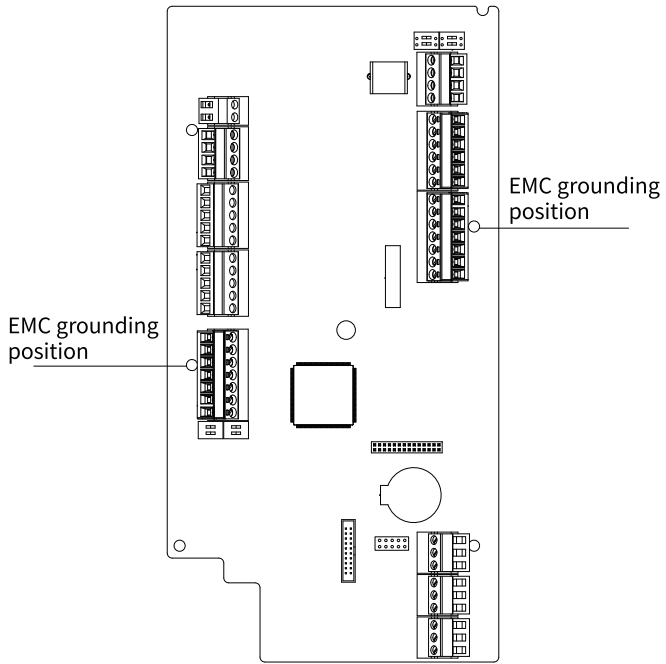

Figure 3-43 Control board grounding

### 3.6.3 Grounding a Single Device

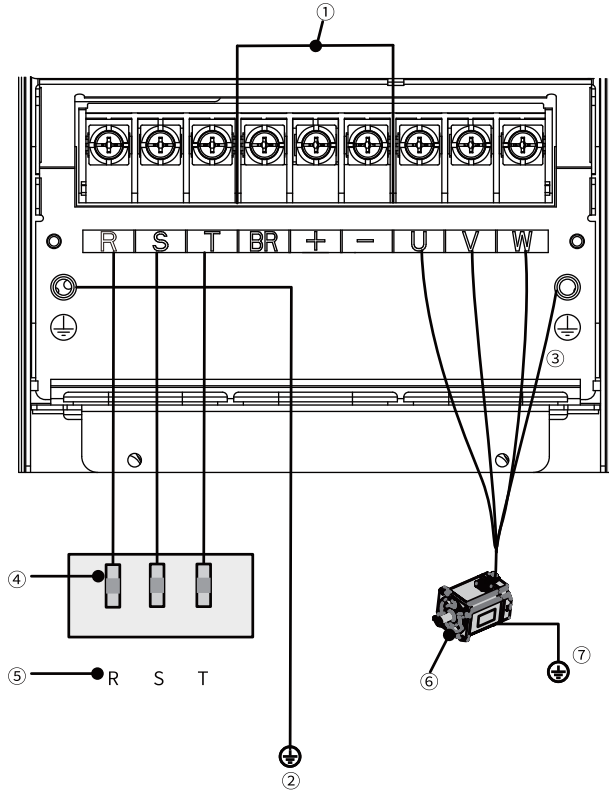

Figure 3-44 Main circuit grounding

Table 3-19 Description of the grounding of the main circuit

No.	Description
①	Avoid grounding the DC bus terminal and braking resistor terminal.
②	Connect the PE terminal on the input power supply side to the PE terminal on the input side of the AC drive.
③	Connect the PE terminal on the output side of the AC drive to the motor output cable shield.
④	Input protection (fuse with its lower part connected to the filter)
⑤	Power supply
⑥	Three-phase motor
⑦	Ground the motor enclosure.

## Note

Arrangement of the main circuit terminals varies with models.

### 3.6.4 Multiple AC Drives

The following figure shows the grounding when multiple AC drives are installed in the cabinet side by side.

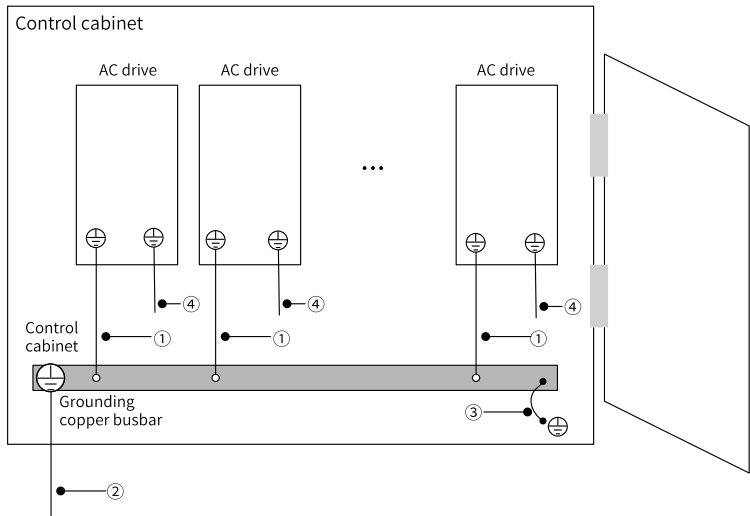

Figure 3-45 Grounding multiple AC drives installed side by side

Table 3-20 Grounding multiple AC drives installed side by side

No.	Wiring Description
①	Connect the PE terminal on the input side of the main circuit to the grounding copper busbar of the control cabinet through a protective grounding conductor.
②	Connect the PE terminal on the power supply side to the grounding copper busbar of the control cabinet.
③	Connect the grounding copper busbar of the control cabinet to the metal housing through a protective grounding conductor.
④	Connect the motor output cable shield to the PE terminal on the output side of the product.

### 3.6.5 Grounding the Cabinet System

The cost-effective method of suppressing interference in a cabinet is to isolate the interference source from the equipment that may be interfered with. Divide a cabinet into multiple EMC compartments or use multiple cabinets based on the intensity of interference sources, and install each device in accordance with the following wiring principles.

Table 3-21 Wiring requirements

No.	Wiring Requirement
1	Install the control devices and the drive devices in two different cabinets.
2	Use grounding cables with a cross-sectional area of at least 16 mm <sup>2</sup> to connect different cabinets, therefore realizing equipotential between the cabinets.
3	Place the devices in different areas in the cabinet according to the device signal strength.
4	Carry out equipotential bonding for the devices in different areas of the cabinet.
5	Shield all communication (such as RS-485) signal cables leading from the cabinet.
6	Install the power input filter close to the cabinet input interface.
7	Spray each grounding point in the cabinet.

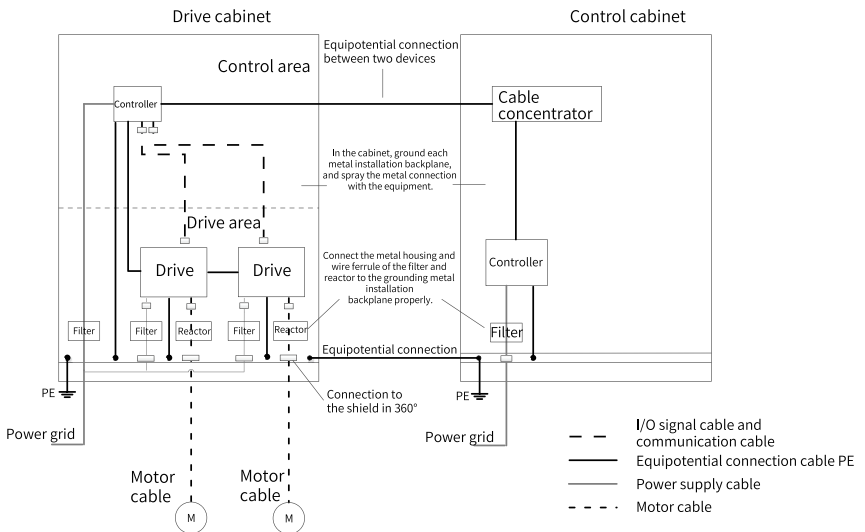
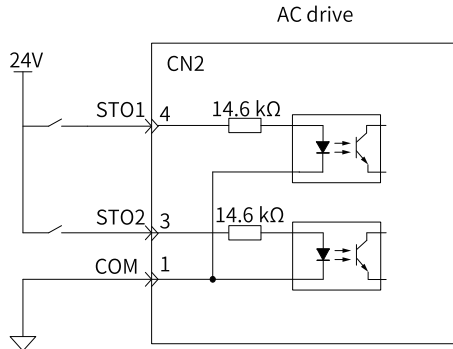

Figure 3-46 Recommended wiring for the cabinet system

### 3.7 STO Safety Design and Wiring

#### 1. Example of external 24 V connection



#### 2. Example of internal 24 V connection

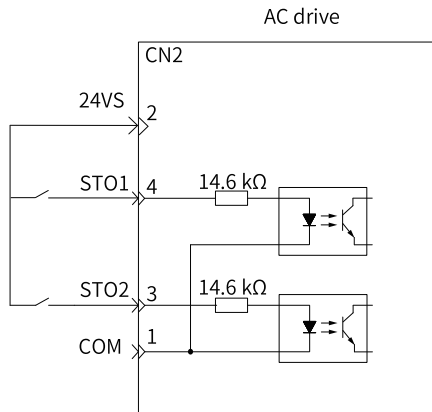

## **4 Option Selection**

### **4.1 Option List**

Peripheral accessories include braking units, function expansion cards, and external operating panels, as shown in the following table. For use of each accessory, see the corresponding user guide. If any option is required, specify it in your order.

Table 4-1 List of options for the AC drive

Option Name		Option Model	Supported AC Drive Model	Description
Braking components	Built-in braking unit	Models containing letter "B"	-	Standard for 0.4G/0.75P to 15G/18.5P models and optional for 18.5G/22P to 75G/90P models
	External braking unit	MDBUN-60-T	For 90G/110P models and above, multiple external braking units are connected in parallel.	External braking unit for 90G/110P models and above
		MDBUN-60-5T		
		MDBUN-90-T		
		MDBUN-90-5T		
		MDBUN-200-T		
MDBUN-200-5T				

Option Name		Option Model	Supported AC Drive Model	Description
Expansion card	CANopen communication card	MD580-SI-CAN1	Available for all models	CANopen bus adaption
	Modbus RTU communication card	MD580-SI-RS1	Available for all models	Modbus RTU bus adaption
	PROFIBUS DP communication card	MD580-SI-DP1	Available for all models	PROFIBUS DP bus adaption
	PROFINET IO communication card	MD580-SI-PN1	Available for all models	PROFINET IO industrial Ethernet
	Modbus TCP communication card	MD580-SI-EM1	Available for all models	Modbus TCP industrial Ethernet
	EtherCAT communication card	MD580-SI-ECAT1	Available for all models	EtherCAT communication
	EtherNet/IP communication card	MD580-SI-EN1	Available for all models	EtherNet/IP communication card
	Safe motor temperature detection card	MD580-HSMT-ATEX1	Applicable to T1-T3 models	When the PTC in the motor is overheated, the detection card will disable the DO and activate the STO.
		HSMT-10	Applicable to T4-T12 models	
	I/O expansion card	MD580-IO-RD1	Available for all models	It provides two AIs, two AOs, four DIs, and two ROs.
	ABZ and SSI dual-encoder card	MD580-PG-AU1	Available for all models	Supports full closed-loop control; supports TTL level ABZ encoder and SSI encoder; provides the DB15 interface.
	Sin-cos and SSI dual encoder detection module	MD580-PG-AR1	Available for all models	Supports full closed-loop control; supports $\pm 1$ Vpp sin-cos encoder and SSI encoder; provides the DB15 interface.
	Resolver interface card	MD38PG4	Available for all models	Applicable to the resolver with the excitation frequency of 10 kHz and with the DB9 interface
MD38PGMD multi-function encoder card	MD38PGMD	Available for all models	The MD38PGMD card supports differential input, collector input, push-pull input, as well as differential output and collector output; therefore, it can be used to connect to different encoders and supports A/B phase input of the host controller.	

Option Name		Option Model	Supported AC Drive Model	Description
Cables	LED operating panel	MDKE-10	Available for all models	Connected through the RJ45 interface
	External LCD operating panel	SOP-20-880	Available for all models	Supports parameter copy and download
	SOP-20-880 mounting base	CP600-BASE1	Available for all models	The SOP-20-880 can be installed to the cabinet door by using the mounting base.
	MDKE-10 mounting base	MD580-AZJ1	Available for all models	The MDKE-10 can be installed to the cabinet door by using the mounting base.
	Extension cable	MDCAB	Available for all models	Standard 8-conductor network cable in the length of three meters, which can be connected to the LED/LCD operating panel
	Main circuit cable	Lugs manufactured by Suzhou Yuanli are recommended. For details of recommended lugs, see <a href="#">"3.3.2 Cable Selection" on page 60.</a>		It is recommended that the input and output main circuit cables use symmetrical shielded cables. Compared with four-conductor cables, symmetrical shielded cables can reduce electromagnetic radiation in the whole transmission system. It is recommended that power cables also use symmetrical shielded cables.
	Control circuit cables	All control circuit cables must be shielded cables. Use a separate shielded cable for each type of analog signal. It is recommended that digital signal cables use shielded twisted pair (STP) cables.		

Option Name		Option Model	Supported AC Drive Model	Description
Mounting accessories	Mounting rail	MD500-AZJ-A3T10	Optional (T10 to T12 models)	Used for installing the AC drive to the cabinet
	Grounding bracket of the control cable shield	MD580-AZJ-A3T1	Optional (T1 to T9 models)	The accessory is used for re-fixing the control cable and stable grounding of the shield in 360°. It applies only to T1 to T9 models.
		MD580-AZJ-A3T2		
		MD580-AZJ-A3T3		
		MD580-AZJ-A3T4		
		MD580-AZJ-A3T5		
		MD580-AZJ-A3T6		
		MD580-AZJ-A3T7		
		MD580-AZJ-A3T8		
	MD580-AZJ-A3T9			
	Grounding bracket of the power cable shield	MD580-AZJ-A1T1	Optional (T1 to T9 models)	The accessory is used for re-fixing the power cable and stable grounding of the shield in 360°. It applies only to T1 to T9 models.
		MD580-AZJ-A1T2		
		MD580-AZJ-A1T3		
		MD580-AZJ-A1T4		
		MD580-AZJ-A1T5		
		MD580-AZJ-A1T6		
		MD580-AZJ-A1T7		
		MD580-AZJ-A1T8		
	MD580-AZJ-A1T9			
	U/V/W output copper busbar	MD500-TP-T10	T10	MD580 models excluding that with the base (-L) are delivered with the U/V/W output copper busbar.
		MD500-TP-T11	T11	
MD500-TP-T12		T12		
Through-hole mounting bracket	MD580-AZJ-A2T1	Optional (T1 to T9 models)	The bracket is used for through-hole mounting. It applies only to T1 to T9 models.	
	MD580-AZJ-A2T2			
	MD580-AZJ-A2T3			
	MD580-AZJ-A2T4			
	MD580-AZJ-A2T5			
	MD580-AZJ-A2T6			
Mounting accessories	Through-hole mounting bracket	MD580-AZJ-A2T7	Optional (T1 to T9 models)	The bracket is used for through-hole mounting. It applies only to T1 to T9 models.
		MD580-AZJ-A2T8		
		MD580-AZJ-A2T9		
	MDKE10 bracket	MD580-AZJ1	Optional (applicable to all models)	The accessory can be used to install the operating panel to the cabinet. It is applicable to all models.
	SOP-20-880 bracket	CP600-BASE1	Optional (applicable to all models)	The accessory can be used to install the LCD operating panel. It is applicable to all models.

## 4.2 Mounting Accessories

### 4.2.1 Bottom Mounting Bracket

T10 to T12 models come with a bottom mounting bracket. When the AC drive is installed in a cabinet, the bottom mounting bracket is required for fixing the AC drive to the cabinet rack base. The dimensions of bottom mounting bracket vary with the power rating, weight, and size of the AC drive, as shown in the following figures.

The bracket delivered with the AC drive is applicable to cabinets 600 mm in depth. If you need a bracket for a cabinet 800 mm in depth, contact Inovance.

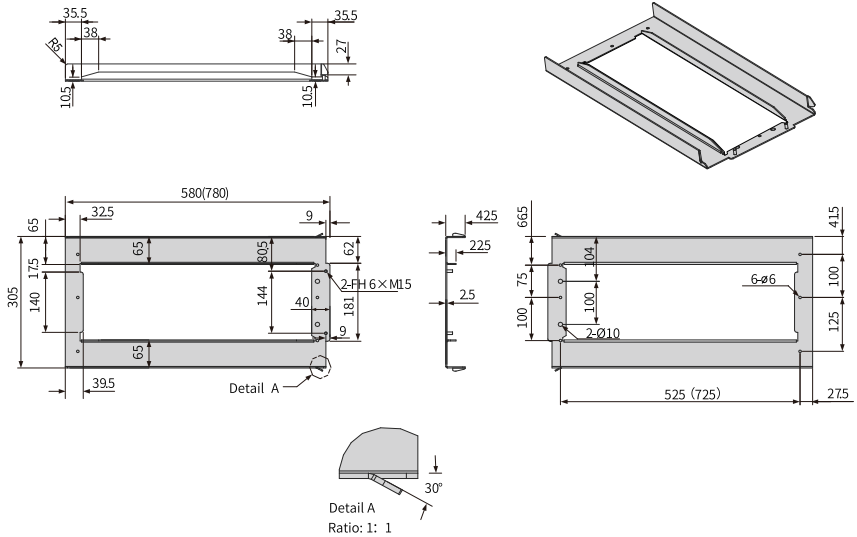
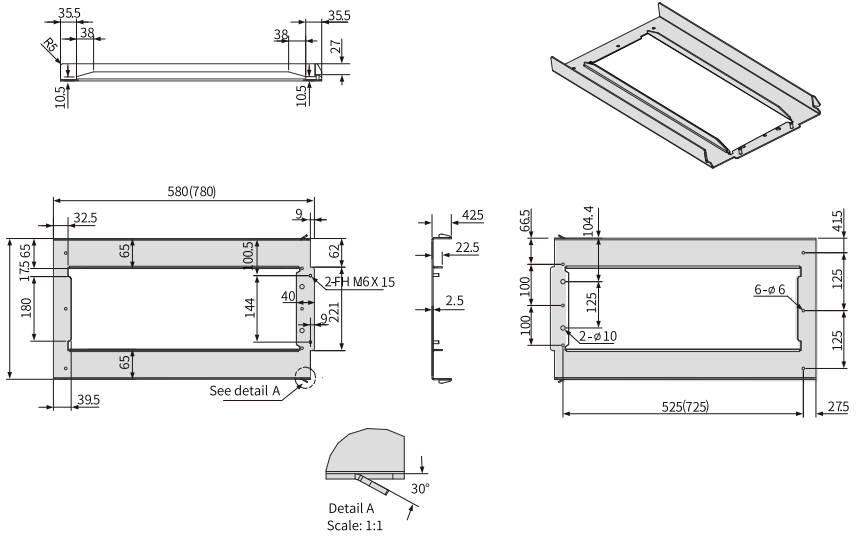
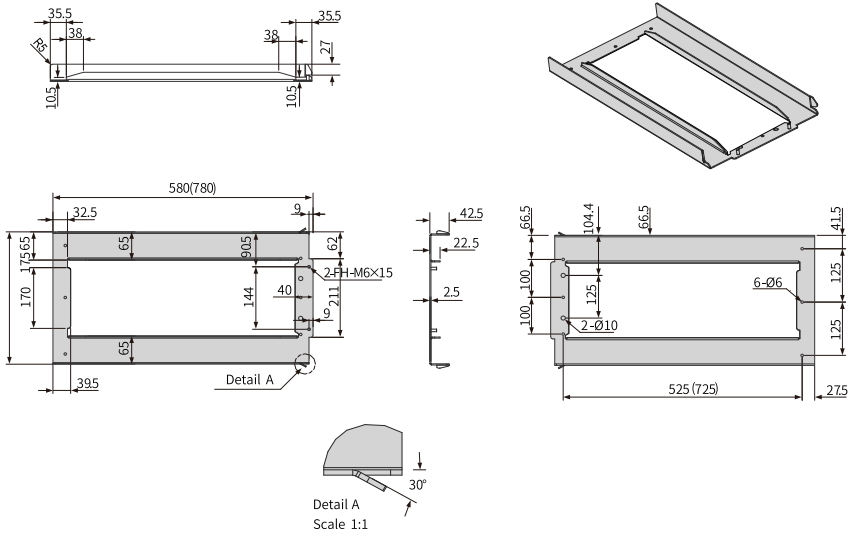

Figure 4-1 Dimensions of bottom mounting bracket for T10 models



---

## Note

- The bottom mounting brackets shown in the preceding figures are applicable to PS standard cabinets, sized either 800 mm (W) x 600 mm (D) or 800 mm (W) x 800 mm (D). Dimensions in parentheses are applicable to PS standard cabinets sized 800 mm (W) x 800 mm (D).
  - Bottom mounting brackets delivered with T10 to T12 models are only applicable to PS standard cabinets sized 800 mm (W) x 600 mm (D). For PS standard cabinets sized 800 mm (W) x 800 mm (D), contact Inovance.
- 

### 4.2.2 Guide Rails

For details of the guide rails, see *Operation Instructions for MD500-AZJ-A3T10 Guide Rail*.

### 4.2.3 U/V/W Output Sid Copper Busbars

All MD580 models excluding those with the base (-L) are delivered with U/V/W output side copper busbars. To install the U/V/W output copper busbars, follow the steps below:

1. Use the screwdriver or cutting pliers to remove the three knockouts.

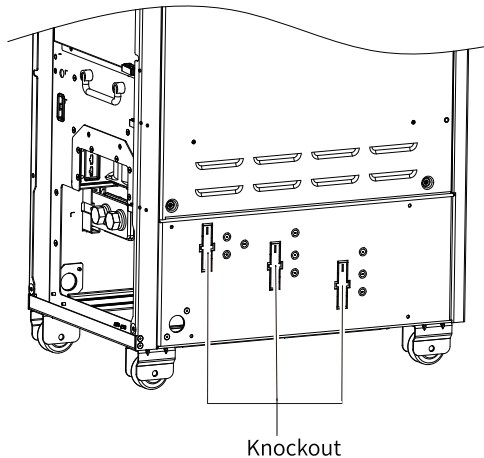

2. Use the four plastic snap-fit joints in the packing box to fasten the insulating paper to the chassis through the four holes on the paper.

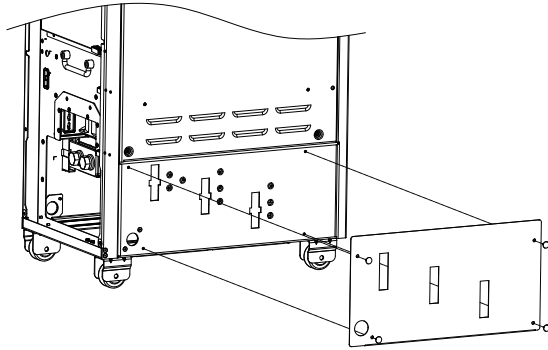

3. Remove the six screws on the drive, install the copper busbars, and then fasten the six screws.

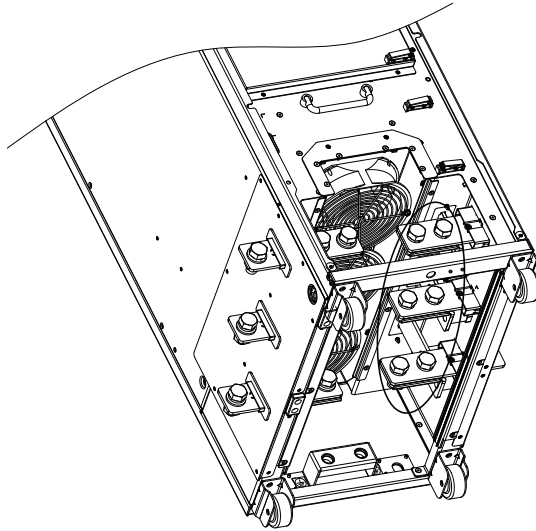

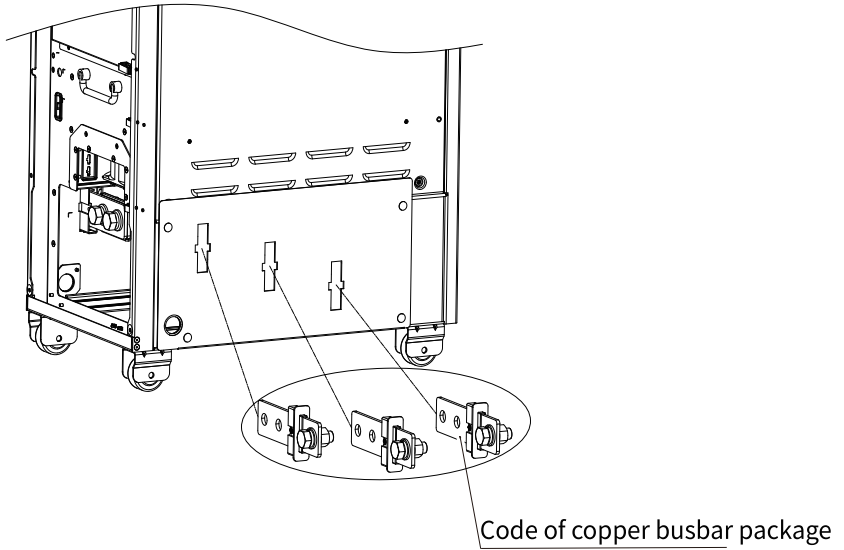

The following figures shows the installed copper busbar.

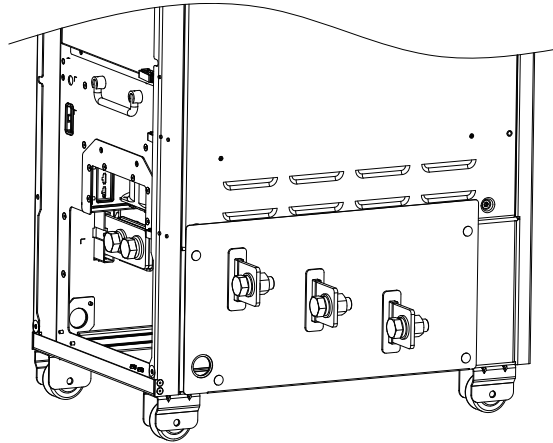

#### 4.2.4 Through-hole Mounting Bracket

The through-hole mounting bracket is optional and needs to be purchased as required.

**Applicable models**

Table 4-2 Models of through-hole mounting brackets

Model of Through-hole Mounting Brackets	Structure
MD580-AZJ-A2T1	T1
MD580-AZJ-A2T2	T2
MD580-AZJ-A2T3	T3
MD580-AZJ-A2T4	T4
MD580-AZJ-A2T5	T5
MD580-AZJ-A2T6	T6
MD580-AZJ-A2T7	T7
MD580-AZJ-A2T8	T8
MD580-AZJ-A2T9	T9

## Mounting-hole dimensions

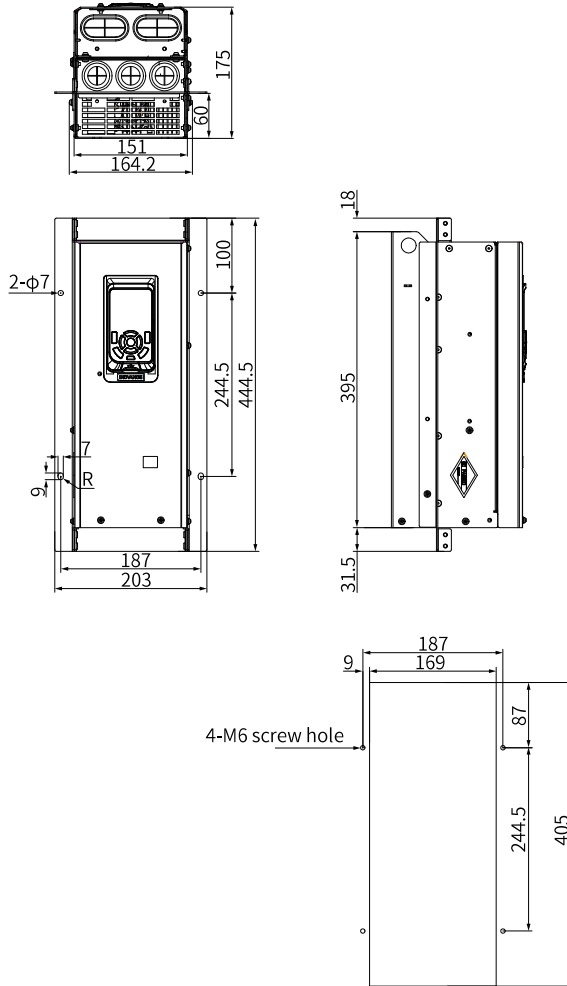

Figure 4-4 Mounting-hole dimensions (mm) of MD580-AZJ-A2T1

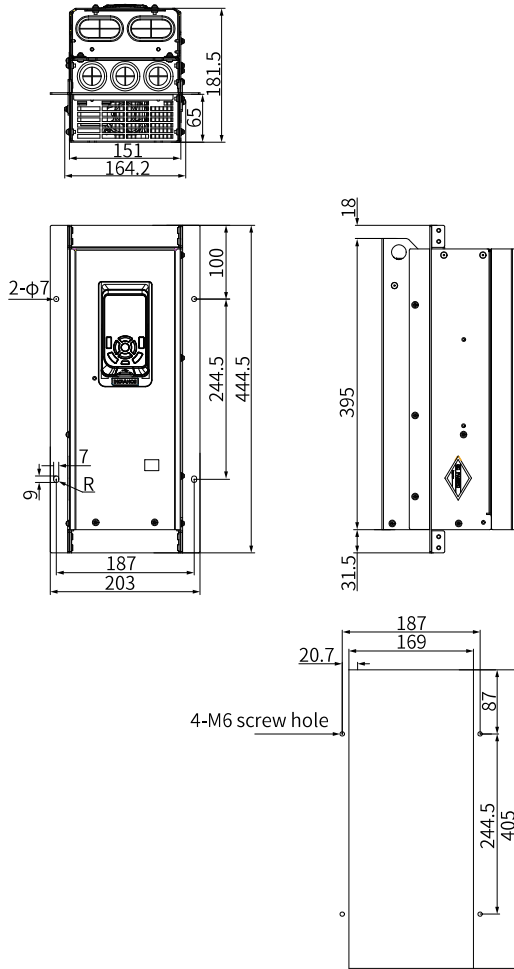

Figure 4-5 Mounting-hole dimensions (mm) of MD580-AZJ-A2T2

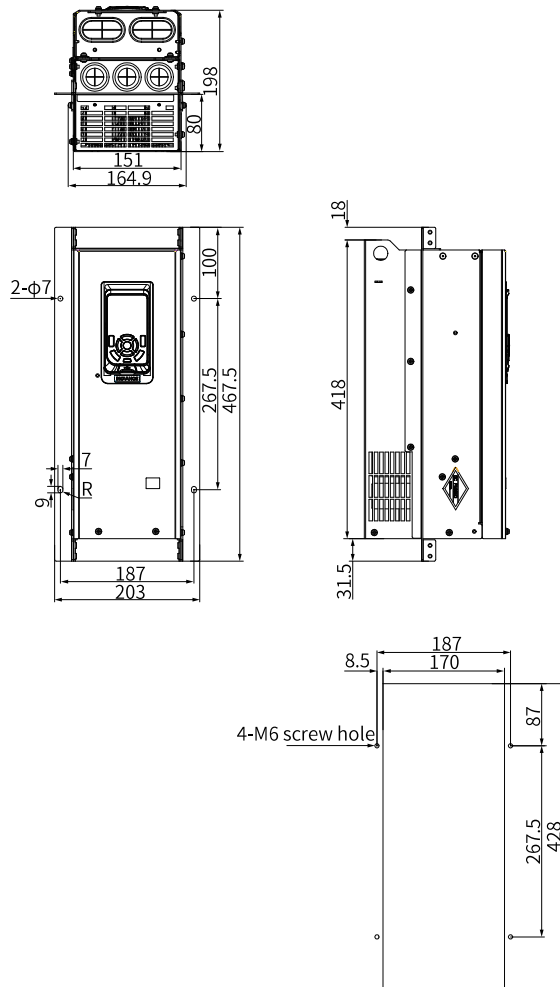

Figure 4-6 Mounting-hole dimensions (mm) of MD580-AZJ-A2T3

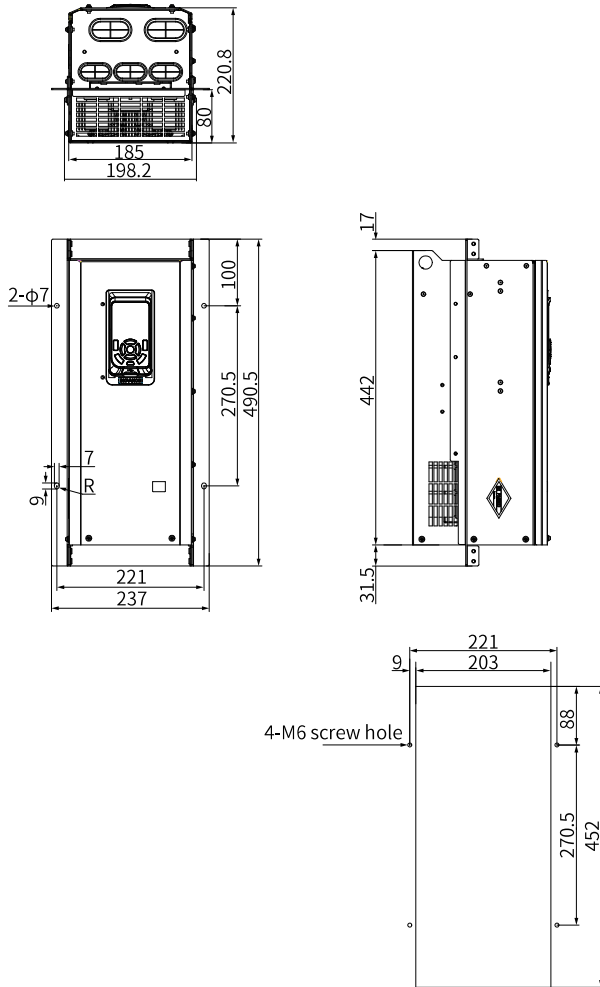

Figure 4-7 Mounting-hole dimensions (mm) of MD580-AZJ-A2T4

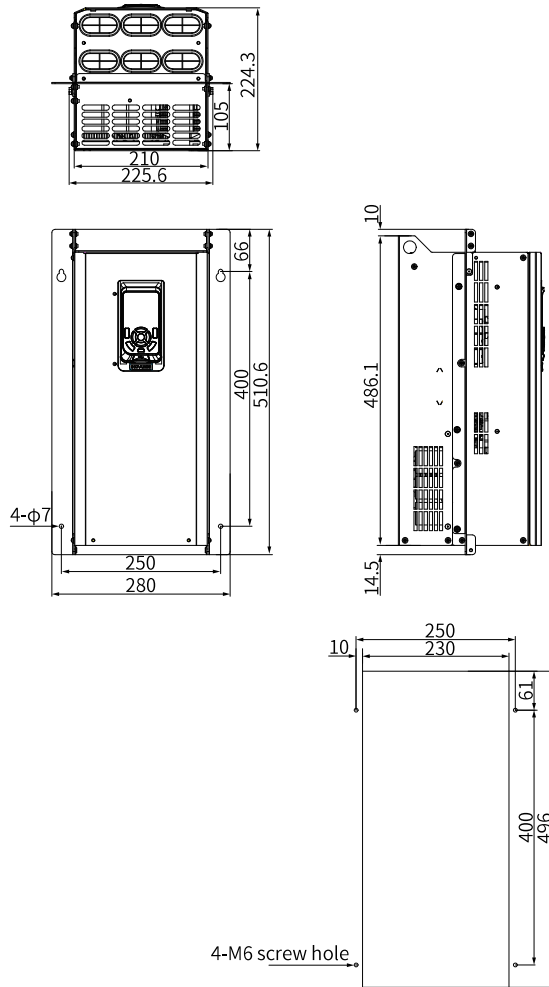

Figure 4-8 Mounting-hole dimensions (mm) of MD580-AZJ-A2T5

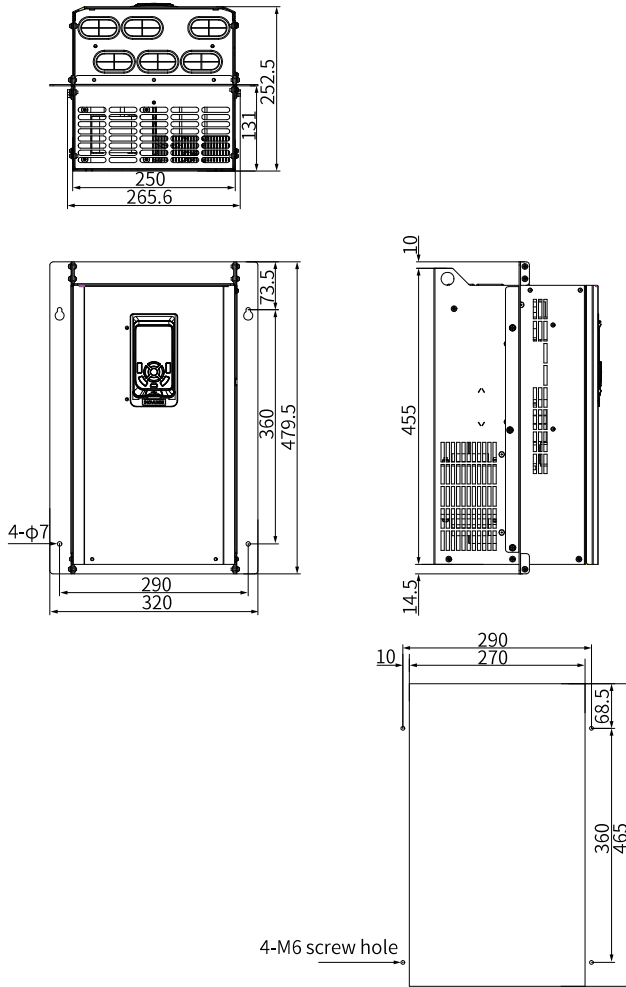

Figure 4-9 Mounting-hole dimensions (mm) of MD580-AZJ-A2T6

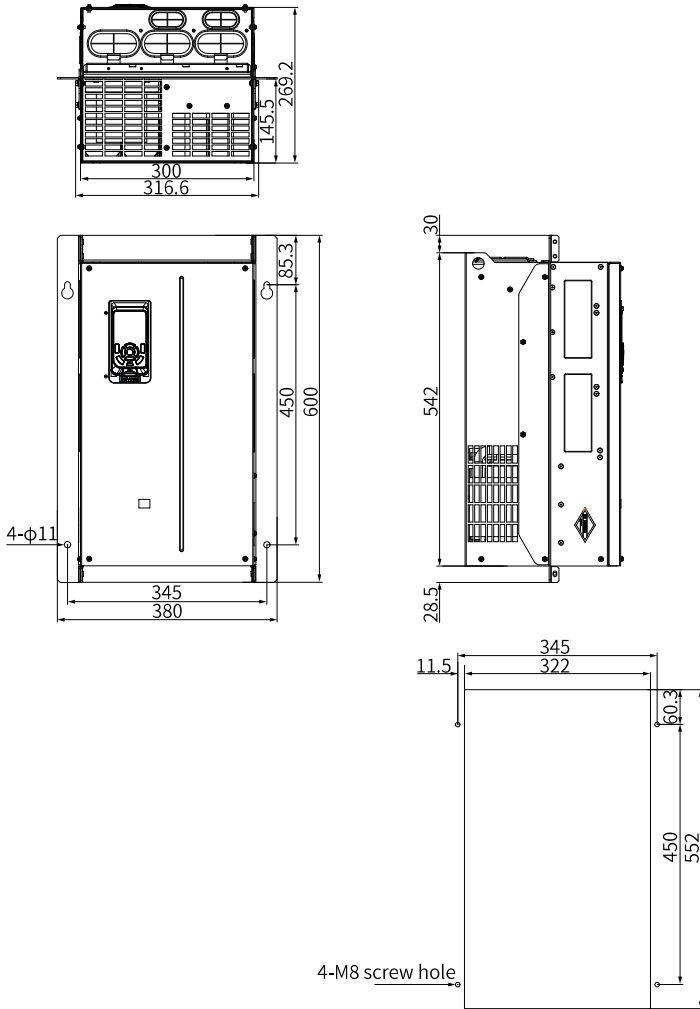

Figure 4-10 Mounting-hole dimensions (mm) of MD580-AZJ-A2T7

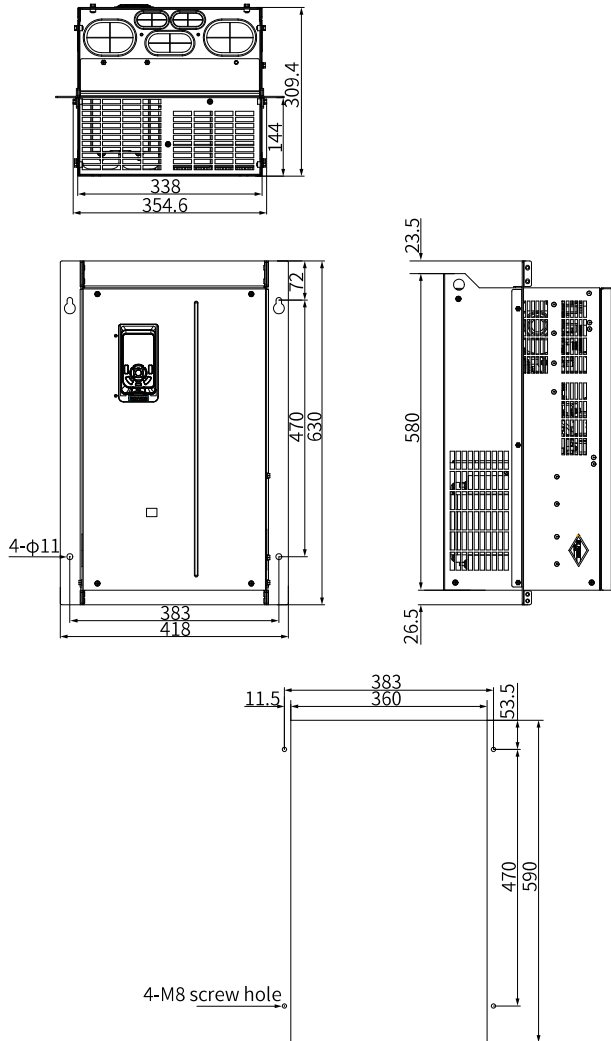

Figure 4-11 Mounting-hole dimensions (mm) of MD580-AZJ-A2T8

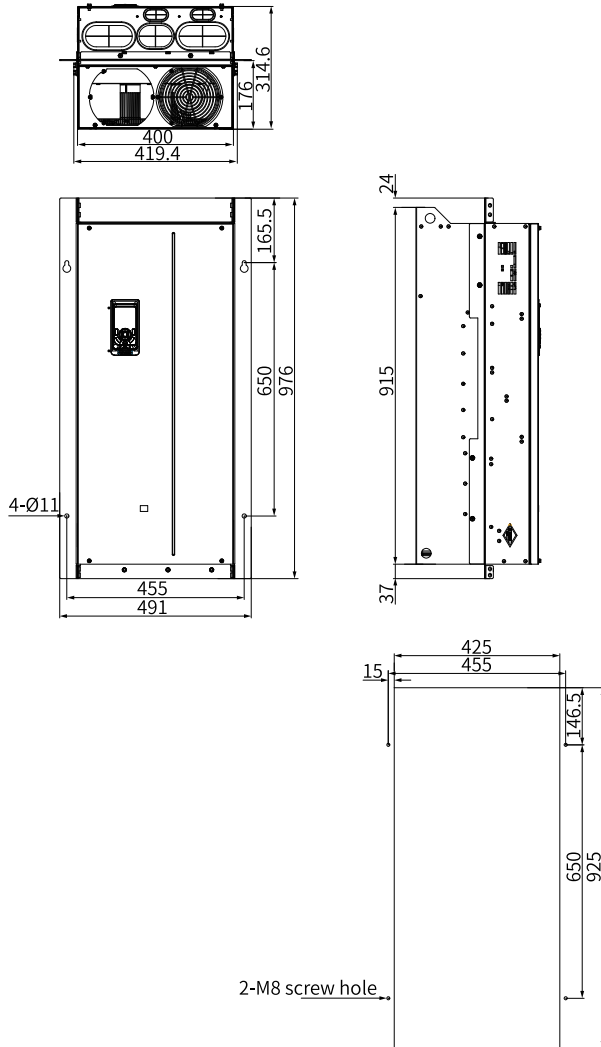

Figure 4-12 Mounting-hole dimensions (mm) of MD580-AZJ-A2T9

## 4.3 Peripheral Electrical Devices

### 4.3.1 Fuse, Contactor, and Circuit Breaker

Table 4-3 Selection of peripheral electrical components for the AC drive

AC Drive Model	Heavy Load/ Light Load	RST/UVW		Grounding Cable		Terminal Width of the drive (mm)	Screw	Bussmann Fuse (UL-compliant)		Contactor Specification	Circuit Breaker Specification
		Cable (m m <sup>2</sup> ) <sup>&lt;1&gt;</sup>	Cable Lug Model	Cable (m m <sup>2</sup> ) <sup>&lt;1&gt;</sup>	Cable Lug Model			Rated Current (A)	Model		
Three-phase 380 V to 480 V, 50/60 Hz											
MD580-4T2R1B	0.4G/ 0.7PB	3 x 0.75	TN R1.25-4	0.75	TN R1.25-4	10.2	M4	5	FWP-5B	9	4
MD580-4T3R1B	0.7G/ 1.1PB	3 x 0.75	TN R1.25-4	0.75	TN R1.25-4	10.2	M4	10	FWP-10B	9	6
MD580-4T3R8B	1.1G/ 1.5PB	3 x 0.75	TN R1.25-4	0.75	TN R1.25-4	10.2	M4	10	FWP-10B	9	6
MD580-4T5R1B	1.5G/ 2.2PB	3 x 0.75	TN R1.25-4	0.75	TN R1.25-4	10.2	M4	15	FWP-15B	9	10
MD580-4T7R2B	2.2G/ 3.0PB	3 x 1	TN R1.25-4	1	TN R1.25-4	10.2	M4	20	FWP-20B	12	13
MD580-4T9B	3.0G/ 3.7PB	3 x 1.5	TNR2-4	1.5	TNR2-4	10.2	M4	20	FWP-20B	16	16
MD580-4T13B	3.7G/ 5.5PB	3 x 2.5	TNR3.5-4	2.5	TNR3.5-4	10.2	M4	30	FWP-30B	26	25
MD580-4T17B	5.5G/ 7.5PB	3 x 4	TNR5.5-4	4	TNR5.5-4	10.2	M4	40	FWP-40B	26	32
MD580-4T25B	7.5G/ 11PB	3 x 6	GTNR6-5	6	GTNR6-5	13	M5	60	FWP-60B	38	50
MD580-4T32B	11G/ 15PB	3 x 10	GTN R10-5	10	GTN R10-5	13	M5	70	FWP-70B	50	50
MD580-4T37B	15G/ 18.5PB	3 x 10	GTN R10-5	10	GTN R10-5	14.3	M5	90	FWP-90B	65	63
MD580-4T45(B)	18.5G/ 22P(B)	3 x 16	GTN R16-6	16	GTN R16-6	15	M6	100	FWH-100C	65	80
MD580-4T60(B)	22G/ 30P(B)	3 x 16	GTN R16-6	16	GTN R16-6	15	M6	125	FWH-125C	80	80
MD580-4T75(B)	30G/ 37P(B)	3 x 25	GTN R25-6	16	GTN R16-6	18	M6	125	FWH-125C	95	100
MD580-4T91(B)	37G/ 45P(B)	3 x 35	GTN R35-6	25	GTN R25-6	18	M6	150	FWH-150C	115	160
MD580-4T112(B)	45G/ 55P(B)	3 x 50	GTN R50-8	35	GTN R35-8	26.8	M8	200	FWH-200C	150	160

AC Drive Model	Heavy Load/Light Load	RST/UWV		Grounding Cable		Terminal Width of the drive (mm)	Screw	Bussmann Fuse (UL-compliant)		Contactor Specification	Circuit Breaker Specification
		Cable (m m <sup>2</sup> ) <sup>&lt;1&gt;</sup>	Cable Lug Model	Cable (m m <sup>2</sup> ) <sup>&lt;1&gt;</sup>	Cable Lug Model			Rated Current (A)	Model		
MD580-4T150(B)	55G/75P(B)	3 x 70	GTN R70-8	50	GTN R50-8	26.8	M8	250	FWH-250C	205	250
MD580-4T176(B)	75G/90P(B)	3 x 95	GTN R95-12	70	GTN R70-12	30.6	M12	275	FWH-275C	245	250
MD580-4T210	90G/110P	3 x 120	GTN R120-12	95	GTN R95-12	30.6	M12	350	FWH-350C	300	250
MD580-4T253	110G/132P	3 x 150	BC150-12	95	GTN R95-12	30.6	M12	400	FWH-400C	410	400
MD580-4T304	132G/160P	3 x 185	BC185-12	120	GTN R120-12	40	M12	500	FWH-500C	410	400
MD580-4T377	160G/200P	2 x (3 x 95)	GTN R95-12	120	GTN R120-12	40	M12	600	FWH-600C	475	500
MD580-4T426(-L)	200G/220P	2 x (3 x 120)	GTN R120-12	150	BC150-12	*	M12	700	FWH-700C	620	630
MD580-4T465(-L)	220G/250P	2 x (3 x 120)	GTN R120-12	150	BC150-12	*	M12	800	FWH-800C	620	630
MD580-4T520(-L)	250G/280P	2 x (3 x 150)	BC150-12	185	BC185-12	*	M12	900	170M5015	800	630
MD580-4T585(-L)	280G/315P	2 x (3 x 185)	BC185-12	240	BC240-12	*	M12	1000	170M5016	800	800
MD580-4T650(-L)	315G/355P	2 x (3 x 185)	BC185-16	240	BC240-16	*	M16	1100	170M5017	800	800
MD580-4T725(-L)	355G/400P	2 x (3 x 240)	BC240-16	300	BC300-16	*	M16	1400	170M6017	1000	1000
MD580-4T820(-L)	400G/450P	2 x (3 x 300)	BC300-16	300	BC300-16	*	M16	1400	170M6017	1000	1000

## Note

- <1>: GB standards apply. For example, 3 x 10 indicates one 3-conductor 10 mm<sup>2</sup> cable; 2 x (3 x 10) indicates two 3-conductor 10 mm<sup>2</sup> cables.
- The preceding recommended lugs are the TNR, GTNR, and BC series of Suzhou Yuanli.
- The recommended temperature resistance of the cable is 70°C (PVC), and the current carrying capacity varies with the temperature resistance level.
- The recommended specifications of fuses, contactors, and circuit breakers are obtained at room temperature below 40°C. They are for reference only. Select specifications based on the actual operating environment.



To avoid electric shocks, do not resume power supply to the product or operate peripherals immediately after a fuse burns or a circuit breaker trips. Instead, wait at least a period of time specified on the product warning label before further operations. Failure to comply may result in product damage, several injuries, or even death.

To comply with EN 6180051 and UL61800-5-1 standards, install a fuse/circuit breaker on the input side of the drive to prevent accidents caused by short circuit in the internal circuit.

The following tables list recommended fuses and circuit breakers manufactured by Bussmann.

Table 4–4 Selection of fuses, contactors, and circuit breakers (three phase 380–480 V)

Structure	AC Drive Model	Bussmann Fuse (UL-compliant)		Contactor Specification	Circuit Breaker Specification
		Rated Current (A)	Model	Rated Current (A)	Rated Current (A)
T1	MD580-4T2R1B	5	FWP-5B	9	4
	MD580-4T3R1B	10	FWP-10B	9	6
	MD580-4T3R8B	10	FWP-10B	9	6
	MD580-4T5R1B	15	FWP-15B	9	10
	MD580-4T7R2B	20	FWP-20B	12	13
	MD580-4T9B	20	FWP-20B	16	16
T2	MD580-4T13B	30	FWP-30B	26	25
	MD580-4T17B	40	FWP-40B	26	32
T3	MD580-4T25B	60	FWP-60B	38	50
	MD580-4T32B	70	FWP-70B	50	50
T4	MD580-4T37B	90	FWP-90B	65	63

Structure	AC Drive Model	Bussmann Fuse (UL-compliant)		Contactor Specification	Circuit Breaker Specification
		Rated Current (A)	Model	Rated Current (A)	Rated Current (A)
T5	MD580-4T45(B)	100	FWH-100C	65	80
	MD580-4T60(B)	125	FWH-125C	80	80
T6	MD580-4T75(B)	125	FWH-125C	95	100
	MD580-4T91(B)	150	FWH-150C	115	160
T7	MD580-4T112(B)	200	FWH-200C	150	160
	MD580-4T150(B)	250	FWH-250C	205	250
T8	MD580-4T176(B)	275	FWH-275C	245	250
	MD580-4T210	350	FWH-350C	300	250
	MD580-4T253	400	FWH-400C	410	400
T9	MD580-4T304	500	FWH-500C	410	400
	MD580-4T377	600	FWH-600C	475	500
T10	MD580-4T426(-L)	700	FWH-700C	620	630
	MD580-4T426(-L)	800	FWH-800C	620	630
T11	MD580-4T426(-L)	900	170M5015	800	630
	MD580-4T426(-L)	1000	170M5016	800	800
T12	MD580-4T650(-L)	1100	170M5017	800	800
	MD580-4T725(-L)	1400	170M6017	1000	1000
	MD580-4T820(-L)	1400	170M6017	1000	1000

### 4.3.2 AC Input Reactor

An AC input reactor is optional and mainly used to reduce harmonics in the input current. Install an external reactor as needed in actual applications.

If an AC input reactor is required for models with the power over 200 kW, reserve sufficient installation space in the cabinet for the reactor.

#### Models and dimensions (Inovance)

Recommended AC input reactor manufacturers and models are listed in the following tables.

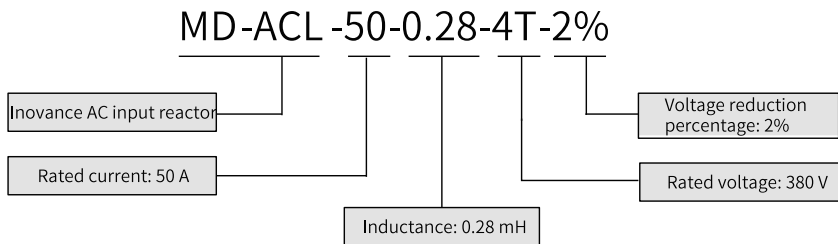

Figure 4-13 AC input reactor model

Table 4-5 Selection of AC input reactors (three-phase 380 V to 480 V)

Structure	AC Drive Model	Applicable Reactor	Inductance (mH)	Loss (W)
T1	MD580-4T2R1B	MD-ACL-10-5-4T	5	50
	MD580-4T3R1B	MD-ACL-10-5-4T	5	50
	MD580-4T3R8B	MD-ACL-10-5-4T	5	50
	MD580-4T5R1B	MD-ACL-10-5-4T	5	50
	MD580-4T7R2B	MD-ACL-10-5-4T	5	50
	MD580-4T9B	MD-ACL-15-3-4T	3	50
T2	MD580-4T13B	MD-ACL-40-1.45-4T	1.45	100
	MD580-4T17B	MD-ACL-40-1.45-4T	1.45	100
T3	MD580-4T25B	MD-ACL-40-1.45-4T	1.45	100
	MD580-4T32B	MD-ACL-40-1.45-4T	1.45	100
T4	MD580-4T37B	MD-ACL-50-0.28-4T-2%	0.28	-
T5	MD580-4T45(B)	MD-ACL-60-0.24-4T-2%	0.24	-
	MD580-4T60(B)	MD-ACL-90-0.16-4T-2%	0.17	-
T6	MD580-4T75(B)	MD-ACL-90-0.16-4T-2%	0.17	-
	MD580-4T91(B)	MD-ACL-90-0.16-4T-2%	0.16	-
T7	MD580-4T112(B)	MD-ACL-120-0.12-4T-2%	0.12	-
	MD580-4T150(B)	MD-ACL-150-0.095-4T-2%	0.095	-
T8	MD580-4T176(B)	MD-ACL-200-0.07-4T-2%	0.07	-
	MD580-4T210	MD-ACL-200-0.07-4T-2%	0.07	-
	MD580-4T253	MD-ACL-200-0.07-4T-2%	0.056	-
T9	MD580-4T304	MD-ACL-330-0.042-4T-2%	0.042	-
	MD580-4T377	MD-ACL-490-0.028-4T-2%	0.028	-
T10	MD580-4T426(-L)	MD-ACL-490-0.028-4T-2%	0.028	-
	MD580-4T465(-L)	MD-ACL-490-0.028-4T-2%	0.028	-
T11	MD580-4T520(-L)	MD-ACL-660-0.021-4T-2%	0.021	-
	MD580-4T585(-L)	MD-ACL-660-0.021-4T-2%	0.021	-
T12	MD580-4T650(-L)	MD-ACL-660-0.021-4T-2%	0.017	-
	MD580-4T725(-L)	MD-ACL-800-0.017-4T-2%	0.017	-
	MD580-4T820(-L)	MD-ACL-800-0.017-4T-2%	0.014	-

## Dimensions

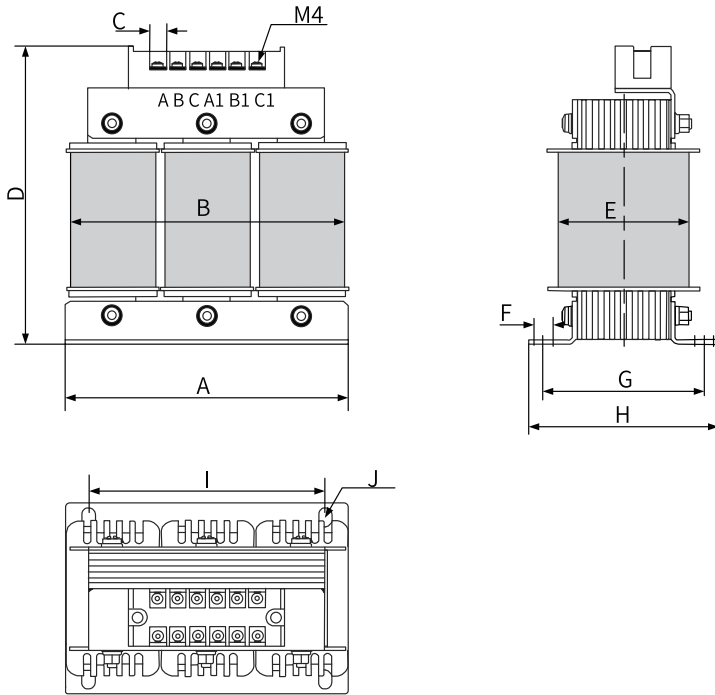

Figure 4-14 Dimensions of AC input reactors (10 A/15 A)

Table 4-6 Dimensions of AC input reactors (10 A/15 A) (unit: mm)

Rated Current (A)	A	B	C	D	E	F	G	H	I	J
10	150±2	155	8	160	80	10	85±2	100±2	125±1	Φ7*10
15	150±2	155	8	160	80	10	85±2	100±2	125±1	Φ7*10

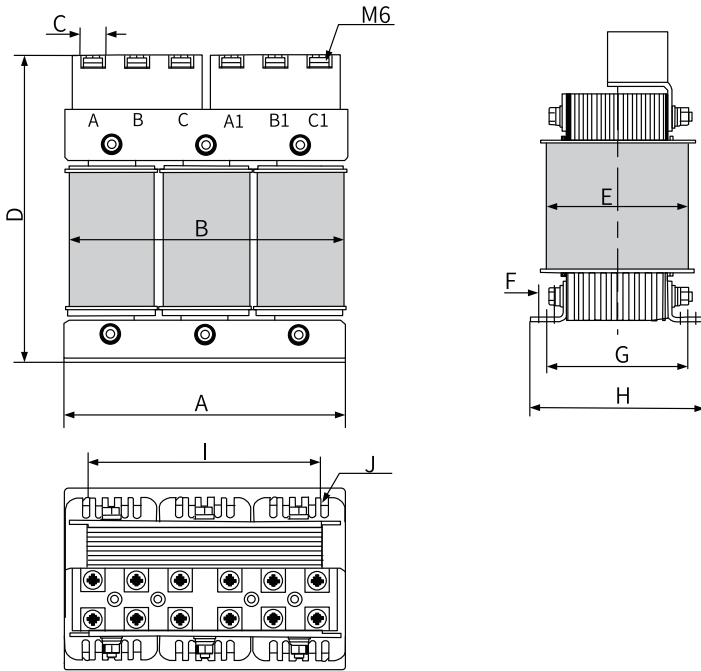

Figure 4-15 Dimensions of AC input reactors (40 A, 50 A/1.2 mH)

Table 4-7 Dimensions of AC input reactors (40 A, 50 A/1.2 mH) (unit: mm)

Rated Current (A)	A	B	C	D	E	F	G	H	I	J
40	180±2	185	16	200	105	10	95±2	117±2	150±1	Φ7*10
50	200±2	210	16	230	110	10	115±2	130±2	170±1	Φ7*10

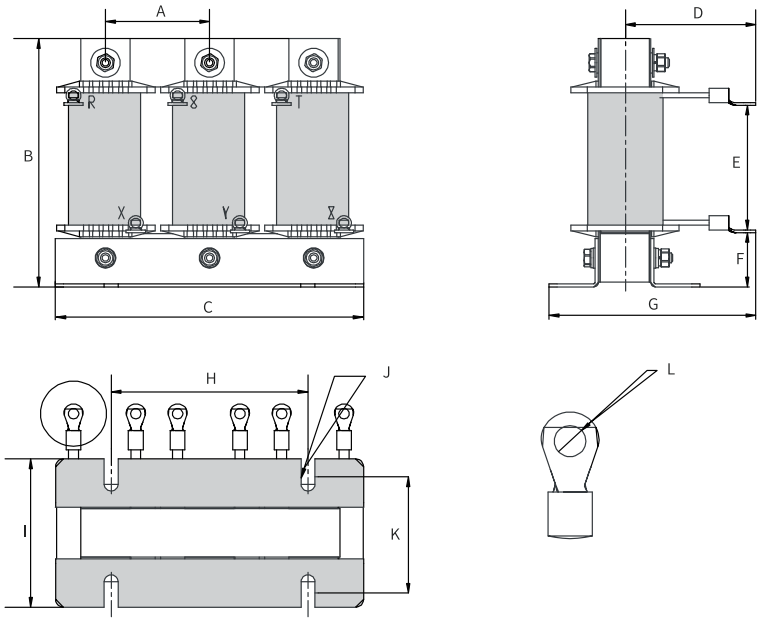

Figure 4-16 Dimensions of AC input reactors (50 A/0.28 mH, 60 A)

Table 4-8 Dimensions of AC input reactors (50 A/0.28 mH, 60 A) (unit: mm)

Rated Current (A)	A	B	C	D	E	F	G	H	I	J	K	L
50	64	160	195	80±10	75±5	35±5	135	120±1	92±2	Φ8.5*20	72±2	Φ6.4
60	64	160	195	80±10	75±5	35±5	135	120±1	92±2	Φ8.5*20	72±2	Φ6.4

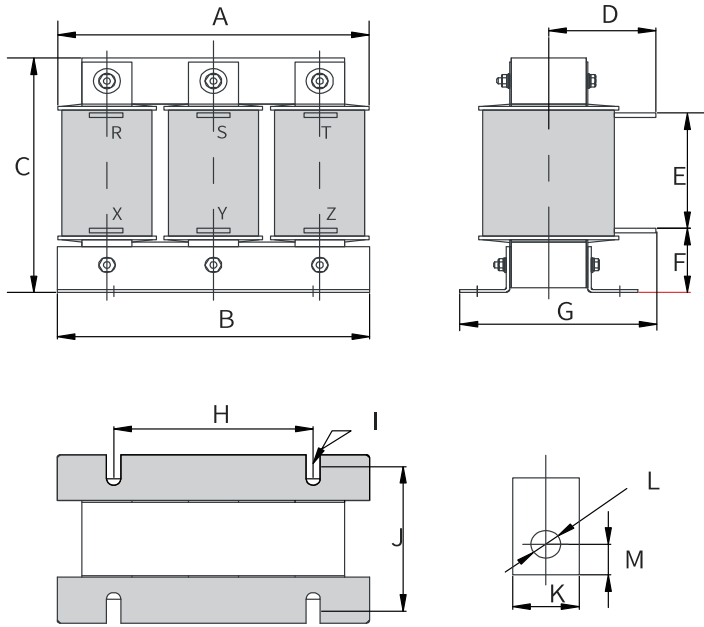

Figure 4-17 Dimensions of AC input reactors (80-120 A)

Table 4-9 Dimensions of AC input reactor (80-120 A) (unit: mm)

Rated Current (A)	A	B	C	D	E	F	G	H	I	J	K	L	M
80	195	188±1	160	-	-	-	150	120±1	Φ8.5*20	72±2	-	-	-
90	195	188±1	160	-	-	-	150	120±1	Φ8.5*20	72±2	-	-	-
120	195	188±1	160	78±10	79±5	40±5	135	120±1	Φ8.5*20	92±2	20	Φ9	10

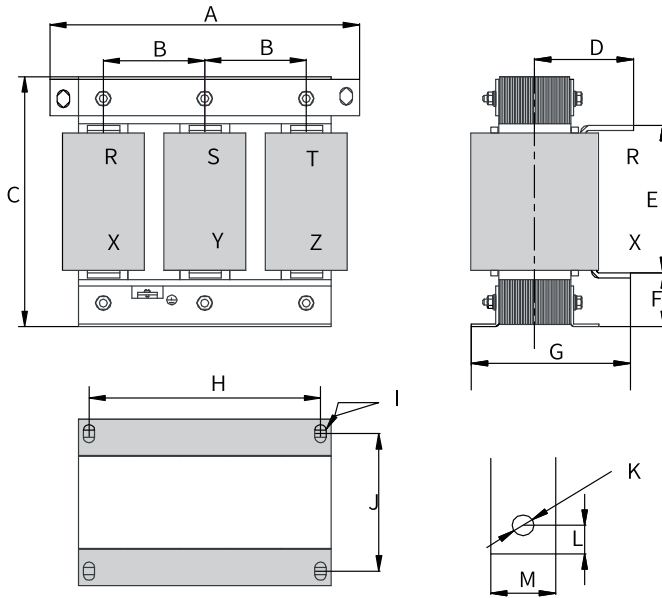

Figure 4-18 Dimensions of AC input reactors (150-330 A)

Table 4-10 Dimensions of AC input reactor (150-330 A) (unit: mm)

Rated Current (A)	A	B	C	D	E	F	G	H	I	J	K	L	M
150	250	81±5	230	92±10	145±5	38±5	155	182±1	Φ11*18	76±2	Φ11	13	25
200	250	81±5	230	102±10	145±5	40±5	175	182±1	Φ11*18	96±2	Φ11	13	25
250	250	81±5	260	102±10	160±5	50±5	175	182±1	Φ11*18	96±2	Φ11	13	25
330	290	95±5	275	107±10	160±5	60±5	180	214±1	Φ11*18	100±2	Φ12	15	30

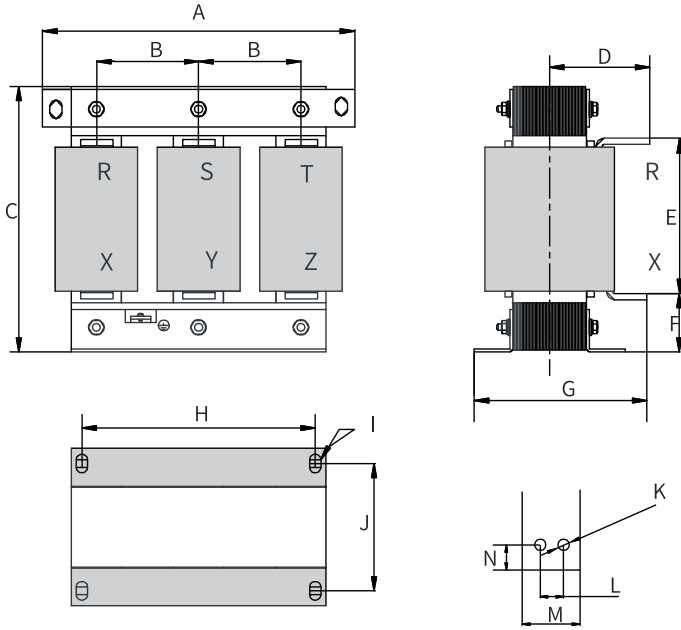

Figure 4-19 Dimensions of AC input reactors (490 A/660 A)

Table 4-11 Dimensions of AC input reactors (490 A/660 A) (unit: mm)

Rated Current (A)	A	B	C	D	E	F	G	H	I	J	K	L	M	N
490	320	106±5	305	137±10	198±5	60±5	220	243±1	Φ12*20	122±2	Φ12	22	50	23
660	320	106±5	305	145±10	203±5	50±5	240	243±1	Φ12*20	137±2	Φ12	22	50	23

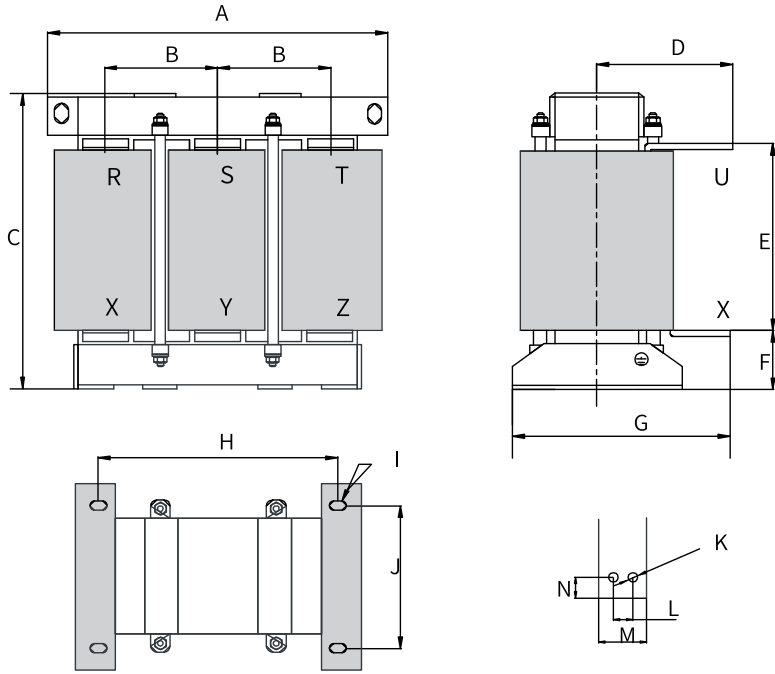

Figure 4-20 Dimensions of AC input reactors (800-1000 A)

Table 4-12 Dimensions of AC input reactors (800 A/1000 A) (unit: mm)

Rated Current (A)	A	B	C	D	E	F	G	H	I	J	K	L	M	N
800	385	123±5	390	142±10	238±5	70±5	250	260±2	Φ12*20	175±1	Φ12	22	50	23
1000	385	123±5	390	142±10	238±5	70±5	250	260±2	Φ12*20	175±1	Φ12	22	50	23

The dimensions provided here are for reference only. Actual product may vary.

## Models and dimensions (Schaffner)

Table 4-13 Selection of Schaffner AC input reactors (three-phase 380 V to 480 V)

Structure	AC Drive Model	Applicable Reactor	Inductance (mH)	Loss (W)
T1	MD580-4T2R1B	RWK 3044-3.5-88-E0XXX	8.3	32
	MD580-4T3R1B	RWK 3044-6.5-88-E0XXX	4.6	47
	MD580-4T3R8B	RWK 3044-6.5-88-E0XXX	4.6	47
	MD580-4T5R1B	RWK 3044-6.5-88-E0XXX	4.6	47
	MD580-4T7R2B	RWK 3044-12-88-E0XXX	2.44	69
	MD580-4T9B	RWK 3044-12-88-E0XXX	2.44	69
T2	MD580-4T13B	RWK 3044-18-89-E0XXX	1.67	103
	MD580-4T17B	RWK 3044-24-89-E0XXX	1.22	106
T3	MD580-4T25B	RWK 3044-35-92-E0XXX	0.83	151
	MD580-4T32B	RWK 3044-48-92-E0XXX	0.61	172
T4	MD580-4T37B	RWK 3044-59-92-E0XXX	0.5	206
T5	MD580-4T45(B)	RWK 3044-59-92-E0XXX	0.5	206
	MD580-4T60(B)	RWK 3044-72-99-E0XXX	0.41	294
T6	MD580-4T75(B)	RWK 3044-72-99-E0XXX	0.41	294
	MD580-4T91(B)	RWK 3044-120-99-E0XXX	0.24	324
T7	MD580-4T112(B)	RWK 3044-120-99-E0XXX	0.24	324
	MD580-4T150(B)	RWK 3044-180-99-E0XXX	0.17	456
T8	MD580-4T176(B)	RWK 3044-180-99-E0XXX	0.17	456
	MD580-4T210	RWK 3044-210-99-E0XXX	0.14	553
	MD580-4T253	RWK 3044-260-99-E0XXX	0.11	593
T9	MD580-4T304	RWK 3044-320-99-E0XXX	0.092	747
	MD580-4T377	RWK 3044-400-99-E0XXX	0.073	1055
T10	MD580-4T426-L	RWK 3044-510-99-E0XXX	0.058	1069
	MD580-4T465-L	RWK 3044-510-99-E0XXX	0.058	1069
T11	MD580-4T520-L	RWK 3044-510-99-E0XXX	0.058	1069
	MD580-4T585-L	RWK 3044-570-99-E0XXX	0.052	1181
T12	MD580-4T650-L	RWK 3044-640-99-E0XXX	0.046	1116
	MD580-4T725-L	RWK 3044-800-99-E0XXX	0.037	1280
	MD580-4T820-L	RWK 3044-800-99-E0XXX	0.037	1280





### 4.3.3 EMC Filter

#### Overview

To comply with the radiated and conducted emission requirements of EN IEC 618003, install the EMC filter listed in the following table. The following EMC filters can be used.

The AC drives with all power ratings can meet requirements of EN 61800-3 C3.

Table 4-14 Standard EMC filter model and appearance

Filter Model	Appearance
Schaffner series	FN2090 Series 
	FN 3258 series 
	FN 3359 series 
Jianli series	TH series 
	EBK5 Series 

## Models and dimensions (Schaffner filters)

Table 4–15 Selection of Schaffner filters (three-phase 380 V to 480 V)

Structure	AC Drive Model	Filter Model	Loss (W)
T1	MD580-4T2R1B	FN3258-7-44	3.8
	MD580-4T3R1B	FN3258-7-44	3.8
	MD580-4T3R8B	FN3258-7-44	3.8
	MD580-4T5R1B	FN3258-7-44	3.8
	MD580-4T7R2B	FN3258-16-45	6.1
	MD580-4T9B	FN3258-16-45	6.1
T2	MD580-4T13B	FN3258-16-45	6.1
	MD580-4T17B	FN3258-30-47	11.8
T3	MD580-4T25B	FN3258-42-33	15.7
	MD580-4T32B	FN3258-42-33	15.7
T4	MD580-4T37B	FN3258-55-34	25.9
T5	MD580-4T45(B)	FN3258-75-34	31.2
	MD580-4T60(B)	FN3258-75-34	31.2
T6	MD580-4T75(B)	FN3258-75-34	31.2
	MD580-4T91(B)	FN3258-100-35	34.5
T7	MD580-4T112(B)	FN3258-130-35	43.1
	MD580-4T150(B)	FN3258-180-40	58.3
T8	MD580-4T176(B)	FN3258-180-40	58.3
	MD580-4T210	FN3359-250-28	49
	MD580-4T253	FN3359-250-28	49
T9	MD580-4T304	FN3359-320-99	19
	MD580-4T377	FN3359-400-99	29
T10	MD580-4T426(-L)	FN3359-600-99	44
	MD580-4T465(-L)	FN3359-600-99	44
T11	MD580-4T520(-L)	FN3359-600-99	44
	MD580-4T585(-L)	FN3359-600-99	44
T12	MD580-4T650(-L)	FN3359-800-99	39
	MD580-4T725(-L)	FN3359-800-99	39
	MD580-4T820(-L)	FN3359-800-99	39

The following figure shows the dimensions of FN 3258 series filters (50-180 A).

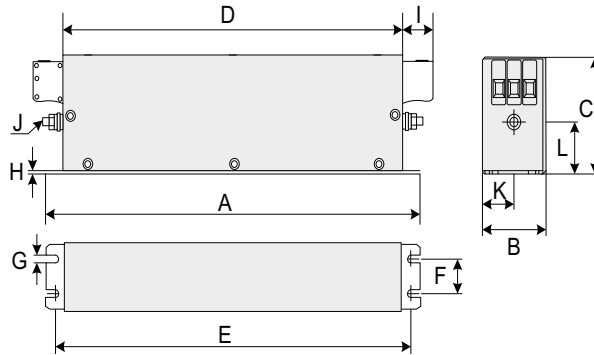

Figure 4-21 Dimensions of FN 3258 series filters (50 A to 180 A)

Table 4-16 Dimensions of FN 3258 series filters (50-180 A, unit: mm)

Rated Current (A)	A	B	C	D	E	F	G	H	I	J	K	L
7	190	40	70	160	180	20	4.5	1	22	M5	20	29.5
16	250	45	70	220	235	25	5.4	1	22	M5	22.5	29.5
30	270	50	85	240	255	30	5.4	1	25	M5	25	39.5
42	310	50	85	280	295	30	5.4	1	25	M6	25	37.5
55	250	85	90	220	235	60	5.4	1	39	M6	42.5	26.5
75	270	80	135	240	255	60	6.5	1.5	39	M6	40	70.5
100	270	90	150	240	255	65	6.5	1.5	45	M10	45	64
130	270	90	150	240	255	65	6.5	1.5	45	M10	45	64
180	380	120	170	350	365	102	6.5	1.5	51	M10	60	47

The following figure shows the dimensions of FN 3359 series filters (150-250 A).

150 A to 250 A

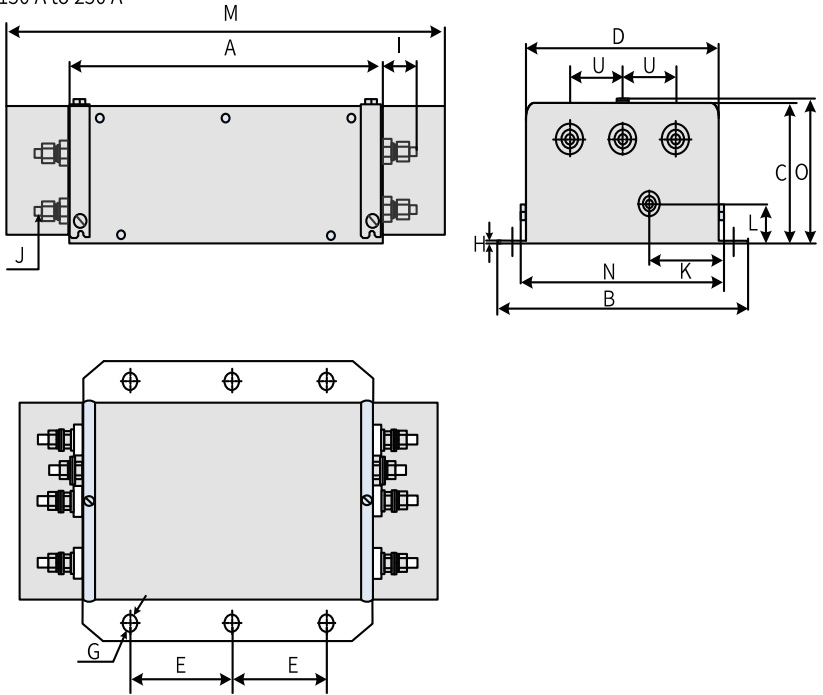

Figure 4-22 Dimensions of FN 3359 series filters (150-250 A)

Table 4-17 Dimensions of FN 3359 series filters (150-250 A, unit: mm)

Mark	Rated Current		
	150 A	180 A	250 A
A	300	300	300
B	210	210	230
C	120	120	125
D	160	160	180
E	120	120	120
F	185	185	205
G	φ12	φ12	φ12
H	2	2	2
I	33	33	33
J	M10	M10	M10
K	55	55	62.5
L	30	30	35
M	420	420	420
N	171	171	191
O	127	127	132

Mark	Rated Current		
	150 A	180 A	250 A
S	-	-	-
T	-	-	-
U	50	50	55
V	-	-	-
W	-	-	-
X	-	-	-
Y	-	-	-
Z	-	-	-

The following figure shows the dimensions of FN 3359 series filters (320-2500 A).

320 A to 2500 A

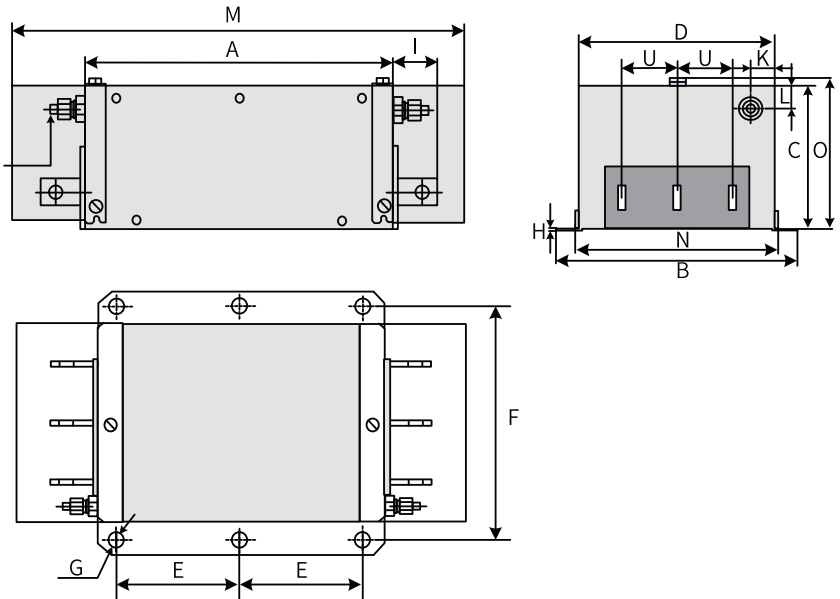

Figure 4-23 Dimensions of FN 3359 series filters (320-2500 A)

The following figure shows the dimensions of the copper busbar.

320 A to 1000 A

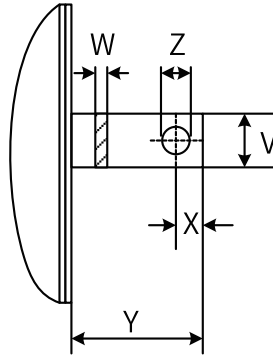

Figure 4-24 Dimensions of copper busbars

Table 4-18 Dimensions of FN 3359 series filters (320-2500 A unit: mm)

Mark	Rated Current						
	320 A	400 A	600 A	800 A	1000 A	1600 A	2500 A
A	300	300	300	350	350	400	600
B	260	260	260	280	280	300	370
C	115	115	135	170	170	160	200
D	210	210	210	230	230	250	300
E	120	120	120	145	145	170	250
F	235	235	235	255	255	275	330
G	φ12	φ12	φ12	φ12	φ12	φ12	φ14
H	2	2	2	3	3	3	3
I	43	43	43	53	53	93	98
J	M12	M12	M12	M12	M12	M12	M16
K	20	20	20	25	25	25	25
L	20	20	20	25	25	25	25
M	440	440	440	510	510	-	-
N	221	221	221	241	241	-	-
O	122	122	142	177	177	-	-
S	-	-	-	-	-	26	35
T	-	-	-	-	-	26	35
U	60	60	60	60	60	60	100
V	25	25	25	40	40	60	70
W	6	6	8	8	8	10	15
X	15	15	15	20	20	17	20
Y	40	40	40	50	50	90	95
Z	φ10.5	φ10.5	φ10.5	φ14	φ14	φ14	φ14

## Models and dimensions of Jianli filters

Table 4-19 Selection of Jianli filters (three-phase 380 V to 480 V)

Structure	AC Drive Model	Filter Model	Loss (W)
T1	MD580-4T2R1B	DL-5EBK5	6.9
	MD580-4T3R1B	DL-5EBK5	6.9
	MD580-4T3R8B	DL-5EBK5	6.9
	MD580-4T5R1B	DL-10EBK5	6.9
	MD580-4T7R2B	DL-10EBK5	6.9
	MD580-4T9B	DL-16EBK5	8.5
T2	MD580-4T13B	DL-16EBK5	8.5
	MD580-4T17B	DL-25EBK5	9.4
T3	MD580-4T25B	DL-35EBK5/40	19.2
	MD580-4T32B	DL-50EBK5/40	21.7
T4	MD580-4T37B	DL-50EBK5/40	21.7
T5	MD580-4T45(B)	DL-65EBK5/40	27.4
	MD580-4T60(B)	DL-80EBK5	32.6
T6	MD580-4T75(B)	DL-80EBK5	32.6
	MD580-4T91(B)	DL-100EBK5	33
T7	MD580-4T112(B)	DL-130EBK5-CHV	37.5
	MD580-4T150(B)	DL-160EBK5-CHV	38.4
T8	MD580-4T176(B)	DL-200EBK5	38.4
	MD580-4T210	DL-200EBK5	38.4
	MD580-4T253	DL-250EBK5	49
T9	MD580-4T304	DL-300EBK3	49
	MD580-4T377	DL-400EBK3	29
T10	MD580-4T426-L	DL-450EBK35/60	39
	MD580-4T465-L	DL-600EBK3	44
T11	MD580-4T520-L	DL-600EBK3	44
	MD580-4T585-L	DL-600EBK3	44
T12	MD580-4T650-L	DL-700EBK3	39
	MD580-4T725-L	DL-800EBK3	39
	MD580-4T820-L	DL-800EBK3	39

The following figure shows the dimensions of Jianli filters (50-200 A).

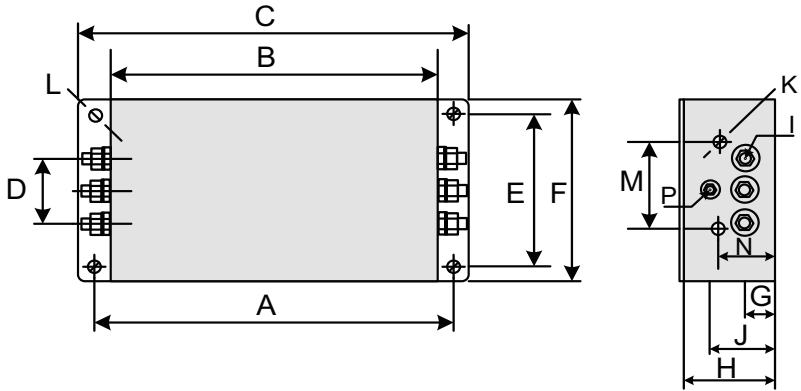
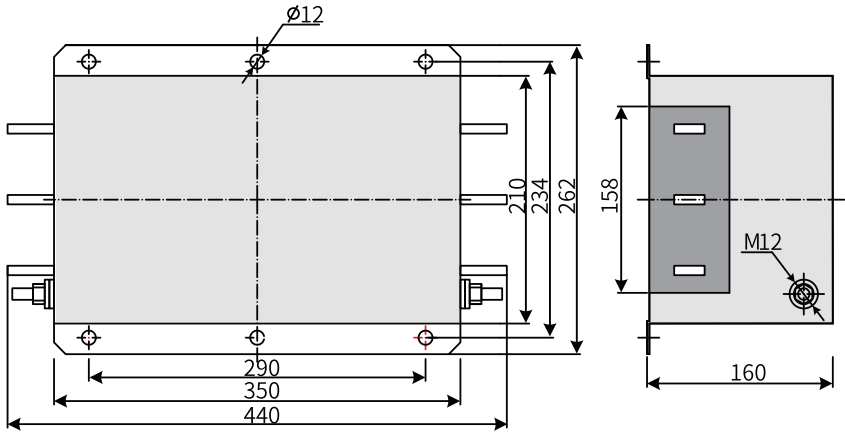

Figure 4-25 Dimensions of Jianli filters (50-200 A)

Table 4-20 Dimensions of Jianli filters (50-200 A, unit: mm)

Model	A	B	C	D	E	F	G	H	I	J	K	M	N	P	L
DL-25EBK5	243	224	265	58	70	102	25	92	M6	58	M4	74	49	M6	6.4 x 9.4
DL-35EBK5															
DL-50EBK5															
DL-65EBK5															
DL-80EBK5	354	323	388	66	155	188	30	92	M8	62	M4	86	56	M8	6.4 x 9.4
DL-100EBK5															
DL-130EBK5															
DL-160EBK5															
DL-200EBK5															

The following figure shows the dimensions of Jianli filters (250-800 A).



250 A to 300 A

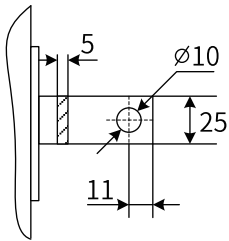

400 A to 600 A

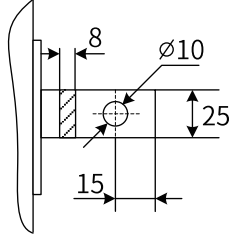

700 A to 800 A

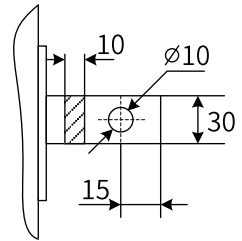

Figure 4-26 Dimensions of Jianli filters (250-800 A, unit: mm)

The following figure shows the dimensions of Jianli filters (1000 A).

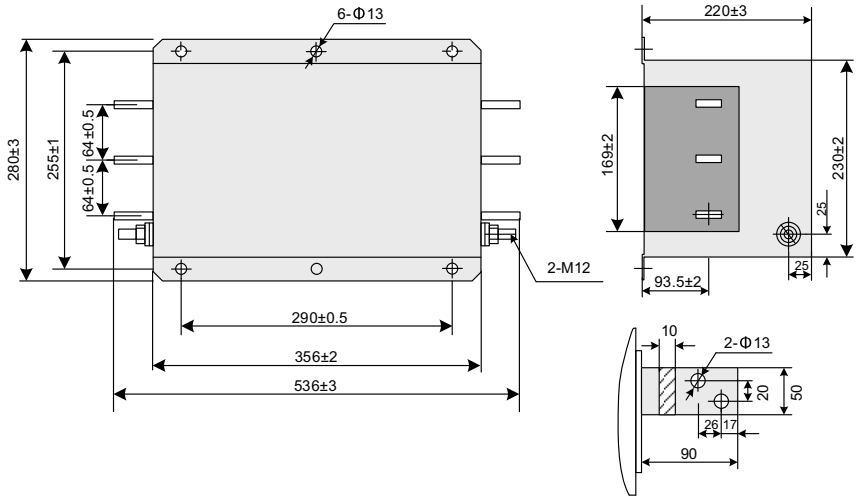

Figure 4-27 Dimensions of Jianli filters (1000 A, unit: mm)

#### 4.3.4 Simple Filter

A simple filter can be used to suppress the RF electromagnetic noise from the power grid and the AC drive during operation. For an AC drive with an earth leakage circuit breaker, a simple filter can be installed on the input side to prevent malfunction of the earth leakage circuit breaker.

The simple filter must be grounded securely and the cable between the filter and AC drive must be shorter than 30 cm. The grounding terminal of the simple filter must be connected to the grounding terminal of the drive, and the grounding cable must be as short as possible and cannot exceed 30 cm.

## Dimensions

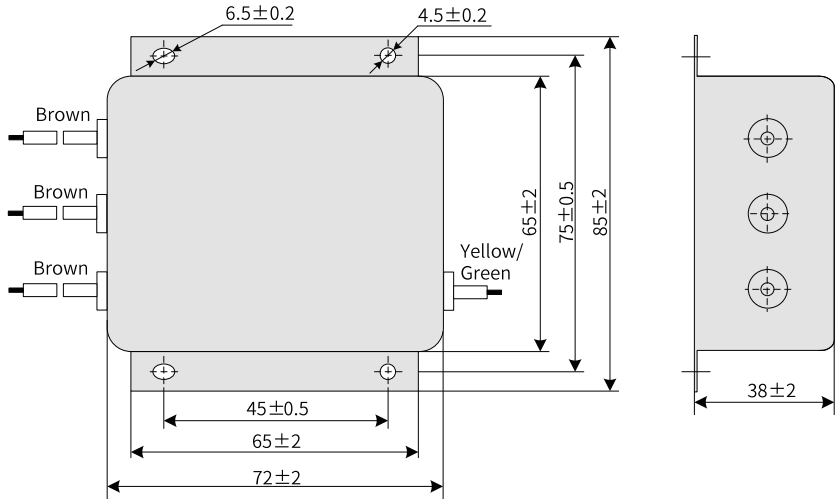

Figure 4-28 Outline dimensions of the simple filter

Table 4-21 Outline dimensions of the simple filter

Model	Code	Dimension (Length x Width x Height) (unit: mm)	Mounting Dimension (Length x Width) (unit: mm)
Cxy-1-1	11025018	85 x 72 x 38	45 x 75

## Installation Method

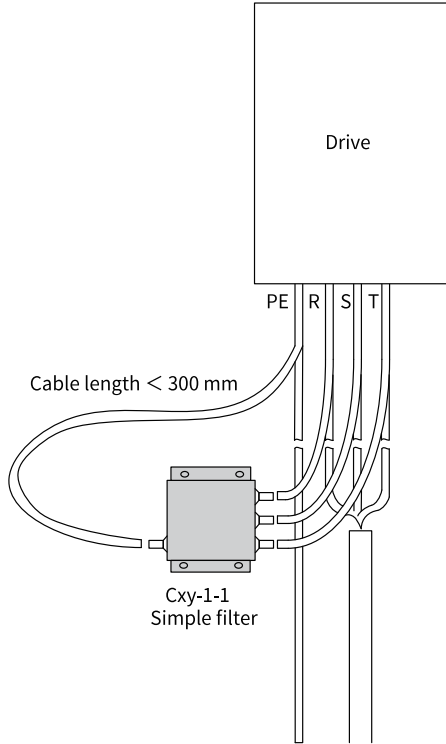

Figure 4-29 Simple filter installation

### 4.3.5 Braking Components

#### Resistance of braking resistors

During braking, almost all the regenerative energy of the motor is consumed by the braking resistor. The resistance of the braking resistor is calculated by the following formula:  $U \times U/R = P_b$ .

U indicates the braking voltage for stable system braking. The value of U varies with systems. The default braking voltage of the AC drive is 760 V, which can be adjusted through F9-08.

$P_b$  indicates the braking power.

#### Power of braking resistors

In theory, the power of the braking resistor is the same as the braking power. However, in consideration of the derating coefficient K, the power of the braking resistor is calculated by the following formula:  $K \times P_r = P_b \times D$ .

K: about 50%

Pr: Power of the braking resistor

D: Braking frequency, which is the proportion of the regenerative process to the whole working process

The following formulas can be generated based on the preceding equations:

$$K \times Pr = Pb \times D = U \times U / R \times D$$

$$Pr = (U \times U \times D) / (R \times K)$$

You can then calculate the power of the braking resistor.

K is the derating factor of the braking resistor. A small K value ensures that the braking resistor does not get overheated. You can increase the value of K properly under favorable heat dissipation conditions of the braking resistor. However, keep the value of K no larger than 50%. Otherwise, the braking resistor will overheat, which may cause a fire.

The braking frequency D is determined based on actual applications. "Table 4-22" on page 153 lists the typical values in common applications.

Table 4-22 Typical braking frequencies in different applications

Common Application	Elevator	Winding and Unwinding	Centrifuge	Occasional Braking Load	Regular Applications
Braking Frequency	20% to 30%	20% to 30%	50% to 60%	5%	10%

## Dimensions of braking units

The following figures show dimensions of two braking unit series.

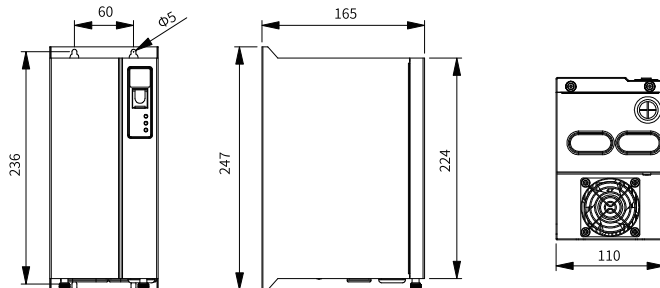

Figure 4-30 Dimensions of MDBUN series braking units (MDBUN-45-2T to MDBUN-90-2T; MDBUN-45-T to MDBUN-90-T; MDBUN-45-5T to MDBUN-90-5T) (mm)

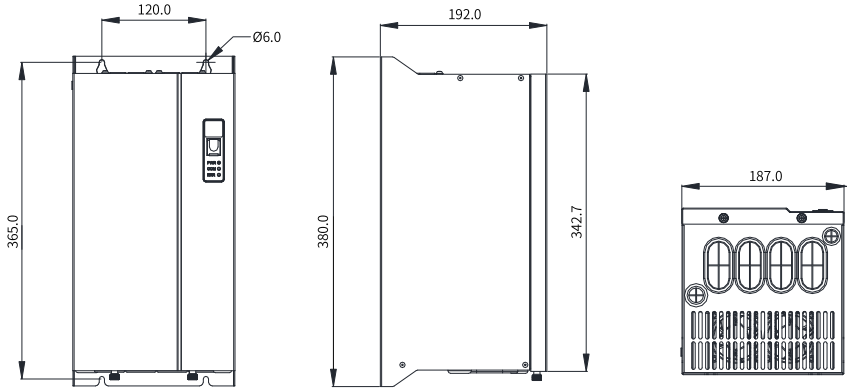

Figure 4-31 Dimensions of MDBUN series braking units (MDBUN-200-T, MDBUN-200-5T, MDBUN-200-7T) (mm)

## Braking unit models

---

### **Note**

The value in the table is obtained under working conditions featuring a braking usage ratio of 10% for heavy overload G-type equipment and a maximum braking time of 10s.

---

Table 4–23 Selection of braking components (three phase 380-480 V)

AC Drive Model	Braking unit		125% of Braking Torque (ED: 10% ; Max. 10s)		Remarks	Min. Braking Resistance (Ω)
	Model	Quantity	Recommended Braking Resistor Specification	Quantity of Braking Resistors		
MD580-4T2R1B	Built-in, standard		80 W, 1450 Ω	1	AC drive model with the model name containing B	96.0
MD580-4T3R1B			140 W, 800 Ω	1		96.0
MD580-4T3R8B			220 W, 500 Ω	1		96.0
MD580-4T5R1B			300 W, 380 Ω	1		96.0
MD580-4T7R2B			440 W, 260 Ω	1		64.0
MD580-4T9B			600 W, 190 Ω	1		64.0
MD580-4T13B			740 W, 150 Ω	1		32.0
MD580-4T17B			1100 W, 100 Ω	1		32.0
MD580-4T25B			1500 W, 75 Ω	1		32.0
MD580-4T32B			2200 W, 50 Ω	1		20.0
MD580-4T37B			3000 W, 38 Ω	1		20.0
MD580-4T45(B)			Built-in, optional			4000 W, 32 Ω
MD580-4T60(B)	4500 W, 27 Ω	1			24.0	
MD580-4T75(B)	6000 W, 20 Ω	1			19.2	
MD580-4T91(B)	7000 W, 16 Ω	1			14.8	
MD580-4T112(B)	9000 W, 13 Ω	1			12.8	
MD580-4T150(B)	11000 W, 10.5 Ω	1			9.6	
MD580-4T176(B)	15000 W, 7.7 Ω	1			6.8	
MD580-4T210	MDBUN-60-T	2	9000 W, 10.0 Ω	2	Input voltage ≤ 440 VAC	9.3 x 2
	MDBUN-60-5T	2	9000 W, 12.8 Ω	2	Input voltage > 440 VAC	11.4 x 2
MD580-4T253	MDBUN-90-T	2	11000 W, 8.0 Ω	2	Input voltage ≤ 440 VAC	6.8 x 2
	MDBUN-90-5T	2	11000 W, 10.5 Ω	2	Input voltage > 440 VAC	7.7 x 2
MD580-4T304	MDBUN-90-T	2	13000 W, 6.8 Ω	2	Input voltage ≤ 440 VAC	6.8 x 2
	MDBUN-90-5T	2	13000 W, 8.8 Ω	2	Input voltage > 440 VAC	7.7 x 2
MD580-4T377	MDBUN-200-T	2	16000 W, 2.8 Ω	2	Input voltage ≤ 440 VAC	2.5 x 2
	MDBUN-200-5T	2	16000 W, 3.6 Ω	2	Input voltage > 440 VAC	2.8 x 2
MD580-4T426(-L)	MDBUN-200-T	2	21000 W, 4.1 Ω	2	Input voltage ≤ 440 VAC	2.5 x 2
	MDBUN-200-5T	2	21000 W, 5.3 Ω	2	Input voltage > 440 VAC	3.0 x 2

AC Drive Model	Braking unit		125% of Braking Torque (ED: 10% ; Max. 10s)		Remarks	Min. Braking Resistance ( $\Omega$ )
	Model	Quantity	Recommended Braking Resistor Specification	Quantity of Braking Resistors		
MD580-4T465(-L)	MDBUN-200-T	2	27000 W, 3.2 $\Omega$	2	Input voltage $\leq$ 440 VAC	2.5 x 2
	MDBUN-200-5T	2	27000 W, 4.1 $\Omega$	2	Input voltage > 440 VAC	3.0 x 2
MD580-4T520(-L)	MDBUN-200-T	3	20000 W, 4.3 $\Omega$	3	Input voltage $\leq$ 440 VAC	2.5 x 3
	MDBUN-200-5T	3	20000 W, 5.5 $\Omega$	2	Input voltage > 440 VAC	3.0 x 3
MD580-4T585(-L)	MDBUN-200-T	3	28000 W, 3.8 $\Omega$	3	Input voltage $\leq$ 440 VAC	2.5 x 3
	MDBUN-200-5T	3	23000 W, 4.9 $\Omega$	2	Input voltage > 440 VAC	3.0 x 3
MD580-4T650(-L)	MDBUN-200-T	3	26000 W, 3.4 $\Omega$	3	Input voltage $\leq$ 440 VAC	2.5 x 3
	MDBUN-200-5T	3	26000 W, 4.3 $\Omega$	3	Input voltage > 440 VAC	3.0 x 3
MD580-4T725(-L)	MDBUN-200-T	3	29000 W, 3.0 $\Omega$	3	Input voltage $\leq$ 440 VAC	2.5 x 3
	MDBUN-200-5T	3	29000 W, 3.9 $\Omega$	3	Input voltage > 440 VAC	3.0 x 3
MD580-4T820(-L)	MDBUN-200-T	3	29000 W, 3.0 $\Omega$	3	Input voltage $\leq$ 440 VAC	2.5 x 3
	MDBUN-200-5T	3	29000 W, 3.9 $\Omega$	3	Input voltage > 440 VAC	3.0 x 3

**Note**  
For installation and use of MDBUN, see MDBUN Series Braking Unit User Guide.

### 4.3.6 AFE Unit

The active front end (AFE) is an optional unit used to feed the energy generated by the motor during braking back to the power grid. This eliminates the needs of the braking unit and braking resistor and reduces heat emission. Inovance AFE features energy efficiency, low noise, low harmonic, and high power factor.

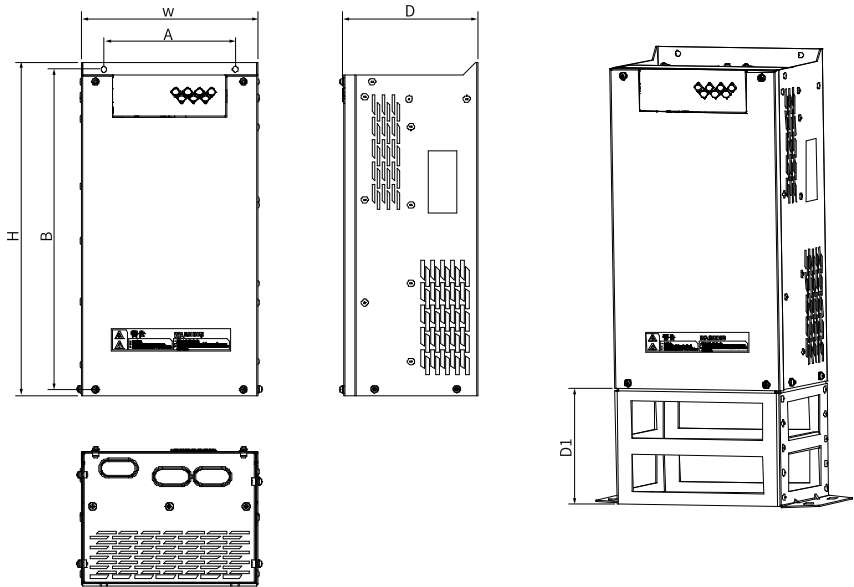

Figure 4-32 Dimensions of MD051 series AFE unit (unit: mm)

Table 4-24 Dimensions of MD051 series AFE unit

Model	Dimensions (mm)			Bracket D1	Mounting Hole Spacing (mm)		Mounting Hole Diameter (mm)	Weight (kg)
	H	W	D		A	B		
MD051T5.5G	365	200	153	121	160	350	6.0	8.5
MD051T7.5G								8.7
MD051T11G								9.0
MD051T15G	405	215	165	142	160	390	7.0	14.0
MD051T18.5G								14.8
MD051T22G	505	260	171	161	160	490	7.0	18.2
MD051T30G								20.0

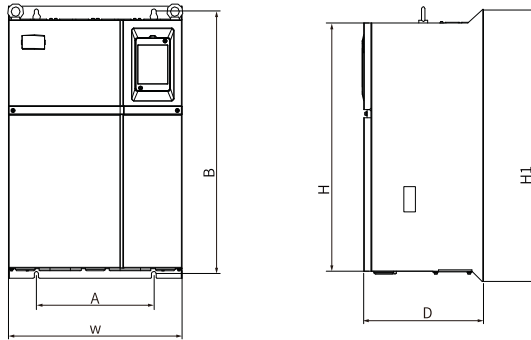

Figure 4-33 Dimensions of MD050 series AFE unit (unit: mm)

Table 4-25 Dimensions of MD050 series AFE unit

Model	Dimensions (mm)				Mounting Hole Spacing (mm)		Mounting Hole Diameter (mm)	Weight (kg)
	H	H1	W	D	A	B		
MD050-T37G	549	600	385	265	260	580	10	32
MD050-T45G								
MD050-T55G								
MD050-T75G	660	700	473	307	343	678	10	47
MD050-T90G								
MD050-T110G	880	930	579	380	449	903	10	90
MD050-T132G								
MD050-T160G								
MD050-T200G	983	1060	650	377	420	1030	12	130
MD050-T220G								
MD050-T250G								
MD050-T280G								
MD050-T315G	1203	1358	800	400	520	1300	14	200
MD050-T355G								
MD050-T400G								
MD050-T450G								

**Note**

For installation and use of the energy feedback unit, see *MD051 Series Active Front End (AFE) User Guide*.

### 4.3.7 Output Reactors

With an output reactor installed on the output side of the drive, the excessive  $dV/dt$  can be reduced, lowering the voltage stress on the motor winding. This protects the motor winding, lowers the motor temperature, and prolongs the service life of the motor.

Table 4-26 Minimum cable length when the output reactor is configured (three phase 380-480 V)

Drive Power (kW)	Rated Voltage (V)	Min. Cable Length for Optional Output Reactor (m)
0.4 to 3.0	200 to 500	50
3.7	200 to 500	50
5.5	200 to 500	70
7.5	200 to 500	100
11	200 to 500	110
15	200 to 500	125
18.5	200 to 500	135
22	200 to 500	150
$\geq 30$	280 to 690	150

Table 4-27 Minimum cable length when the output reactor is configured (three phase 200-240 V)

Drive Power (kW)	Rated Voltage (V)	Min. Cable Length for Optional Output Reactor (m)
0.4 to 3	200 to 500	50
3.7	200 to 500	70
5.5	200 to 500	110
7.5	200 to 500	125
$\geq 11$	200 to 500	150

### Models and dimensions (Inovance)

Models and dimensions of the recommended Inovance AC output reactors are as follows.

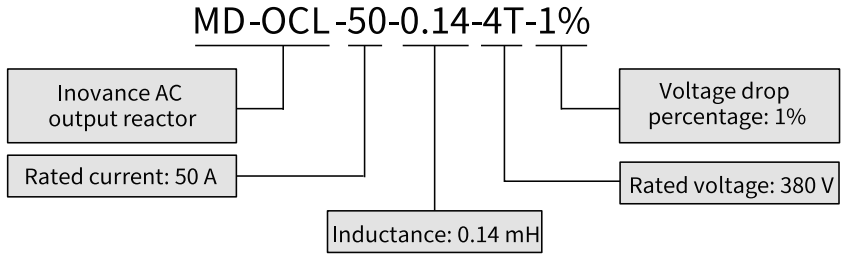

Figure 4-34 AC output reactor model

- The following recommended AC output reactors are applicable only to T1 to T9 models.
- For T10 to T12 models, purchase AC output reactors with the model name containing "-L".
- The T13 model is equipped with a built-in output reactor as standard.

Table 4–28 Selection of Inovance AC output reactors (three-phase 380 V to 480 V)

Structure	AC Drive Model	Reactor Model	Inductance (mH)	Loss (W)
T1	MD580-4T2R1B	MD-OCL-5-1.4-4T-1%	1.4	-
	MD580-4T3R1B	MD-OCL-5-1.4-4T-1%	1.4	-
	MD580-4T3R8B	MD-OCL-5-1.4-4T-1%	1.4	-
	MD580-4T5R1B	MD-OCL-7-1.0-4T-1%	1	-
	MD580-4T7R2B	MD-OCL-10-0.7-4T-1%	0.7	-
	MD580-4T9B	MD-OCL-10-0.7-4T-1%	0.7	-
T2	MD580-4T13B	MD-OCL-15-0.47-4T-1%	0.47	-
	MD580-4T17B	MD-OCL-20-0.35-4T-1%	0.35	-
T3	MD580-4T25B	MD-OCL-30-0.23-4T-1%	0.23	-
	MD580-4T32B	MD-OCL-40-0.18-4T-1%	0.18	-
T4	MD580-4T37B	MD-OCL-40-0.18-4T-1%	0.18	-
T5	MD580-4T45(B)	MD-OCL-50-0.14-4T-1%	0.14	-
	MD580-4T60(B)	MD-OCL-60-0.12-4T-1%	0.12	-
T6	MD580-4T75(B)	MD-OCL-80-0.087-4T-1%	0.087	-
	MD580-4T91(B)	MD-OCL-120-0.058-4T-1%	0.058	-
T7	MD580-4T112(B)	MD-OCL-120-0.058-4T-1%	0.058	-
	MD580-4T150(B)	MD-OCL-150-0.047-4T-1%	0.047	-
T8	MD580-4T176(B)	MD-OCL-200-0.035-4T-1%	0.035	-
	MD580-4T210	MD-OCL-250-0.028-4T-1%	0.028	-
	MD580-4T253	MD-OCL-330-0.021-4T-1%	0.021	-
T9	MD580-4T304	MD-OCL-330-0.021-4T-1%	0.021	-
	MD580-4T377	MD-OCL-490-0.014-4T-1%	0.014	-
T10	MD580-4T426	MD-OCL-490-0.014-4T-1%	0.014	-
	MD580-4T465	MD-OCL-490-0.014-4T-1%	0.014	-
T11	MD580-4T520	MD-OCL-660-0.011-4T-1%	0.011	-
	MD580-4T585	MD-OCL-660-0.011-4T-1%	0.011	-

Structure	AC Drive Model	Reactor Model	Inductance (mH)	Loss (W)
T12	MD580-4T650	MD-OCL-660-0.011-4T-1%	0.011	-
	MD580-4T725	MD-OCL-800-0.0087-4T-1%	0.0087	-
	MD580-4T820	MD-OCL-800-0.0087-4T-1%	0.0087	-

The following figure and table describe dimensions of the AC output reactor.

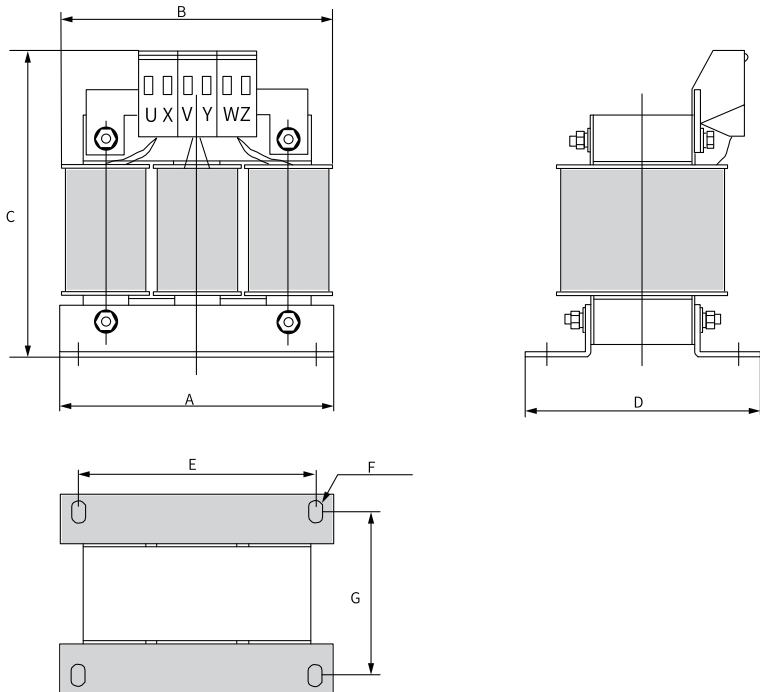

Figure 4-35 Dimensions of AC output reactors (5-10 A)

Table 4-29 Dimensions of AC output reactor (5-10 A, unit: mm)

Rated Current (A)	A	B	C	D	E	F	G
5	105±1	110	130	84±2	91±1	Φ6*11	65±2
7	105±1	110	130	84±2	91±1	Φ6*11	65±2
10	105±1	110	130	84±2	91±1	Φ6*11	65±2

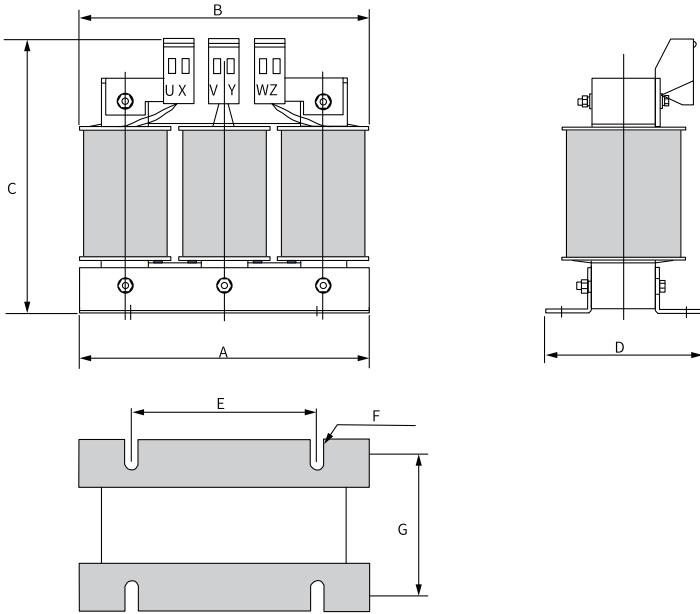

Figure 4-36 Dimensions of AC output reactors (15 A)

Table 4-30 Dimensions of AC output reactor (15 A, unit: mm)

Rated Current (A)	A	B	C	D	E	F	G
15	148±1	155	140	76±2	95±1	Φ6*15	61±2

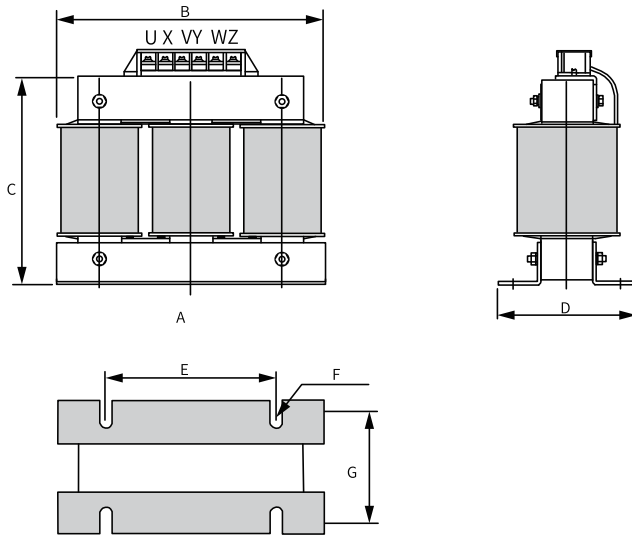

Figure 4-37 Dimensions of AC output reactors (20 A)

Table 4-31 Dimensions of AC output reactor (20 A, unit: mm)

Rated Current (A)	A	B	C	D	E	F	G
20	$148 \pm 1$	155	165	$76 \pm 2$	$95 \pm 1$	$\Phi 6 \times 15$	$61 \pm 2$

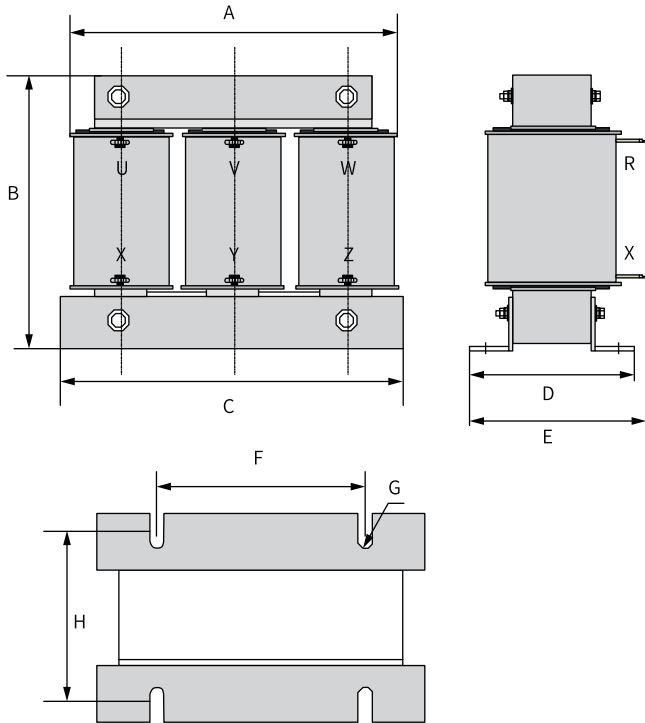

Figure 4-38 Dimensions of AC output reactors (30-60 A)

Table 4-32 Dimensions of AC output reactor (30-60 A, unit: mm)

Rated Current (A)	A	B	C	D	E	F	G	H
30	155	130	148±1	95±2	135	95±1	Φ6*15	80±2
40	155	130	148±1	95±2	135	95±1	Φ6*15	80±2
50	155	130	148±1	95±2	135	95±1	Φ6*15	80±2
60	195	165	188±1	92±2	130	120±1	Φ8.5*20	72±2

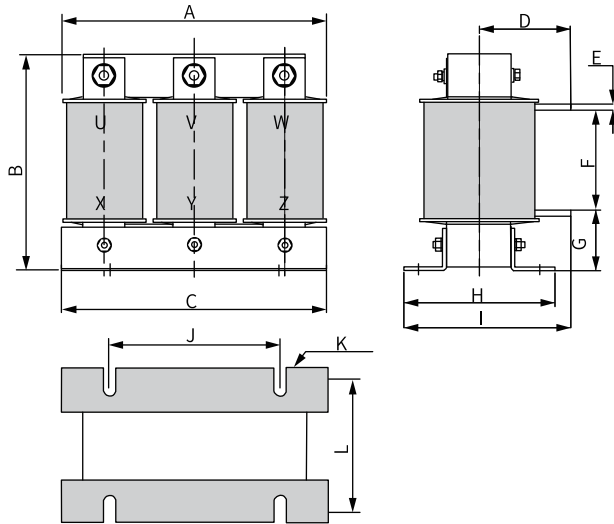

Figure 4-39 Dimensions of AC output reactors (80-120 A)

Table 4-33 Dimensions of AC output reactor (80-120 A, unit: mm)

Rated Current (A)	A	B	C	D	E	F	G	H	I	J	K	L
80	195	165	188±1	68±10	4	75±5	40±5	92±2	130	120±1	Φ8.5*20	72±2
90	195	165	188±1	68±10	4	75±5	40±5	92±2	130	120±1	Φ8.5*20	72±2
120	195	165	188±1	78±10	4	75±5	40±5	112±2	135	120±1	Φ8.5*20	72±2

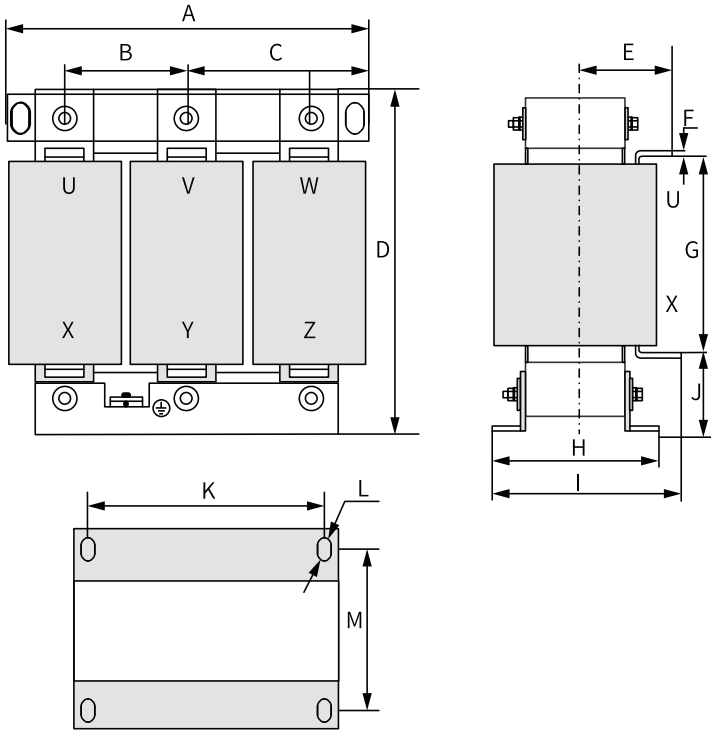

Figure 4-40 Dimensions of AC output reactors (150-250 A)

Table 4-34 Dimensions of AC output reactor (150-250 A, unit: mm)

Rated Current (A)	A	B	C	D	E	F	G	H	I	J	K	L	M
150	250	81±5	81±5	230	97±10	5	140±5	113±2	170	42±5	182±1	Φ11*18	87±2
200	250	81±5	81±5	230	102±10	5	140±5	123±2	175	42±5	182±1	Φ11*18	97±2
250	250	81±5	81±5	230	102±10	5	140±5	123±2	175	42±5	182±1	Φ11*18	97±2

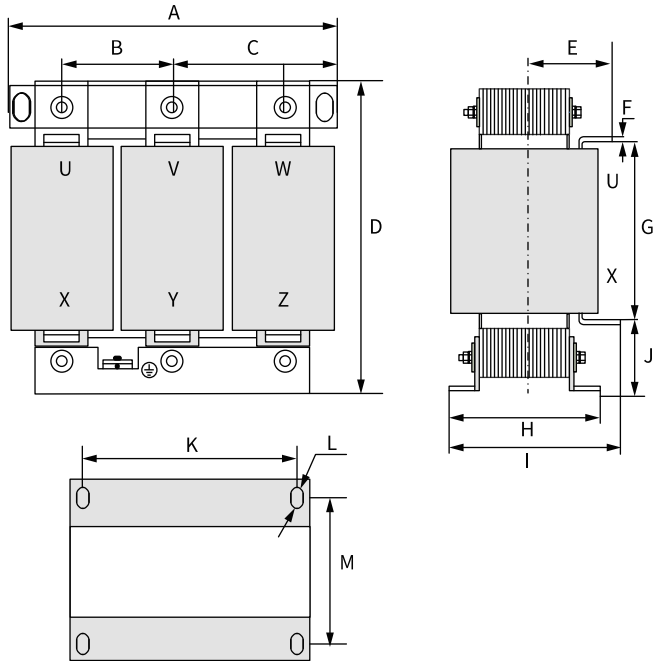

Figure 4-41 Dimensions of AC output reactors (330 A)

Table 4-35 Dimensions of AC output reactor (330 A, unit: mm)

Rated Current (A)	A	B	C	D	E	F	G	H	I	J	K	L	M
330	290	95±5	95±5	250	110±10	5	155±5	132±2	190	45±5	214±1	Φ11*18	106±2

### Models and dimensions (Schaffner)

Models and dimensions of the recommended Schaffner AC output reactors are as follows.

Table 4-36 Selection of output reactors (Schaffner)

Structure	AC Drive Model	Applicable Reactor	Inductance (mH)	Loss (W)
T1	MD580-4T2R1B	RWK 305-4-KL	1.47	22
	MD580-4T3R1B	RWK 305-4-KL	1.47	22
	MD580-4T3R8B	RWK 305-4-KL	1.47	22
	MD580-4T5R1B	RWK 305-7.8-KL	0.754	25
	MD580-4T7R2B	RWK 305-7.8-KL	0.754	25
	MD580-4T9B	RWK 305-10-KL	0.588	30
T2	MD580-4T13B	RWK 305-14-KL	0.42	34
	MD580-4T17B	RWK 305-17-KL	0.364	38
T3	MD580-4T25B	RWK 305-32-KL	0.184	55
	MD580-4T32B	RWK 305-32-KL	0.184	55
T4	MD580-4T37B	RWK 305-45-KL	0.131	60
T5	MD580-4T45(B)	RWK 305-45-KL	0.131	60
	MD580-4T60(B)	RWK 305-60-KL	0.098	65
T6	MD580-4T75(B)	RWK 305-90-KL	0.065	75
	MD580-4T91(B)	RWK 305-110-KL	0.053	90
T7	MD580-4T112(B)	RWK 305-124-KS	0.047	110
	MD580-4T150(B)	RWK 305-156-KS	0.038	120
T8	MD580-4T176(B)	RWK 305-182-KS	0.026	180
	MD580-4T210	RWK 305-230-KS	0.021	220
	MD580-4T253	RWK 305-280-KS	0.018	240
T9	MD580-4T304	RWK 305-330-KS	0.015	330
	MD580-4T377	RWK 305-400-S	0.012	340
T10	MD580-4T426	RWK 305-500-S	0.012	340
	MD580-4T465	RWK 305-500-S	0.01	380
T11	MD580-4T520	RWK 305-600-S	0.01	380
	MD580-4T585	RWK 305-600-S	0.009	410
T12	MD580-4T650	RWK 305-680-S	0.007	590
	MD580-4T725	RWK 305-790-S	0.006	740
	MD580-4T820	RWK 305-910-S	0.026	180

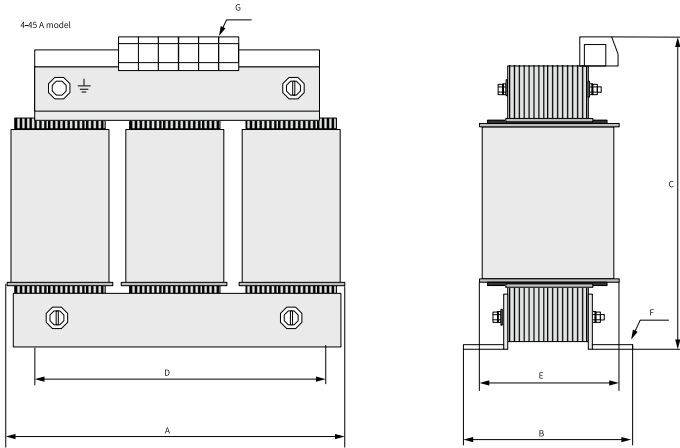

Figure 4-42 Dimensions of output reactors (4-45 A)

Table 4-37 Dimensions of output reactors (4-45 A, unit: mm)

Series	A	B	C	D	E	F	G
4 A and 7.8 A	100	Max. 60	Max. 115	56	34	4.8 x 9	2.5 mm <sup>2</sup>
10 A	100	Max. 70	Max. 115	56	43	4.8 x 9	2.5 mm <sup>2</sup>
14 A	125	Max. 70	Max. 135	100	45	5 x 8	2.5 mm <sup>2</sup>
17 A	125	Max. 75	Max. 135	100	55	5 x 8	2.5 mm <sup>2</sup>
24 A	125	Max. 75	Max. 135	100	55	5 x 8	4 mm <sup>2</sup>
32 A	155	Max. 95	Max. 170	130	56	8 x 12	10 mm <sup>2</sup>
45 A	155	Max. 110	Max. 190	130	72	8 x 12	10 mm <sup>2</sup>

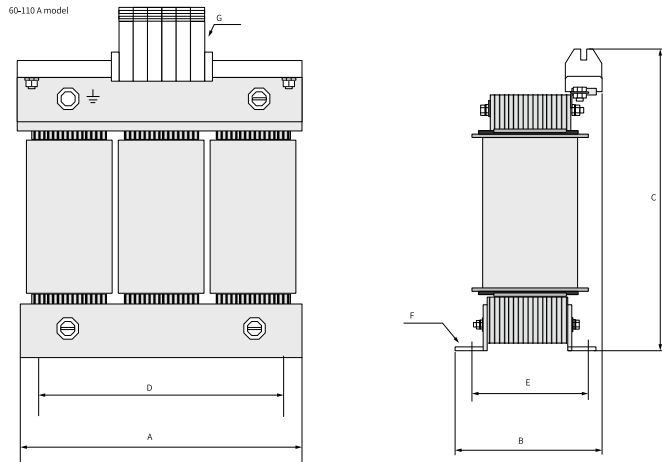

Figure 4-43 Dimensions of output reactors (60-110 A)

Table 4–38 Dimensions of the output reactor (60–110 A, unit: mm)

Series	A	B	C	D	E	F	G
60 A and 72 A	155	Max. 125	Max. 190	130	70	8 x 12	16 mm <sup>2</sup>
90 A	190	Max. 115	Max. 225	170	57	8 x 12	35 mm <sup>2</sup>
110 A	190	Max. 130	Max. 220	170	67	8 x 12	35 mm <sup>2</sup>

124-1100 A model

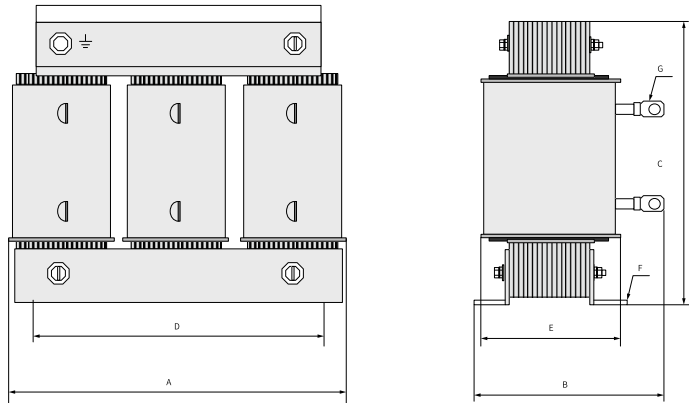

Figure 4-44 Dimensions of output reactors (124–1100 A)

Table 4–39 Dimensions of the output reactor (124–1100 A, unit: mm)

Series	A	B	C	D	E	F	G
124 A	190	Max. 180	Max. 160	170	67	8 x 12	Ø8
143 A	190	Max. 180	Max. 160	170	77	8 x 12	Ø8
156 A and 170 A	190	Max. 180	Max. 160	170	77	8 x 12	Ø10
182 A	210	Max. 180	Max. 185	175	97	8 x 12	Ø10
230 A	240	220	-	190	119	11 x 15	Ø12
280 A	240	235	-	190	133	11 x 15	Ø12
330 A	240	240	-	190	135	11 x 15	Ø12
400 A and 500 A	240	220	-	190	119	11 x 15	Ø11
600 A and 680 A	240	230	-	190	128	11 x 15	Ø11
790 A	300	218	-	240	136	11 x 15	Ø11
910 A	300	228	-	240	148	11 x 15	Ø11
1100 A	360	250	-	310	144	11 x 15	Ø11

### 4.3.8 Magnetic Ring and Magnetic Buckle

#### Model

Install the magnetic ring on the input or output side of the AC drive and as close to the AC drive as possible. Installing the magnetic ring on the input side suppresses noise in the power supply system of the AC drive. Installing the magnetic ring on the output side suppresses interference escaped from the AC drive to the outside and reduces the bearing current.

Use the magnetic ring or buckle in applications suffering current leakage and signal cable interference.

- Amorphous magnetic ring: featuring a high magnetic conductivity within the frequency band of 1 MHz and an excellent interference reduction performance, but not as low-cost as the magnetic buckle
- Ferrite magnetic buckle: featuring a good magnetic conductivity in frequency bands above 1 MHz and a good signal cable interference reduction performance in case of low-power AC drives

Table 4-40 Appearance and models of magnetic rings and buckles

Category	Model	Appearance
Magnetic ring	DY644020H	
	DY805020H	
	DY1207030H	
Magnetic buckle	DYR-130-B	

**Dimensions**

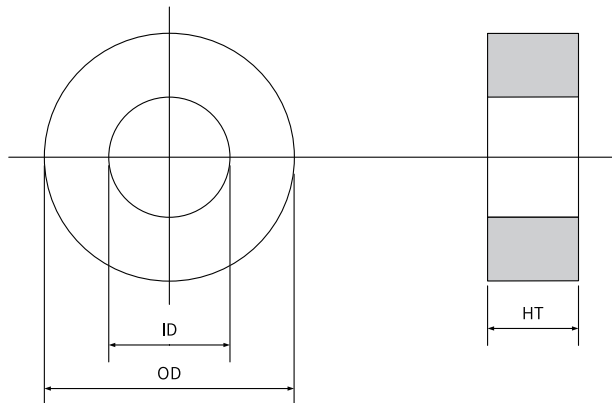

Figure 4-45 Dimensions of magnetic ring

Table 4-41 Dimensions of magnetic ring

Magnetic Ring Model	Dimensions (OD x ID x HT) (mm)
DY644020H	64 x 40 x 20
DY805020H	80 x 50 x 20
DY1207030H	120 x 70 x 30

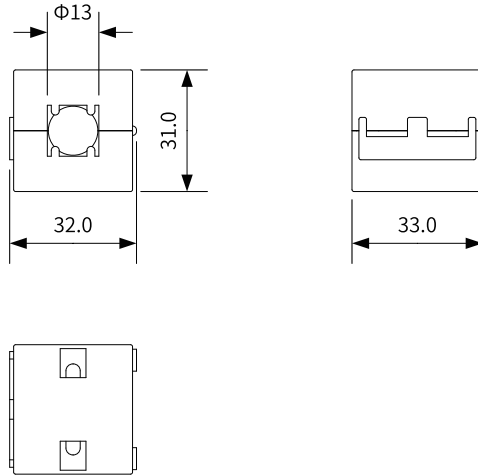



Figure 4-46 Dimensions of magnetic buckle

## 4.4 Operating Panel

Model	Description	Appearance
MDKE-10 LED	<p>An external LED operating panel adaptable to the MD580 series. It can be operated in the same way as the AC drive's operating panel, facilitating commissioning.</p> <p>For dimensions, see "<a href="#">Figure 4-47 Dimensions of MDKE-10 LED (unit: mm)</a>" on page 175.</p>	 <p>The MDKE-10 LED operating panel is a small, rectangular device with a monochrome LCD screen. The screen displays 'FWD' at the top left, a battery icon, and a green arrow icon at the top right. Below this, the word 'drive' is visible, followed by a large digital display showing '5000' and 'Hz' underneath. The panel features a central 'OK' button surrounded by four directional arrows (up, down, left, right). There are also two larger buttons on the sides, one green with a diamond icon and one red with a circle icon. At the bottom, there are two more buttons, one green and one red, with diamond and circle icons respectively.</p>
SOP-20-880 LCD	<p>An optional LCD operating panel that supports copy, download, and modification of parameters, which is easy to use. It displays parameters in Chinese.</p> <p>For dimensions, see "<a href="#">Figure 4-48 Dimensions of SOP-20-880 (unit: mm)</a>" on page 175.</p>	 <p>The SOP-20-880 LCD operating panel is a larger, black handheld device with a color LCD screen. The screen displays '1: Inverter' at the top. Below this, there is a list of menu items: '01 Parameters', '02 Fault Records', '03 Shortcut', and '04 Authority'. At the bottom of the screen, there are three buttons labeled 'Back', 'Loc 10:00:00', and 'Select'. The panel has a central navigation pad with a circular 'OK' button and four directional arrows. There are also two larger buttons on the sides, one green with a diamond icon and one red with a circle icon. At the bottom, there is a USB port and a 'Loc/Rem' button.</p>

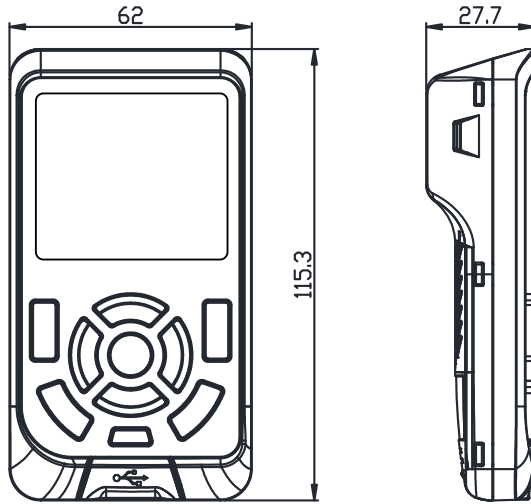

Figure 4-47 Dimensions of MDKE-10 LED (unit: mm)

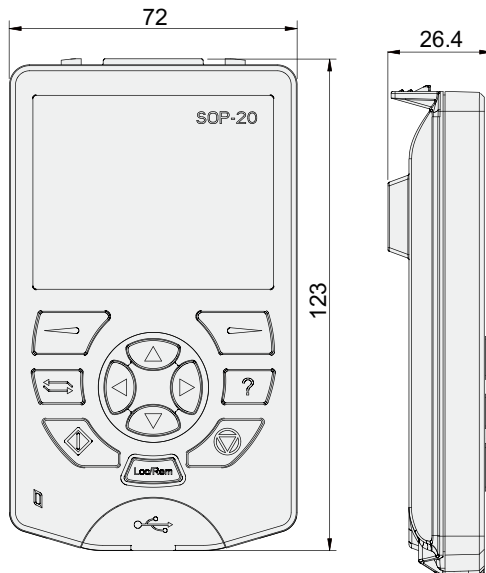

Figure 4-48 Dimensions of SOP-20-880 (unit: mm)

## 4.5 Expansion Card

### 4.5.1 List of Expansion Cards

The MD580 series AC drive supports multiple expansion cards to communicate with field buses. It also supports multiple encoder types for programming and secondary development. The functions and configurations of expansion cards are described in their user guides.

Table 4-42 Expansion cards

Name	Model	Description	Remarks
CANopen bus adapter card	MD580-SI-CAN1	CANopen communication adaption card	Available for all models
Modbus RTU bus adapter card	MD580-SI-RS1	Modbus RTU communication adaption card	Available for all models
PROFIBUS DP bus adapter	MD580-SI-DP1	PROFIBUS DP communication adaption card	Available for all models
PROFINET IO industrial Ethernet card	MD580-SI-PN1	PROFINET IO communication adaption card	Available for all models
Modbus TCP industrial Ethernet card	MD580-SI-EM1	Modbus TCP communication adaption card	Available for all models
EtherCAT communication card	MD580-SI-ECAT1	EtherCAT communication adapter card	Available for all models
EtherNet/IP industrial Ethernet card	MD580-SI-EN1	EtherNet/IP communication adaption card	Available for all models
Safe motor temperature detection card	MD580-HSMT-ATEX1	When the PTC in the motor is overheated, the detection card will disable the DO and activate the STO.	Applicable to T1-T3 models
	HSMT-10		Applicable to T4-T12 models
I/O expansion card	MD580-IO-RD1	It provides two AIs, two AOs, four DIs, and two ROs.	Available for all models
ABZ and SSI dual-encoder card	MD580-PG-AU1	Supports full closed-loop control; supports TTL level ABZ encoder and SSI encoder; provides the DB15 interface.	Available for all models
Sin-cos and SSI dual-encoder card	MD580-PG-AR1	Supports full closed-loop control; supports $\pm 1$ Vpp sin-cos encoder and SSI encoder; provides the DB15 interface.	Available for all models

Name	Model	Description	Remarks
Resolver interface card	MD38PG4	Applicable to the resolver; excitation frequency: 10 kHz; DB9 interface To meet the MD38PG4 requirements, the excitation input DC resistance of the resolver must be greater than 17 $\Omega$ . Failure to comply will result in MD38PG4 malfunction. Select a resolver with a maximum of four pole pairs. Otherwise, the MD38PG4 card will be overloaded.	Available for all models
MD38PGMD new multi-function encoder card	MD38PGMD	The card is an encoder interface card with the optional multiplied frequency division output function and supports 5 V or 15 V power supply. The card supports differential input, collector input, and push-pull input, as well as differential output and collector output; therefore, it can be used to connect to different encoders and supports A/B phase input of the host controller.	Available for all models

## 4.5.2 Expansion Card Installation

The AC drive is equipped with seven field bus cards (Modbus RTU, PROFIBUS DP, CANopen, PROFINET IO, Modbus TCP, EtherCAT, and Ethernet IP), one I/O expansion card, one explosion-proof card, and four PG cards. The installation positions are shown as follows. Before installing the expansion cards, remove the front cover of the AC drive.

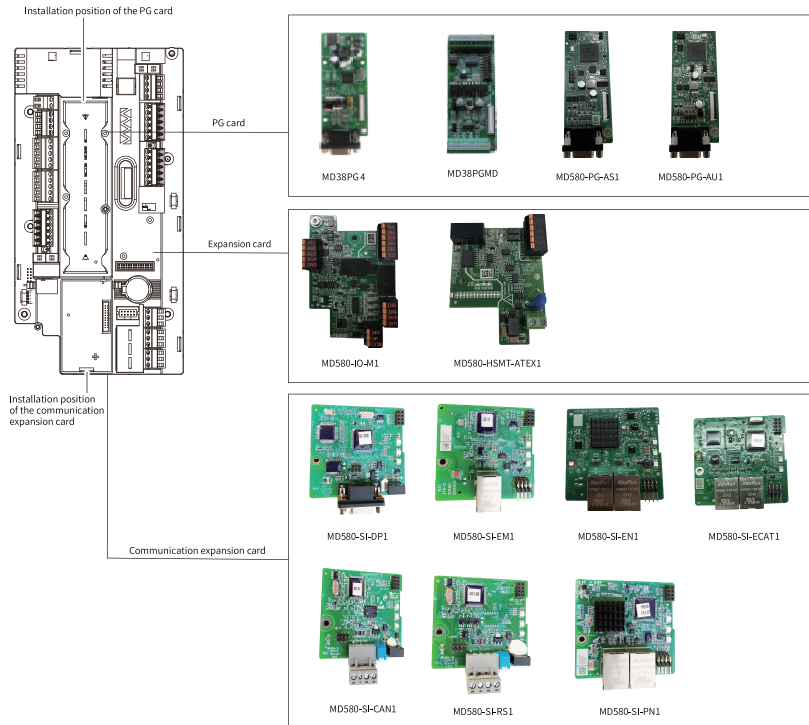

Figure 4-49 Installation positions of expansion cards

## 4.6 Safe Motor Temperature Detection Card

### Overview

The safe motor temperature detection card is used to sample safe motor temperature of the MD580 series (400 V and 690 V). Its safety level complies with the SIL2 standard. When the PTC in the motor is overheated, the MD580-HSMT-ATEX1/HSMT-10 card will disable the DO and activate the STO.

### Note

MD580-HSMTATEX1 is applicable to T1 to T3 models, and HSMT-10 is applicable to T4 to T12 models.

The product has the following features:

- It features the short circuit detection, overtemperature warning, and overtemperature protection functions.

- When short circuit or overtemperature occurs, the AC drive will be stopped.
- Compliance:
  - Device group II : Ground industrial product (excluding mining application)
  - Device category 2: The drive unit (or inverter) must be installed outside a potentially explosive atmosphere.
  - The motor can be used in the explosive environment with gas, steam, mist, or dust.

## Product information

HSMT-10  
①      ②

① <b>Product series</b> HSMT: Safe motor temperature detection card	④ <b>Voltage class</b> 10: Type 1
--	--------------------------------------

Table 4-43 Specifications

Item	Description
Operating ambient temperature	-10°C to +50°C
Storage temperature	-25°C to +70°C
Ambient humidity	5% to 95% RH, non-condensing
Working environment	Free from corrosive gases
Installation mode	Plug directly
IP rating	IP00
Pollution degree	PD2

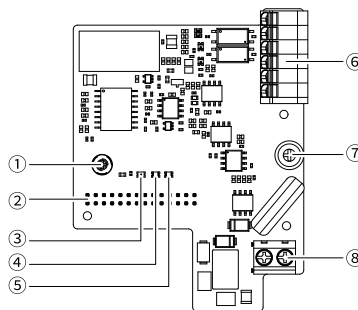

Figure 4-50 Components

No.	Name	Description
①	Fixing screw	It is used to fixed the card to the MD580.
②	J1 terminal	It is used for electrical connection with the MD580.
③	Over-temperature warning indicator	When the yellow indicator is on, the interior temperature of the motor is high. Keep a close observation.
④	Over-temperature indicator	When the red indicator is on, the motor interior is overheated. Check the motor temperature.
		When the red indicator is on, the PTC sampling terminal is not connected.
⑤	Short circuit indicator	When the red indicator is on, the PTC sampling circuit is short-circuited.
⑥	J3 terminal	STO 24 V DO
⑦	PE grounding screw	It is used to connect the card to the external and ensure proper PE grounding.
⑧	J2 terminal	PTC sampling terminal of the motor

## 4.7 I/O Card

### Overview

The MD580-IO-RD1 is an I/O expansion card of the MD580. The card provides two AIs, two AOs, four DIs, and two ROs. It is wired by using crimping terminals and is connected to the main control board by using the pin header. The card is also designed with reserved screw holes for fixing it to the plastic housing of the main control board and provides optional grounding screw.

## Product information

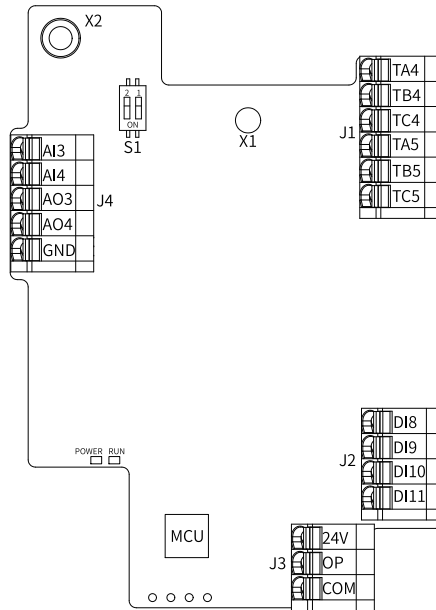

Figure 4-51 Layout of MD580-IO-RD1 terminals

Interface Name	Terminal Name	Description	Specification
J1	TA4	Common terminal	TA-TB: normally closed (NC); TA-TC: normally open (NO); contact capacity: 250 VAC/3 A (COS $\phi$ =0.4)
	TB4	NC terminal	
	TC4	NO terminal	
	TA5	Common terminal	
	TB5	NC terminal	
	TC5	NO terminal	
J2	DI8	DI	<ul style="list-style-type: none"> <li>• Ordinary DIs; high-speed pulse input not supported and photocoupler isolation supported; input frequency &lt; 100 Hz; compatible with bipolar input</li> <li>• Input impedance: &gt; 3.3 k<math>\Omega</math></li> <li>• Effective level input range: 9 V to 30 V</li> </ul>
	DI9	DI	
	DI10	DI	
	DI11	DI	

Interface Name	Terminal Name	Description	Specification
J3	24V	External 24 V power supply	-
	OP	Multi-functional input common terminal	The OP terminal is internally isolated from the COM and 24V terminals and short-circuited to the 24V terminal by a jumper by default.
	COM	24 V reference ground	-
J4	AI3	Analog input terminal 3	0 V to 10 V or 0 mA to 20 mA; 12-bit resolution; correction accuracy: 0.5%; input impedance in voltage input mode: 22.1 k $\Omega$ ; input impedance in current input mode: 500 $\Omega$ or 250 $\Omega$ ; voltage input mode by default. For details, see the function guide.
	AI4	Analog input terminal 4	
	AO3	Analog output terminal 3	<ul style="list-style-type: none"> <li>● 0 V to 10 V and 0 mA to 20 mA available; 12-bit resolution; correction accuracy: 1%; maximum load output current in voltage mode: 2 mA; load impedance in voltage mode: &gt; 5 k<math>\Omega</math>; load impedance in current mode: &lt; 500 <math>\Omega</math></li> <li>● To enable the current mode, set S1 to non-ON and configure through the software. For detailed software configurations, see the function guide.</li> <li>● To enable the voltage mode, set S1 to ON and configure through the software. For detailed software configurations, see the function guide.</li> </ul>
	AO4	Analog output terminal 4	
	GND	Analog reference ground	Internally isolated from COM
S1	AO mode selection	Voltage mode selection for AO3	1 set to ON: voltage mode enabled (default); 1 set to non-ON: current mode enabled
		Voltage mode selection for AO4	2 set to ON: voltage mode enabled (default); 2 set to non-ON: current mode enabled
LED	POWER	Power supply indicator	Off: The power supply is not connected.
	RUN	Operation indicator	<ul style="list-style-type: none"> <li>● Flashing quickly: The EEPROM is faulty.</li> <li>● Flashing slowly: Normal operation</li> <li>● Off: The program does not run.</li> </ul>

## Note

- The X1 screw is used for fixing, and X2 is an optional ground screw.
  - You can configure I/O expansion card-related parameters (such as parameters related to the correction function) in group F. For details, see the function guide. To distinguish the terminals on the I/O expansion card from those on the main control board, the terminals on the I/O expansion card are named following the terminal naming rule of the main control board. For example, if the main control board provides AI1 and AI2, the AI provided by the I/O expansion card will be named AI3.
  - To improve the anti-interference ability, you need to use a ground cable to connect the ground screw and the ground hole next to it.
- 

## 4.8 PG Card

### 4.8.1 ABZ Encoder

#### Overview

The MD38PGMD multi-function expansion card is optimized based on the MD38PG1, MD38PG5, and MD38PG6D cards. The MD38PGMD card supports differential input, collector input, push-pull input, as well as differential output and collector output; therefore, it can be used to connect to different encoders and supports A/B phase input of the host controller. Two models, MD38PGM and MD38PGMD, are available. The MD38PGMD features 64 (0-63) frequency division outputs, self-adaptive filtering, automatic interlock, etc., which can effectively solve application problems such as low upper limit of the host controller input frequency, strong field interference, and edge jitter of the encoder output signal.

## Product information

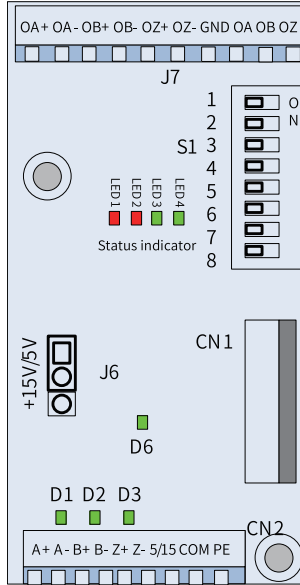

Figure 4-52 Layout of MD38PGMD terminals

Name	Description	Remarks
CN1	It connects the PG card and the control board of the drive.	-
CN2	It is the encoder signal input terminal supporting differential and collector input.	For details, see " <a href="#">Table 4-45 Pin definition of encoder signal input terminal CN2</a> " on page 185.
S1	It is the DIP switch used to select the frequency division coefficient and the filtering function.	-
J6	It is the jumper used to select the encoder power supply (5 V or 15 V).	By default, 5 V is selected.
J7	It is the frequency division output terminal supporting differential and collector output.	-
Status Indicator	LED1/LED2/LED3/LED4	For details, see "Status indicator".
D6	Power supply indicator	-
D1/D2/D3	They are the encoder input signal indicators, which flash or remain steady on when the PG card receives signals from the encoder.	D11 corresponds to A+/A-, D2 corresponds to B+/B-, and D3 corresponds to Z+/Z-.

Table 4–44 Specifications

Item	Description
Encoder power supply	5 V/200 mA; 15 V/100 mA
Max. input frequency	Differential: 500 kHz; collector: 100 kHz
Encoder interface type	Differential, collector, push-pull
Frequency division range	0 to 63
Type of frequency division interface	Differential, collector
Cable specification	16AWG to 26AWG. For details, see <i>MD38PGMD Multi-functional Encoder Expansion Card User Guide</i> .
Terminal clearance	3.5 mm
Terminal screw	Slotted
Terminal type	Inclined terminal block

Table 4–45 Pin definition of encoder signal input terminal CN2

Pin No.	1	2	3	4	5	6	7	8	9
Terminal Name	A+	A-	B+	B-	Z+	Z-	5V/15V	COM	PE
Description	Encoder output signal A (+)	Encoder output signal A (-)	Encoder output signal B (+)	Encoder output signal B (-)	Encoder output signal Z (+)	Encoder output signal Z (-)	Encoder power supply 5 V/15 V	Encoder power supply ground	Shield connection terminal

Table 4–46 Pin definition of frequency division output signal terminal J7

Pin No.	1	2	3	4	5	6	7	8	9	10
Name	OA+	OA-	OB+	OB-	OZ+	OZ-	GND	OA	OB	OZ
Description	Signal A (+) for differential frequency division output	Signal A (-) for differential frequency division output	Signal B (+) for differential frequency division output	Signal B (-) for differential frequency division output	Signal Z (+) for differential frequency division output	Signal Z (-) for differential frequency division output	Frequency division reference ground	Signal A for collector frequency division output	Signal B for collector frequency division output	Signal Z for collector frequency division output

The DIP switch S1 is used to set the frequency division coefficient and select the filtering function. The code is 1 when the DIP switch is ON; otherwise, the code is 0. See the following table.

Table 4-47 Pin definition of encoder signal input terminal CN2

Frequency Division Coefficient	DIP switch								Filtering
	Switch for Setting Frequency Division Coefficient						Switch for Setting the Filtering Function		
	1	2	3	4	5	6	7	8	
No output	0	0	0	0	0	0	0	0	Non-adaptive filtering
Frequency division output 1	1	0	0	0	0	0			
Frequency division output 2	0	1	0	0	0	0	1	0	Adaptive filtering
Frequency division output 3	1	1	0	0	0	0			
—	—	—	—	—	—	—	0	1	Fixed interlock
—	—	—	—	—	—	—			
—	—	—	—	—	—	—			
Frequency division output 63	1	1	1	1	1	1	1	1	Automatic interlock

## Note

- Non-adaptive filtering: The filter coefficient of the PG card is fixed and small. It is applicable to the environment with no or weak interference or high speed applications.
  - Adaptive filtering: The filter coefficient of the PG card is automatically adjusted. Therefore, the PG card features strong anti-interference abilities, especially when the feedback speed of the encoder is lower than 100 kHz. This mode applies to scenarios with strong interference. It is the default mode.
  - Fixed interlock: When the PG card is set to this mode, it has all functions when set to adaptive filtering. In addition, in this mode, the PG card also features edge jitter elimination of the encoder feedback signal. This mode applies to scenarios where edge jitter exists in the encoder feedback signal.
  - Automatic interlock: When the PG card is set to this mode, it has all functions when set to fixed interlock. In addition, the PG card can switch between the adaptive filtering mode and the fixed interlock mode. This can meet requirements of zero-speed running and non-zero-speed running, and prevent useful signals from being cleared as edge jitter during zero speed running in the fixed interlock mode.
-

Table 4-48 Status indicator

Type	Number	State	Description
Encoder input signal quality indicator (red)	LED1	Off	The input signal is normal, the speed is stable, or there is no interference.
		Solid on	The input signal is slightly unstable, which occurs when the motor accelerates or decelerates or when the encoder input signal is slightly interfered with.
		Flashing slowly <sup>&lt;1&gt;</sup>	The input signal is moderately unstable, which occurs when the motor accelerates or decelerates or when the encoder input signal is moderately interfered with.
		Flashing quickly <sup>&lt;1&gt;</sup>	The input signal is seriously unstable, which occurs when the motor accelerates or decelerates rapidly or when the encoder input signal is seriously interfered with.
PG card signal processing quality indicator (red)	LED2	Off	The PG card signal is normal, the speed is stable, or there is no interference.
		Solid on	The PG card signal is slightly unstable, which occurs when the motor accelerates or decelerates or when the number of interference pulses that are not filtered by the PG card is less than 10 per time unit.
		Flashing slowly	The PG card signal is moderately instable, which occurs when the motor accelerates or decelerates or when the number of interference pulses that are not filtered by the PG card is less than 30 per time unit.
		Flashing quickly	The PG card signal is seriously instable, which occurs when the motor accelerates or decelerates or when the number of interference pulses that are not filtered by the PG card is larger than 30 per time unit.
Interlock state indicator (green)	LED3	Solid on	The interlock function is enabled.
		Off	The interlock function is disabled.
System state indicator	LED4	Solid on	The system is working normally.
		Flashing	The encoder cable breaks.

## Note

<1>: The slow flashing frequency is 2 Hz and the quick flashing frequency is 10 Hz.

## 4.8.2 Resolver Encoder Card

### Overview

The MD38PG4 resolver transformer expansion card (hereinafter referred to as resolver expansion card) is a card independently developed and produced by Inovance for information acquisition. Generally, it is used with AC drives of Inovance. The PG expansion interface of the MD580 supports the resolver expansion card. It mainly collects the position and speed signal fed back by the resolver transformer on the motor side to enable the drive to accurately control the motor position and speed. The card is small in size and easy to install. It can adapt to harsh environment such as strong vibration, high pollution, and high temperature.

### Product information

Table 4-49 Specifications

User Interface	Hot Plug	Cable Specification	Resolution	Excitation Frequency	V <sub>RMS</sub>	V <sub>pp</sub>	Frequency Division Range
DB9 (female)	Supported	< 22AWG	12-bit	10 kHz	7 V	15±27%	Without frequency division

Table 4-50 Terminal function description

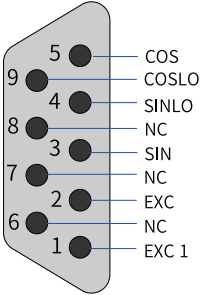
Terminal Silk screen	Pin No.	Pin Assignment	Function	Terminal Drawing
DB9	1	EXC1	Resolver excitation (-)	
	2	EXC	Resolver excitation (+)	
	3	SIN	Resolver feedback SIN (+)	
	4	SINLO	Resolver feedback SIN (-)	
	5	COS	Resolver feedback COS (+)	
	6, 7, 8	N/C	Unconnected internally	
	9	COSLO	Resolver feedback COS (-)	
CN1	18-pin flexible flat cable (FFC) interface, which is used to connect to the PG card slot on the control board of the AC drive.			

### 4.8.3 Sin-Cos and SSI Dual-Encoder Expansion Card

#### Overview

The sin-cos and SSI dual-encoder card (MD580-PG-AS1) is an expansion card that supports fully closed-loop control scenarios. The card is connected to the control board by using the FPC flat cable, and provides the universal DB15 connector which requires the DB15 male connector customized according to pin sequences defined in the user guide. The sin-cos encoder is used to detect the sin-cos signal input of the incremental encoder, and the SSI encoder is used to detect the signal input of the absolute encoder adopting the universal serial port protocol. The interface can support power supplies of 5 V, 12 V and 24 V for encoders.

## Product information

Table 4-51 Terminals

Type	Terminal Name	Description	Pin No.	Terminal Drawing
Sin-cos and SSI dual-encoder expansion card	Z+	Z signal of the incremental encoder (+)	3	
	Z-	Z signal of the incremental encoder (-)	8	
	SIN+	SIN signal of the incremental encoder (+)	1	
	SIN-	SIN signal of the incremental encoder (-)	6	
	COS+	COS signal of the incremental encoder (+)	2	
	COS-	COS signal of the incremental encoder (-)	7	
	12V	12 V power supply of the encoder	14	
	COM	Encoder power supply grounding	15	
	DATA+	DATA signal of the SSI encoder (+)	4	
	DATA-	DATA signal of the SSI encoder (-)	9	
	5V	5 V power supply of the encoder	11	
	COM	Encoder power supply grounding	12	
	24V	24 V power supply of the encoder	13	
	CLK+	Clock output signal of the SSI encoder (+)	5	
	CLK-	Clock output signal of the SSI encoder (-)	10	

Table 4–52 Specifications

Item	Description
5 V power supply of the encoder	5 V/300 mA
Sin-cos signal	Differential voltage: 0.6-1.2 Vpp; typical value: 1.0 Vpp
	Maximum common mode voltage: 3 V
	Bandwidth: 300 kHz

Table 4–53 Description of status indicators

Name	Status	Description
Fault indicator	Red	The sin-cos encoder is faulty (UART communication timeout, UART communication frame error, or CRC error).
	Yellow	The SSI encoder is faulty (frame error or invalid data).
	Green	Normal
Communication status indicator	Red	SPI communication fault (CRC fault or PG card not activated)
	Green	Communication normal
	Yellow	Reserved

## 4.8.4 ABZ and SSI Dual-Encoder Expansion Card

### Overview

The ABZ and SSI dual-encoder card is an expansion card that supports fully closed-loop control scenarios. The card is connected to the control board by using the FPC flat cable, and provides the universal DB15 connector which requires the DB15 male connector customized according to pin sequences defined in the user guide. The ABZ encoder is used to detect the signal input of TTL or RS422 incremental encoders, and the SSI encoder is used to detect the signal input of the absolute encoder adopting the universal serial port protocol. The interface can support power supplies of 5 V, 12 V and 24 V for encoders.

Features:

- ABZ encoder
  - Supports signal detection of the incremental encoder: A+, A-, B+, B-, Z+, and Z-.
  - Several types of power supplies available: 5.2 VDC $\pm$ 5%, 300 mA; 12 VDC $\pm$ 10%, 300 mA; 24 VDC $\pm$ 10%, 100 mA
  - Supports TTL differential signal input and RS422 signal input.
  - Provides the signal cable disconnection detection function.
  - Equipped with functions such as adaptive filtering and orthogonal interlock to improve the detection stability of the module.

- Powered by the PG card slot without the external power supply required
- SSI encoder
  - Supports signal detection of RS422 absolute encoder.
  - Supports disconnection detection, communication detection, and fault display functions.
  - Powered by the PG card slot without the external power supply required.  
Several types of power supplies available: 5.2 VDC $\pm$ 5%, 200 mA; 12 VDC $\pm$ 10%, 300 mA; 24 VDC $\pm$ 10%, 100mA.

## Product Information

Type	Terminal Name	Description	Pin No.	Terminal Drawing
ABZ+SSI card	Z+	Positive Z signal of the incremental encoder	3	
	Z-	Negative Z signal of the incremental encoder	8	
	A+	Positive A signal of the incremental encoder	1	
	A-	Negative A signal of the incremental encoder	6	
	B+	Positive B signal of the incremental encoder	2	
	B-	Negative B signal of the incremental encoder	7	
	12V	12 V power supply for the encoder	14	
	COM	Encoder power supply grounding	15	
	DATA+	Positive data signal of the SSI encoder	4	
	DATA-	Negative data signal of the SSI encoder	9	
	5V	5 V power supply for the encoder	11	
	COM	Encoder power supply grounding	12	
	24V	24 V power supply for the encoder	13	
	CLK+	Positive clock output signal of the SSI encoder	5	
	CLK-	Negative clock output signal of the SSI encoder	10	

Table 4–54 Description of status indicators

Name	Status	Description
Fault indicator	Red	The ABZ encoder is faulty (disconnection).
	Yellow	The SSI encoder is faulty (frame error or invalid data).
	Green	The ABZ and SSI encoders are normal.
Communication status indicator	Red	SPI communication fault (CRC fault or PG card not activated)
	Green	Communication normal
	Yellow	Reserved

Table 4–55 Specifications

Item	ABZ	SSI
Encoder power supply	5 VDC $\pm$ 5%, 500 mA; 12 VDC $\pm$ 10%, 300 mA; 24 VDC $\pm$ 10%, 100 mA	
Encoder input signal	Differential TTL or RS422 incremental signal	RS422 absolute signal
Signal maximum input frequency	500 kHz	1 MHz
Disconnection detection	Supported	Supported
Encoder resolution	-	32-bit

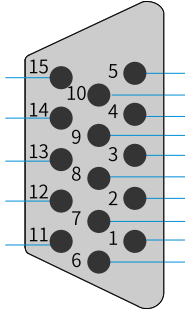
## 5 Routine Maintenance and Repair

### 5.1 Routine Maintenance Checklist

Check the following items daily to avoid deterioration in performance or product damage. Print the checklist and sign the "Checked" column after each inspection.

Item	Content	Solution	Checked
Motor	Check whether abnormal sounds and vibration occur on the motor.	<ul style="list-style-type: none"> <li>● Check the mechanical connections.</li> <li>● Check output phase loss of the motor.</li> <li>● Confirm that the retaining screws of the motor are tightened.</li> </ul>	
Fan	Check whether the cooling fan of the AC drive and motor work normally.	<ul style="list-style-type: none"> <li>● Check the operation of the cooling fan of the AC drive.</li> <li>● Check the operation of the cooling fan of the motor.</li> <li>● Confirm that the air filter is not clogged.</li> <li>● Confirm that the ambient temperature is within the allowed range.</li> </ul>	
Installation environment	Check whether the cabinet and cable duct are normal.	<ul style="list-style-type: none"> <li>● Confirm that input and output cables do not have damaged insulation.</li> <li>● Confirm that no vibration occurs on the hanging bracket.</li> <li>● Confirm that the copper bars and terminals are not loose or corroded.</li> </ul>	
Load	Check whether the operation current of the AC drive exceeds the rated current of the AC drive and motor for a certain period.	<ul style="list-style-type: none"> <li>● Confirm that motor parameters are set properly.</li> <li>● Confirm that the motor is not overloaded.</li> <li>● Confirm that the mechanical vibration is not too large (&lt; 1G under normal conditions).</li> </ul>	
Input voltage	Check whether the voltage of the main circuit power supply and the control circuit power supply is normal.	<ul style="list-style-type: none"> <li>● Confirm that the input voltage is within the allowed range.</li> <li>● Confirm that no heavy load exists around.</li> </ul>	

## 5.2 Periodic Inspection Checklist

Item	Content	Solution	Checked
Whole machine	Check whether wastes, dirt, and dust exist on the surface.	<ul style="list-style-type: none"> <li>● Confirm that the cabinet of the AC drive is not powered off.</li> <li>● Use a vacuum cleaner to suck up wastes and dust to prevent direct touching.</li> <li>● Wipe stubborn stains with alcohol and do not operate the AC drive until the alcohol completely evaporates.</li> </ul>	
Cable	Check whether power cables and connections are discolored. Confirm that the insulation layer is not aged or cracked.	<ul style="list-style-type: none"> <li>● Replace cracked cables.</li> <li>● Replace damaged terminals.</li> </ul>	
Peripheral devices such as electromagnetic contactor	Check whether the contactor is loose or abnormal noise exists during operation. Check whether short-circuit, water stain, dilation, or cracking exists on peripheral devices.	<ul style="list-style-type: none"> <li>● Replace abnormal peripheral devices.</li> </ul>	
Ventilation	Check whether the air filter and heatsink are clogged. Check whether the fan is damaged.	<ul style="list-style-type: none"> <li>● Clean the air filter.</li> <li>● Replace the fan.</li> </ul>	
Control circuit	Check whether control components have fine contact. Check whether the terminal screws are loose. Check whether control cables have cracked insulation.	<ul style="list-style-type: none"> <li>● Clear away foreign matters on the surface of control cables and terminals.</li> <li>● Replace damaged or corroded control cables.</li> </ul>	

## 5.3 Replacement of Quick-Wear Parts

### 5.3.1 Service Life of Quick-Wear Parts

Quick-wear parts of the AC drive include the cooling fan and filter electrolytic capacitor. Their lifetime is related to the operating environment and maintenance. Generally, the service life is as follows.

Component Name	Service Life <sup>[Note]</sup>
Fan	≥ 5 years
Electrolytic capacitor	≥ 5 years

 **Caution**

The standard lifetime indicates the lifetime when the components are used in the following conditions. You can determine when to replace these components according to the actual operating time.

- Ambient temperature: 40°C
- Load rate: 80%
- Operating rate: 24 hours per day

### 5.3.2 Replacing the Fan

1. Possible damage cause: bearing wear and blade aging
2. Judging criteria: blade crack, abnormal vibration noise upon startup, and blade operation abnormality
3. Replacement:
  - To remove the fan, press the snap-fit joint on the fan protective plastic cover and pull the fan outward.
  - After replacing the fan, ensure the fan blows the air upwards.

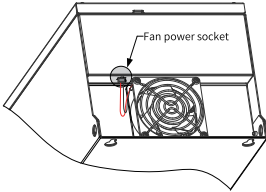
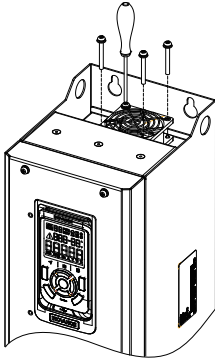
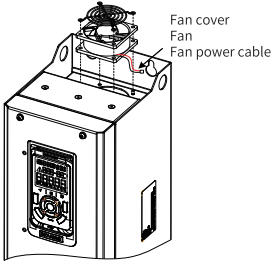
Removing the Fan (MD580-4T2R1B to MD580-4T377)		
<p>① Disconnect the power supply cable plug of the fan from the socket (top view).</p> 	<p>② Remove the four screws on the fan cover with a screwdriver.</p> 	<p>③ Remove the fan cover and fan from the drive.</p> 

Installing the Fan (MD580-4T2R1B to MD580-4T377)

- ① Install the fan in a reverse procedure to removal. Ensure the correct direction of the fan.
- ② Install the fan and fan cover into the AC drive. Align the mounting holes of the cooling fan with the mounting holes of the AC drive, as shown by the dotted line in figure ③ of the removal procedure.
- ③ After replacing the fan, ensure the fan blows the air upwards.

Ensure that the fan blows upwards.

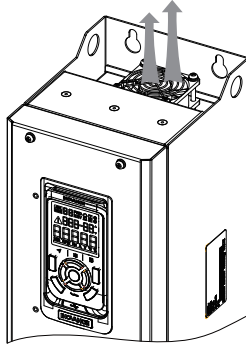

Removing the Fan (MD580-4T426(-L) to MD580-4T820(-L))

- ① Remove the six screws on the cover. Then, hold the cover with both hands and lift it up in the arrow direction shown below to remove the cover.
- ② Disconnect the fan power cable connectors from the AC drive. Each fan has a power cable connector.
- ③ Remove screws from the fan box and draw the fan box out in the arrow direction.
- ④ Remove the screws from each fan cover and remove the fans.

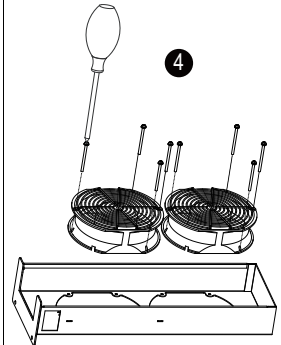
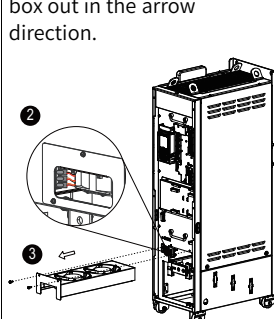
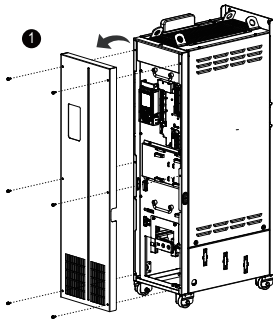

Installing the Fan (MD580-4T426(-L)–MD580-4T820(-L))

- ① Install the fan in a reverse procedure to removal. Ensure the correct direction of the fan.
- ② Align the fan box to the mounting rail and push it into the AC drive.
- ③ Connect the fan power cable connectors first before fixing the fan box. After replacing the fan, ensure the fan blows the air upwards.

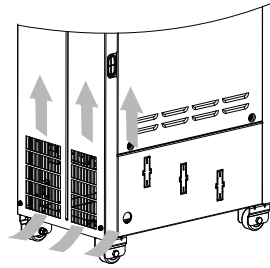
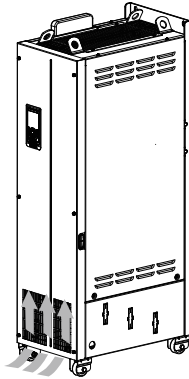

## 5.4 Storage

For storage of the AC drive, observe the following:

- To store the drive, pack the AC drive with the original packing box provided by Inovance.
- Do not expose the drive to the environment with moisture or high temperature, or place it outdoors in direct sunlight for an extended period.
- The electrolytic capacitor will deteriorate after being stored for a long time. Therefore, the AC drive must be switched on once for at least five hours every six months. The input voltage must be increased slowly to the rated value by using a voltage regulator. Contact professionals for technical support if necessary.

## 6 Compliance List

### 6.1 Compliance List

The following table lists related certifications, directives, and standards. Certification marks on the product nameplate indicate the certifications acquired.

Certification Name	Directive Name		Standard
CE certification	EMC directive	2014/30/EU	EN IEC 61800-3
	LVD directive	2014/35/EU	EN 61800-5-1
	RoHS directive	2011/65/EU	EN 50581

### Note

The CE certification of the product conforms to the latest versions of the above-mentioned directives and standards.

### 6.2 CE Certification

#### 6.2.1 Precautions for Compliance with European Standards



Figure 6-1 CE mark

- The CE mark is required for commercial trades (including manufacture, import, and sales) in Europe to indicate compliance with the directives for safety (LVD), electromagnetic compatibility (EMC), and environmental protection (RoHS).
- Products traded (including manufacture, import, and sales) in Europe must bear the CE mark.
- This product conforms to the LVD, EMC Directive, and RoHS Directive, and is therefore marked with CE.
- Machinery and devices equipped with this product must also meet CE standards when sold in Europe.
- Customers who integrate this product with other devices have the responsibility of ensuring compliance with CE standards when the CE mark is labeled on the final device.

## 6.2.2 Conditions for Compliance with the EMC Directive

- This product satisfies the European EMC directive 2014/30/EU and the EN 61800-3 standard, and is applicable to both the first environment and the second environment.



When used in the first environment, the equipment may generate radio interference. Except that the equipment must confirm to requirements of CE certifications, you also need to take measures to prevent radio interference if required.

---

- To satisfy the EMC directive and standard, install an EMC filter on the input side of the product, select a recommended shielded cable for the output side, ground the filter reliably, and ensure all-round connection of the shield of the output cable.



Manufacturers of systems integrating with this product are responsible for system compliance with the European EMC directive and EN IEC 61800-3 requirements in different system application environments.

---

## Introduction to EMC Standard

Electromagnetic compatibility (EMC) describes the ability of electronic and electrical devices to work properly in the electromagnetic environment and not to generate electromagnetic interference that influences nearby devices or systems. Therefore, EMC includes the following requirements:

- The electromagnetic interference generated by a device during normal operation must be restricted within a certain limit.
- A device or system must have sufficient immunity to electromagnetic interference in the environment. This involves electromagnetic susceptibility.

EN IEC 61800-3 defines the following two environments:

- First environment: This includes domestic premises, and establishments directly connected to a low-voltage power supply network which supplies power to buildings used for domestic purposes.
- Second environment: This includes all establishments other than those directly connected to a low-voltage power supply network which supplies power to buildings used for domestic purposes.

Based on the expected use environment, the products are divided into the following four categories:

- Category C1: power drive system (PDS) of rated voltage below 1000 V, intended for use in the first environment
- Category C2: PDS of rated voltage below 1000 V, which is neither a plug-in device nor a removable device and, when used in the first environment, is intended to be installed and commissioned only by a professional person
- Category C3: PDS of rated voltage below 1000 V, intended for use in the second environment and not intended for use in the first environment
- Category C4: PDS of rated voltage equal to or above 1000 V, or rated current equal to or above 400 A, or intended for use in complex systems in the second environment

### 6.2.3 Conditions for Compliance with the LVD

This product has been tested according to EN61800-5-1, and it complies with the Low Voltage Directive (LVD) completely. Observe the following requirements to enable machines and devices integrated with this drive to comply with LVD.

#### Installation location

Install this product in a place with the pollution degree of 2 or below and overvoltage category III as specified in IEC 60664-1.

#### Installation environment

For requirements of installation environment, see "Environment" in *MD580 Series Low-Voltage High-Performance Engineering AC Drive Installation Guide*.

#### Requirements on installation and protection

- This product must be installed in a fireproof cabinet as part of a final system that is provided with effective electrical and mechanical protection. The installation must conform to local and regional laws and regulations, and to relevant IEC requirements.
- For a cabinet-mounted AC drive (IP20), install it in structures that cannot be accessed by foreign objects from the top and front.

#### Main circuit wiring requirements

For wiring requirements of main circuit terminals, see "Main Circuit Wiring Requirements" in *MD580 Series Low-Voltage High-Performance Engineering AC Drive Installation Guide*.

#### Requirements on protective devices

To meet the requirements of EN 61800-5-1, a fuse/circuit breaker must be connected on the input side to prevent accidents caused by internal short circuits. Use a fuse

that matches the maximum input current of the AC drive. For selection of fuses, see ["4.3.1 Fuse, Contactor, and Circuit Breaker" on page 128.](#)



19011706A02

---

Copyright © Shenzhen Inovance Technology Co., Ltd.

---

**Shenzhen Inovance Technology Co., Ltd.**

[www.inovance.com](http://www.inovance.com)

---

**Add.:** Inovance Headquarters Tower, High-tech Industrial Park,  
Guanlan Street, Longhua New District, Shenzhen

**Tel:** (0755) 2979 9595

**Fax:** (0755) 2961 9897

---

**Suzhou Inovance Technology Co., Ltd.**

[www.inovance.com](http://www.inovance.com)

---

**Add.:** No. 16 Youxiang Road, Yuexi Town,  
Wuzhong District, Suzhou 215104, P.R. China

**Tel:** (0512) 6637 6666

**Fax:** (0512) 6285 6720