

MD580-PG-AU1



19012867A00

ABZ & SSI Dual Encoder PG Card User Guide

1

Preface

MD580-PG-AU1 is an ABZ and SSI dual encoder expansion card that supports fully closed-loop control scenarios. The card is connected to the control board by using the FPC cable, and provides the universal DB15 connector which requires a DB15 male connector customized according to the pin sequences defined in the user guide. The ABZ encoder is used to detect the signal input of TTL or RS422 incremental encoders, and the SSI encoder is used to detect the signal input of the absolute encoder adopting the universal serial port protocol. The interface can support power supplies of 5 V, 12 V and 24 V for encoders.

2

Product Information

Terminal arrangement and description

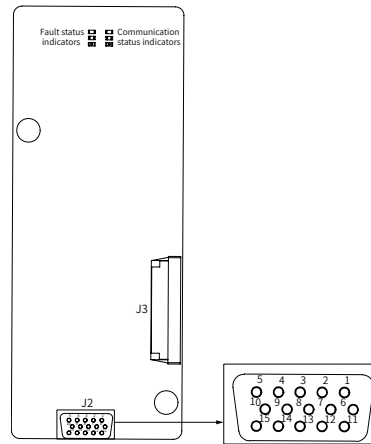

Figure 1 MD580-PG-AU1 terminal arrangement

Type	Pin No.	Pin name	Function	Wiring description	Recommended cable specifications
ABZ & SSI dual-encoder card (J2)	3	Z+	Z signal of the incremental encoder (+)	Twisted pair	Quad-conductor shielded twisted pair cable Cross-sectional area: 0.5mm ² ~2.5 mm ² It is recommended to use a cable with a large cross-sectional area to reduce power consumption and signal loss.
	8	Z-	Z signal of the incremental encoder (-)		
	1	A+	A signal of the incremental encoder (+)	Twisted pair	
	6	A-	A signal of the incremental encoder (-)		
	2	B+	B signal of the incremental encoder (+)	Twisted pair	
	7	B-	B signal of the incremental encoder (-)		
	14	12V	12 V power supply of the encoder	-	
	15	COM	Encoder power supply ground	-	
	4	DATA+	DATA signal of the SSI encoder (+)	Twisted pair	
	9	DATA-	DATA signal of the SSI encoder (-)		
	11	5V	5 V power supply of the encoder	-	
	12	COM	Encoder power supply ground	-	
	13	24V	24 V power supply of the encoder	-	
	5	CLK+	Clock output signal of the SSI encoder (+)	Twisted pair	
	10	CLK-	Clock output signal of the SSI encoder (-)		

3

Communication interface with the control board (J3)	An 18-pin FPC interface to connect to the PG card slot on the control board of the AC drive	-	-
---	---	---	---

Indicator descriptions

Name	Status	Description
Fault status indicator	Red	ABZ encoder fault (disconnection)
	Yellow	SSI encoder fault (frame error or invalid data)
	Green	The ABZ and SSI encoders are normal.
Communication status indicator	Red	SPI communication fault (CRC fault or PG card not activated)
	Green	Communication normal
	Yellow	Reserved

Technical specifications

Item	ABZ	SSI
5 V power supply of the encoder	5 VDC±5%, 500 mA; 12 VDC±10%, 300 mA; 24 VDC±10%, 100 mA	
Encoder input signal	Differential TTL or RS422 incremental signal	RS422 absolute signal
Signal maximum input frequency	500kHz	1 MHz
Disconnection detection	Supported	Supported
Encoder resolution	-	32 bits

Installation and Wiring

Installation instructions

Use M3×8 screws to install MD580-PG-AU1 to the dedicated expansion card slot of the AC drive. The figure below illustrates the installation using the MD580S as an example.

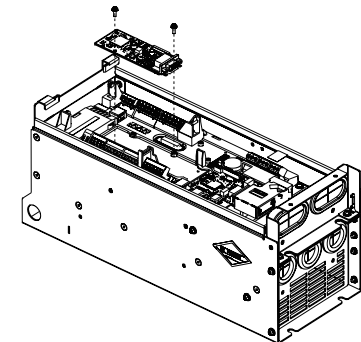

Figure 2 Installation of MD580-PG-AU1

■ Wiring Instructions

Connect the wires as per the diagram below.

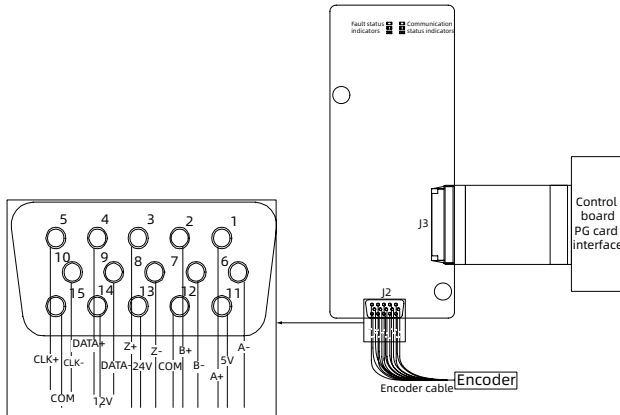

Figure 3 Wiring of MD580-PG-AU1

■ Relationship between the length and the cross-sectional area of the encoder cables

The longer the encoder cable, the greater the cable resistance, and consequently, the larger the voltage drop across the cable resistance for both the encoder power supply and encoder signals. For long-distance applications, improper cable specification will cause the encoder and PG card to malfunction due to signal attenuation induced by cable resistance. Refer to the table below and select appropriate cables based on the on-site cable length. The cable specification is expressed by AWG, which is the US standard measurement for the cross-sectional area of cables.

Table 1 Relationship between the length and the cross-sectional area of the ABZ encoder cable

Cable Length (m)	Specification (AWG)
10	≤ 26
20	
30	≤ 24
40	
50	≤ 22
60	
70	≤ 21
80	
90	≤ 20
100	

Table 2 Relationship between the length and the cross-sectional area of the SSI encoder cable

Cable Length (m)	Specification (AWG)
10	≤ 20
20	
30	
40	
50	≤ 18
80	

Legal and Disclaimers

◆ Copyright Notice

Copyright © Shenzhen Inovance Technology Co., Ltd. 2025 All rights reserved. The copyright of this guide belongs to Shenzhen Inovance Technology Co., Ltd. Without written permission of the company, no unit or individual is allowed to extract, copy, modify, translate, or disseminate the guide in any form.

Legal action will be taken against infringement.

◆ Trademarks

INOVANCE 汇川技术 is a registered trademark of Shenzhen Inovance Technology Co., Ltd. and its affiliates. All other trademarks or registered trademarks mentioned in this documentation are the property of their respective owners. Unauthorized use of these trademarks by third parties for any purpose without written authorization could violate the rights of their owners.

◆ Disclaimer of Liability

Due to continuous updates and improvements of products and technologies, the content of this documentation may not fully match the actual products. In the event of any discrepancies, the actual products shall prevail.

The contents are subject to change without notice due to product upgrade.

◆ Waste Disposal

The storage, use, and disposal of this product (including optional accessories) must comply with local laws and regulations.

◆ Qualified Personnel

The product/system described in this documentation may be operated only by personnel qualified for the specific task in accordance with the relevant documentation, Operations must comply with this guide, especially alarm notices and safety instructions. Qualified personnel can identify the risks of the product/system and prevent possible dangers.

◆ Proper Use of the Product

Proper transportation, storage, assembly, installation, commissioning, operation, and maintenance are required to ensure the safe operation of the product without any problems. The required ambient conditions must be met. All operations must follow the guidelines provided in this documentation.

INOVANCE Warranty Agreement

- Inovance provides an 18-month free warranty (subject to information indicated by the barcode on the equipment) to the equipment itself from the date of manufacturing for the failure or damage under normal use conditions.
- Within the warranty period, maintenance will be charged for the following damage:
 - Equipment damage caused by improper use or unauthorized repair or retrofit
 - Equipment damage caused by fire, flood, abnormal voltage, other disasters and secondary disasters
 - Hardware damage caused by falling or transportation
 - Operations not following the user instructions
 - Damage out of the equipment (for example, external device factors)
- If the equipment is faulty or damaged, fill in the Product Warranty Card correctly.
- Maintenance is charged according to the latest Maintenance Price List of Inovance.
- The Product Warranty Card is not re-issued. Keep the card and present it to the maintenance personnel during maintenance.
- If there is any problem during the service, contact Inovance or Inovance agents.
- This agreement shall be interpreted by Inovance.

INOVANCE Product Warranty Card

Customer Information	Company address:	
	Company name:	Contact:
	Post code:	Tel.:
Product Information	Product model:	
	Product barcode (attached here):	
	Agent name:	
Fault Information	Fault details	
Recorder:		

Suzhou Inovance Technology Co., Ltd.

Add.: No. 52, Tian E Dang Road, Wuzhong District, Suzhou

215104, P.R. China

Tel: (0512) 6637 6666 Fax: (0512) 6285 6720

Website: <http://www.inovance.com>



For more documents:
My Inovance app