



GS20-16EMPL-S Series Digital Input and Output Module User Guide



Industrial
Automation



Intelligent
Elevator



New Energy
Vehicle



Industrial
Robot



Rail
Transit



Data code PS00018166A01

Legal Disclaimer

Copyright Notice

All rights reserved © Shenzhen Inovance Technology Co.,Ltd.

The copyright of this guide belongs to Shenzhen Inovance Technology Co., Ltd. Without written permission of the company, no unit or individual is allowed to extract, copy, modify, translate, or disseminate the guide in any form.

Legal action will be taken against infringement.

Trademark Notice

INOVANCE is the registered trademark of Shenzhen Inovance Technology Co., Ltd. and its affiliates. All other trademarks or registered trademarks mentioned in this guide are the property of their respective owners. The use of these trademarks by third parties for their own purposes without written authorization will infringe upon the rights of their owners.

Disclaimer of Liability

The content of this guide may be not fully match the actual product due to continuous product and technical updates. In case of deviations, the actual product shall prevail.

This guide is subject to change without notice.

Waste Disposal

The storage, use, and disposal of this product (including options) must comply with local laws and regulations.

Personnel Requirements

The product/system described in this guide can only be operated by qualified professionals. Operations must comply with this guide, especially alarm notices and safety instructions. Qualified personnel can identify the risks of the product/system and prevent possible dangers.

Usage Requirements

Proper transportation, storage, assembly, installation, commissioning, operation, and maintenance are prerequisites for the safe and normal operation of the product. It is necessary to use the product in proper environments by following the instructions in this guide.

Preface

Introduction

The GS20-16EMPL-S is an IO-Link slave module with 16 configurable digital channels. Each channel can be configured as either a sink-type input or output. The module can be used with the IO-Link master.

This guide describes the mechanical installation, electrical installation, and program commissioning of the product.

Standards Compliance

The following table lists the certifications, directives, and standards that the product may comply with. For details about the acquired certificates, see the certification marks on the product nameplate.

Certification	Directive		Standard
CE Certification	EMC Directive	2014/30/EU	24 VDC products: EN 61131-2 220 VAC products: EN 61131-2 EN 61000-3-2 EN 61000-3-3
	LVD Directive	2014/35/EU	EN 61010-1 EN 61010-2-201
	RoHS Directive	2011/65/EU amended by (EU)2015/863	EN IEC 63000
UL/cUL Certification	-		UL 61010-1 UL 61010-2-201 CAN/CSA-C22.2 No. 61010-1 CSA C22.2 NO. 61010-2-201
KCC Certification	-		-
EAC Certification	-		-
UKCA Certification	Safety Regulations	Electrical Equipment (Safety) Regulations 2016	EN 61010-1 EN 61010-2-201
	EMC Regulations	Electromagnetic Compatibility Regulations 2016	24 VDC products: EN 61131-2 220 VAC products: EN 61131-2 EN 61000-3-2 EN 61000-3-3
	RoHS Regulations	Directive (RoHS) Regulations 2012	EN IEC 63000

More Data

Name	Code	Description
GS20-EIP-8L High Protection IO-Link Master Module User Guide	PS00018182	Introduces the product information, mechanical installation, electrical installation, programming commissioning, and troubleshooting of the product.
GS20-PN-8L High Protection IO-Link Master Module User Guide	PS00018181	Introduces the product information, mechanical installation, electrical installation, programming commissioning, and troubleshooting of the product.
GS20-ECT-8L High Protection IO-Link Master Module User Guide	PS00007354	Introduces the product information, mechanical installation, electrical installation, programming commissioning, and troubleshooting of the product.
GS20-ECT-8L-INT High Protection IO-Link Master Module User Guide	PS00016635	Introduces the product information, mechanical installation, electrical installation, programming commissioning, and troubleshooting of the product.
GS20-16EMPL-S Digital Input and Output Module User Guide (This guide)	PS00018166	Introduces the mechanical installation, electrical installation, and program commissioning of the product.

Revision History

Date	Version	Revision
July 2025	A01	<ul style="list-style-type: none"> Updated <i>"5.2 Process data"</i> on page 21. Made minor corrections.
January 2025	A00	Initial release.

Access to the Guide

This guide is not delivered with the product. You can obtain the PDF version in the following ways

- Do keyword search under Service and Support at www.inovance.com.
- Scan the QR code on the product with your smart phone.
- Scan the QR code below to install My Inovance app, where you can search for and download user guides.



Warranty Disclaimer

Inovance provides warranty service within the warranty period (as specified in your order) for any fault or damage that is not caused by improper operation of the user. You will be charged for any repair work after the warranty period expires.

Within the warranty period, maintenance fee will be charged for the following damage:

- Damage caused by operations not following the instructions in the user guide
- Damage caused by fire, flood, or unusual voltage
- Damage caused by unintended use of the product
- Damage caused by use beyond the specified scope of application of the product

- Damage or secondary damage caused by force majeure (natural disaster, earthquake, and lightning strike)

The maintenance is charged according to the latest Price List of Inovance. If otherwise agreed upon, the terms and conditions in the agreement shall prevail.

For details, see Product Warranty Card.

Safety Precautions

Safety Disclaimer

1. Read and follow the safety instructions when installing, operating, and maintaining the equipment.
2. To ensure your safety and prevent damage to the equipment, follow the marks on the equipment and all the safety instructions in this guide.
3. "CAUTION", "WARNING", and "DANGER" items in this guide do not indicate all safety precautions that need to be followed; instead, they just supplement the safety precautions.
4. Use this equipment according to the designated environment requirements; otherwise, a fault may occur. Malfunction or damage caused by improper use is not covered by warranty.
5. Inovance shall take no responsibility for any personal injury or property damage caused by improper use.

Safety Levels and Definitions



"DANGER" indicates that failure to comply with the notice will result in death or severe personal injuries.



"WARNING" indicates that failure to comply with the notice may result in death or severe personal injuries.



"CAUTION" indicates that failure to comply with the notice may result in minor or moderate personal injury or equipment damage. Keep this user guide properly for future use and deliver it to the end user.

Control System Design



- Provide a safety circuit outside the PLC so that the control system can still work safely once external power failure or controller fault occurs.
- Add a fuse or circuit breaker because the module may smoke or catch fire due to long-time overcurrent caused by operation above rated current or load short-circuit.



- An emergency stop circuit, a protection circuit, a forward/reverse operation interlocked circuit, and an upper position limit and lower position limit interlocked circuit must be set in the external circuits of PLC to prevent damage to the equipment.
- To ensure safe operation, for the output signals that may cause critical accidents, use external protection circuit and safety mechanism.
- Once the CPU of the controller detects an exception in the system, all outputs may be closed. When a fault occurs in the controller circuit, the output may not be under control. Therefore, it is necessary to set up an external control circuit to ensure normal operation.
- If the output units such as relays or transistors are damaged, the output may fail to switch between ON and OFF states according to the commands.
- The PLC is designed to be used in an indoor electrical environment (overvoltage category II). The power supply must have a system-level surge protector, assuring that overvoltage due to lightning shock cannot be applied to the PLC's power supply input terminals, signal input terminals, and output terminals, to prevent damage to the equipment.

Installation



- Installation must be carried out by skilled personal who have undergone specialized electrical training and possess comprehensive electrical expertise.
- Disconnect all external power supplies of the system before disassembling the module. Failure to do so may result in electric shock, module fault, or malfunction.
- Do not use the PLC in environments with dust, greasy smoke, conductive dust, corrosive or combustible gases, exposed to high temperature, condensation, wind & rain, or subject to vibration and shock. Electric shock, fire, and malfunction may also result in damage or deterioration to the product.
- The PLC is open-type equipment that must be installed in a control cabinet with lock (cabinet housing protection > IP20). Only the skilled personnel who have undergone specialized electrical training and possess comprehensive electrical expertise can open the cabinet.



- Prevent metal filings and wire ends from dropping into ventilation holes of the PLC during installation. Failure to comply may result in fire, fault, and malfunction.
- Ensure there are no foreign matters on ventilation surface. Failure to comply may result in poor ventilation, which may cause fire, fault and malfunction.
- Ensure the module is connected to the respective connector securely and hook the module firmly. Improper installation may result in malfunction, fault or fall-off.
- Ensure natural ventilation for the equipment.

Wiring



- Wiring must be carried out by skilled personnel who have undergone specialized electrical training and possess comprehensive electrical expertise.
- Disconnect all external power supplies of the system before wiring. Failure to comply may result in electric shock, module fault, or malfunction.
- Install the terminal cover attached to the product before power-on or operation after wiring is done. Failure to comply may result in electric shock.
- Insulate the cable terminals properly to ensure the insulation distance between cables will not be shortened after cables are connected to the terminal block. Failure to comply may result in electric shock or damage to the equipment.



- To avoid electric shock, cut off the power supply before connecting the equipment to the power supply.
- The input power supply of this product must be 24 VDC. Power supplies outside $\pm 20\%$ of 24 VDC can cause severe damage to the product. Therefore, check whether the DC power supply provided by the switching-mode power supply is stable at a regular interval.

Operation and maintenance

- Operation and maintenance must be carried out by skilled personnel who have undergone specialized electrical training and possess comprehensive electrical expertise.
- Do not touch the terminals while the power is on. Failure to comply may result in electric shock or malfunction.
- Disconnect all external power supplies of the system before cleaning the module or re-tightening screws on the terminal block or screws of the connector. Failure to comply may result in electric shock.
- Disconnect all external power supplies of the system before assembling/disassembling the module or connecting/removing the communication cables. Failure to comply may result in electric shock or malfunction.

Safety recommendations

- In the position where the operator directly touches the machinery part, for example, where a machinery tool is loaded/unloaded, or where a machine runs automatically, the on-site manual operating devices and any other alternative means must be carefully arranged and designed so that they are independent of the PLC and can start or terminate the automatic running of the system.
- If modification on the program is needed during system operation, use the lock function or other protective measures. Ensure that only authorized personnel can make the necessary modifications.

Disposal

- Treat the scrapped product as industrial waste. Dispose of the battery according to local laws and regulations.
- Recycle retired equipment by observing industry waste disposal standards to avoid environmental pollution.

1 Product Information

1.1 Naming Rules and Nameplate

G S 20 - 16 E M P L - S

① ② ③ ④ ⑤ ⑥ ⑦ ⑧

<p>① Product Family G: Inovance controller general-purpose module</p>	<p>⑤ Module Type E: Logic I/O expansion module</p>
<p>② Product Type S: High protection module</p>	<p>⑥ I/O Type MP: Each channel can be configured as either an PNP input or an PNP output. MN: Each channel can be configured as either an NPN input or an NPN output.</p>
<p>③ Series 20: 20 series</p>	<p>⑦ Connection Type L: IO-Link</p>
<p>④ Number of I/O Channels 16: 16 channels</p>	<p>⑧ Auxiliary Type S: Economical</p>



The data for ordering the product is shown in the following table.

Model	Description	Material Code	Applicable Model
GS20-16EMPL-S	GS20 series transistor PNP module with configurable 16 digital outputs and inputs	01440658	IO-Link master

1.2 Components

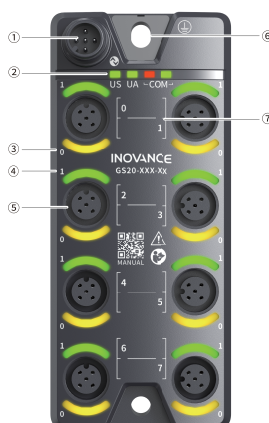

No.	Name	Description	
①	IO-Link port	Used for IO-Link data transmission. For details, see “3.2 Terminal Definition” on page 16	
②	State indicator	US	Power supply indicator <ul style="list-style-type: none"> • Solid green: The voltage is normal. • Single flashing in green: The voltage is abnormal (11 VDC to 18 VDC). • Flashing in green: The voltage is abnormal (> 30.2 VDC). • OFF: The voltage is abnormal (< 11 VDC) and the module cannot operate normally.
		UA	Actuator power supply indicator <ul style="list-style-type: none"> • Solid green: The voltage is normal. • Single flashing in green: The voltage is abnormal (11 VDC to 18 VDC). • Flashing in green: The voltage is abnormal (> 30.2 VDC). • OFF: The voltage is abnormal (< 11 VDC).
		COM	IO-Link communication indicator <ul style="list-style-type: none"> • Steady green: No communication • Slow flashing in green: The IO-Link communication is normal. • Flashing in red: The module reports diagnostic information. • OFF: No voltage present in module
③	Port pin indicator	0	Pin 2 indicator for port 0. The definitions of the lower indicators for port 1 to port 7 are the same as that of pin 2 indicator for port 0. <ul style="list-style-type: none"> • Steady green: The pin input for the corresponding port is valid. • Steady yellow: The pin output for the corresponding port is valid. • Steady red: The pin for the corresponding port encounters a short circuit or an overcurrent. In expert mode, steady red indicates the pin for the corresponding port is configured as an output but an input is detected. • OFF: No input, output, or fault signal Note: Port indicators 0 and 1 both turning red indicates an overcurrent on pin 1 of the corresponding port.
④	Port pin indicator	1	Pin 4 indicator for port 0. The definitions of the upper indicators for port 1 to port 7 are the same as that of pin 4 indicator for port 0. <ul style="list-style-type: none"> • Steady green: The pin input for the corresponding port is valid. • Steady yellow: The pin output for the corresponding port is valid. • Steady red: The pin for the corresponding port encounters a short circuit or an overcurrent. In expert mode, steady red indicates the pin for the corresponding port is configured as an output but an input is detected. • OFF: No input, output, or fault signal Note: Port indicators 0 and 1 both turning red indicates an overcurrent on pin 1 of the corresponding port.
⑤	I/O port	I/O port 2. For details on port pin definitions, see “3.2 Terminal Definition” on page 16	

No.	Name	Description	
⑥	Grounding terminal		During installation, ensure that the protective grounding terminal of the module is grounded properly, with a recommended grounding impedance of less than 1 Ω.
⑦	Port number	0 to 7	There are eight digital I/O ports, each of which contains two configurable DI/DO.

The indicator's quick flashing/single flashing/flashing is defined in the table below.

State	Description
Single flashing	The indicator is on for 200 ms and off for 1000 ms, repeating this cycle.
Flashing	The indicator is on for 200 ms and off for 200 ms, repeating this cycle.
Slow flashing	The indicator is on for 900 ms and off for 100 ms, repeating this cycle.



: High temperature caution for the module.

1.3 Technical Specifications

General specifications

Item	Specification
Dimensions (W x H x D)	50.6 mm x 115.6 mm x 30.5 mm
Weight	About 111 g

Power supply specifications

Item	Specification
Rated voltage of US power supply	24 VDC (18 VDC to 30.2 VDC)
Maximum current of US power supply	2 A (@24 V)
Isolation	Not supported
US reverse polarity protection	Supported
Undervoltage detection	Supported
Rated voltage of UA power supply	24 VDC (18 VDC to 30.2 VDC)
Maximum current of UA power supply	2 A (@24 V)
UA reverse polarity protection	Supported
Undervoltage detection	Supported

Input specifications

Item	Specification
Input type	Digital input
Configuration of inputs	Supported
Input mode	PNP (source mode)

Item	Specification
Maximum number of input channels	16
Input voltage	24 VDC (18 VDC to 30.2 VDC)
Input current (typical value)	4 mA (typical value@0 V)
ON voltage	> 15 VDC
OFF voltage	< 5 VDC
Hardware response time upon ON/OFF	100μs(Max.)/100μs(Max.)
Input impedance	6.6 kΩ to 7.6 kΩ
Isolation	Not supported
Input indicator	The input indicator turns on when the DI circuit is in the active state.
Input derating	Take resistive load as an example, the module operates at full load (with the number of simultaneously ON input channels not exceeding 16) at 60°C, and operates at 50% of full load (with the number of simultaneously ON input channels not exceeding 8) at 70°C.

Output specifications

Item	Specification
Output type	Digital output/transistor output
Configuration of outputs	Supported
Output mode	PNP (source mode)
Maximum number of output channels	16
Output voltage	24 VDC (18 VDC to 30.2 VDC)
Resistive output load	0.5 A/channel; 2 A/module
Inductive output load	7.2 W/channel; 12 W/module
Lamp output load	5 W/channel; 18 W/module
Hardware response time upon ON/OFF	100μs(Max.)/100μs(Max.)
Leakage current upon OFF	10 μA (with 24 VDC)
Isolation	Not supported
Protective functions	Short circuit protection and overcurrent protection
Output indicator	The output indicator turns on when the DO circuit is in the active state.
Output derating	Take resistive load as an example, the module operates at full load (with the output current of all simultaneously ON output channels not exceeding 2 A) at 60°C, and operates at 50% of full load (with the output current not exceeding 1 A) at 70°C.

IO-Link specifications

Item	Specification
IO-Link version	1.1.3
Transmission rate	COM2 (38.4 kbps)
Minimum cycle time	3ms
Minimum cycle time for PDO	3ms
Parameter backup	Supported
Unshielded cable length	Max. 20 m
IO-Link port type	Class A

Software specifications

Item	Specification
State inversion	The 0x40 parameter can be used to invert the input data.
Input/output configuration	The 0x41 parameter can be used to configure the I/O port as input or output.
Fault preset value	The 0x42 and 0x43 parameters can be used to configure the output state when a fault occurs. The function requires support from both master and slave.
Output readback	When the module is used for output, the output state is read back to the master through aperiodic data.
Undervoltage detection	When the voltage of the actuator power supply or system power supply is below 18 V, the status is fed back to the master through aperiodic data.
Module type and basic information reading	When the master communicates with the slave normally, the master can establish communication with the module through configured parameters.
Diagnostic information acquisition (application layer)	Faults, alarms, and maintenance data are obtained through events and are sent from the slave to the master.
Diagnostic information acquisition (link layer)	The diagnostic information is acquired through aperiodic data.
Mode configuration	<p>The 0x49 parameter can be used to configure the module to operate in simple mode or expert mode.</p> <p>Simple mode: Parameter configurations are not required and the parameter configuration function is invalid. All I/O channels can be used as inputs or outputs.</p> <p>Expert mode: All parameters can be configured. By default, 16 inputs are configured. The I/O channels can be quickly configured as 8 inputs and 8 outputs or 16 outputs.</p>

1.4 Environmental Specifications

Item	Operating Specification	Transportation Specification	Storage Specification
IP rating	IP67 (with screws tightened)		
Pollution degree	2		
Immunity	2 kV on power supply line (IEC61000-4-4)		
Overvoltage class	I		
EMC immunity level	Zone B, IEC61131-2		
ESD protection level	Contact discharge +/-6 kV, air discharge +/-8 kV		
Temperature	-30°C to +70°C	-40°C to +85°C	-40°C to +85°C
Humidity	10% RH to 99% RH, without condensation 100% (when all connectors are installed)		

Item		Operating Specification	Transportation Specification	Storage Specification
Vi- bra- tion	Frequency	5 Hz to 500 Hz	2M2	1M12
	Displace- ment	1 mm (direct installation) (5 Hz to 61 Hz)		
	Acceleration rate	15 g (direct installation) (61 Hz to 500 Hz)		
	Direction	X/Y/Z directions		
Shock resistance		Application/Transportation scenario: Tested according to IEC60068-2-27; 15 g peak gravitational acceleration, 11 ms pulse width, total 18 times in X/Y/Z directions		
Altitude/Air pressure		0 m to 2000 m (> 79.5 kPa)	0 m to 2000 m (> 79.5 kPa)	

2 Mechanical Installation

2.1 Installation Dimensions

The installation dimensions (in mm) are shown in the figure below.

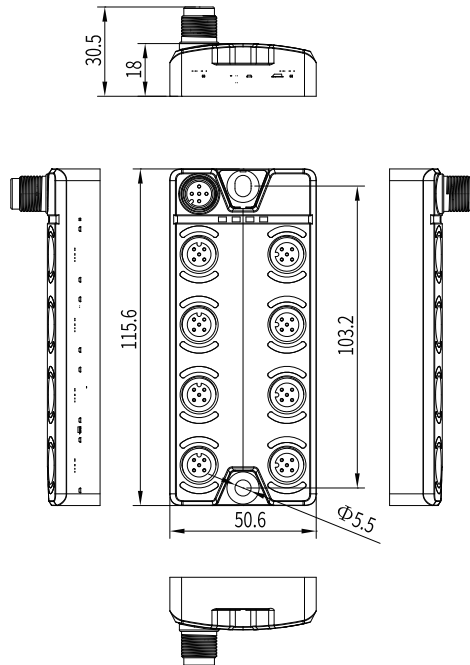

2.2 Installation Method

Installation

Install the module with two cross recessed hexagon SEMS screws (M5 x 25) and 11 mm diameter washers. The clearance between the two screws is 103.2 mm, as shown in the figure below.

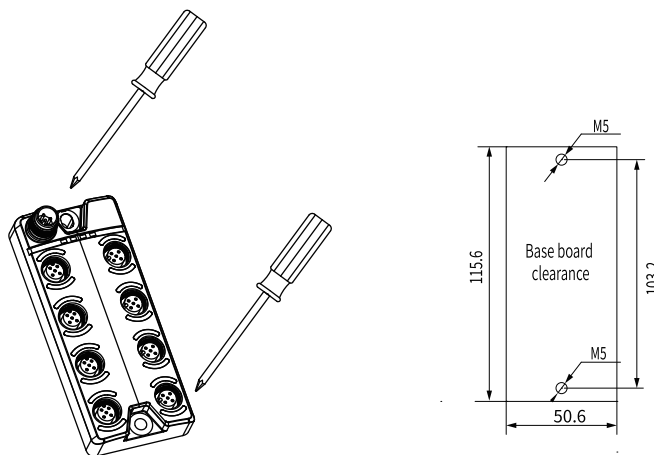

Uninstallation

Remove the M5 screws using a Phillips screwdriver, and then detach the module.

3 Electrical Installation

3.1 Cable Selection

IO-Link communication cable

The data for ordering IO-Link communication cable is as follows:

Model	Description	Length	Material Code
CAB-M12AMS4-M12AFL4-3	Cable assembly - IO-Link cable - Male (straight) - 22AWG - Black - Female (angled) - 85°C (used for connecting the IO-Link master to IO-Link slaves)	3 m	15310142
CAB-M12AMS4-M12AFL4-5		5 m	15310184
CAB-M12AMS4-M12AFL4-8		8 m	15310230
CAB-M12AMS4-M12AFL4-10		10 m	15310183
CAB-M12AMS4-M12AFL4-15		15 m	15310182
CAB-M12AMS4-M12AFL4-3-T-taiyo	Cable assembly - IO-Link cable - Male (straight) - 22AWG - Black - Female (angled) - 85°C - Highly flexible cables fit for drag chains, surviving 3 to 5 million continuous tests (used for connecting the IO-Link master to IO-Link slaves)	3 m	15310232
CAB-M12AMS4-M12AFL4-5-T-taiyo		5 m	15310231
CAB-M12AMS4-M12AFL4-8-T-taiyo		8 m	15310229
CAB-M12AMS4-M12AFL4-10-T-taiyo		10 m	15310228
CAB-M12AMS4-M12AFL4-15-T-taiyo		15 m	15310227

Plug and connector assembly

The data for ordering the plug and connector assembly is as follows:

Model	Description	Material Code
CON-M12AFS4	4-pin female (straight) field-wirable plug	15051155
CON-M12AFL4	4-pin female (angled) field-wirable plug	15051157
CON-M12AMS5	5-pin male (straight) field-wirable plug	15051156
CON-M12AML5	5-pin male (angled) field-wirable plug	15051158
CON-M12AMS5-YF5	Y splitter that converts one 5-pin male M12 connector to two 5-pin female M12 DIO connectors	15051159
CON-M12AMS4-YM8F3	Y splitter that converts one M12 5-pin A-code male straight connector to two M8 3-pin female connectors	15051420
CON-M12AMS4-YM8F4	Y splitter that converts one M12 5-pin A-code male straight connector to two M8 4-pin female connectors	15051419
CON-M8AMS3	M8 3-pin assembled connector	15051445
CON-M8AMS4	M8 4-pin assembled connector	15051448
CON-M12AFS5-YM5	Y splitter that converts one 5-pin female connector to two 5-pin male straight connectors. It can be used to connect the class A master to class B valve terminal slave.	15051334
IPT210-A-CAB-M12AMS5-M12AFS5-1.5	Connector that converts 5-pin male straight connector to 5-pin female straight connector. It can be used to connect the IO-Link master to valve terminal.	72235829
IPT210-A-CAB-M12AFS5-1.5	Connector that converts 5-pin female straight connector to discrete cable. It can be used to power the valve terminal.	72235870

Note

If you have additional requirements for IO-Link cables, contact Inovance for customization.

3.2 Terminal Definition

Assignment of IO-Link pins

The IO-Link interface is an M12A male connector containing the following pins.

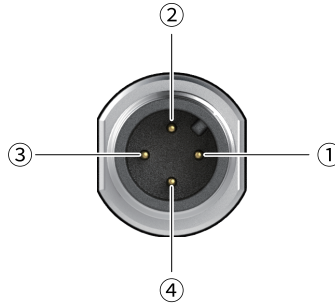

No.	Signal
①	US system and sensor power supply, +24V
②	UA actuator power supply, +24V
③	GND
④	C/Q, IO-Link data transmission

Assignment of port pins

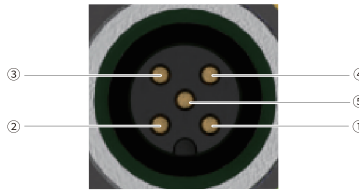

No.	Signal
①	+24V
②	Input 0/Output 0
③	0 V, GND
④	Input 1/Output 1
⑤	Function grounding

3.3 Terminal Wiring

Connecting IO-Link devices

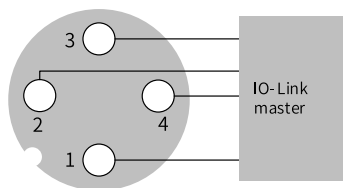

Note

When the DO mode is used, the power supply through Pin 2 must be connected.

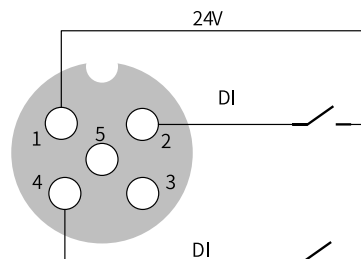
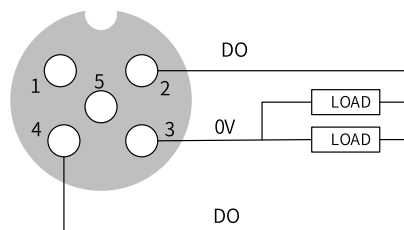
Connecting DI devices**Connecting DO devices**

Note

This module supports the ADP (adaptive DIO) technology developed by Inovance. Based on the type of devices connected:

- When a DI device is connected, the input state can be read by directly assigning a value to the variable "IO_Link_CHN_input byte" in the PLC program.
- When a DO device is connected, the output state can be read by directly assigning a value to the variable "IO_Link_CHN_output byte" in the PLC program.

The ADP technology automatically adapts to the port function, eliminating the need for users to modify hardware configurations or jumpers. Users only need to access the corresponding variables in the program.

4 Program Commissioning

4.1 IO-Link Communication Configuration and Operation

Prerequisites

- Connect the cable properly.
- Install InoProShop V1.7.3 and above.
- Connect to the AC810 PLC properly.
- The PLC is scanned and connected to the I/O-Link master of the GS20-ECT-8L model.

Procedure

1. Double-click **GS20_ECT_8L (GS20-ECT-8L 1.0.5.5)** (①), click **Slots** (②), select the slot to be modified (③), and then click **Delete** (④). Select the module to be configured (⑥) and click **Change** (⑤). Click the compile button (⑦), ensure there are no errors, and then click the download button (⑧). After the download is complete, click the operation button (⑨).

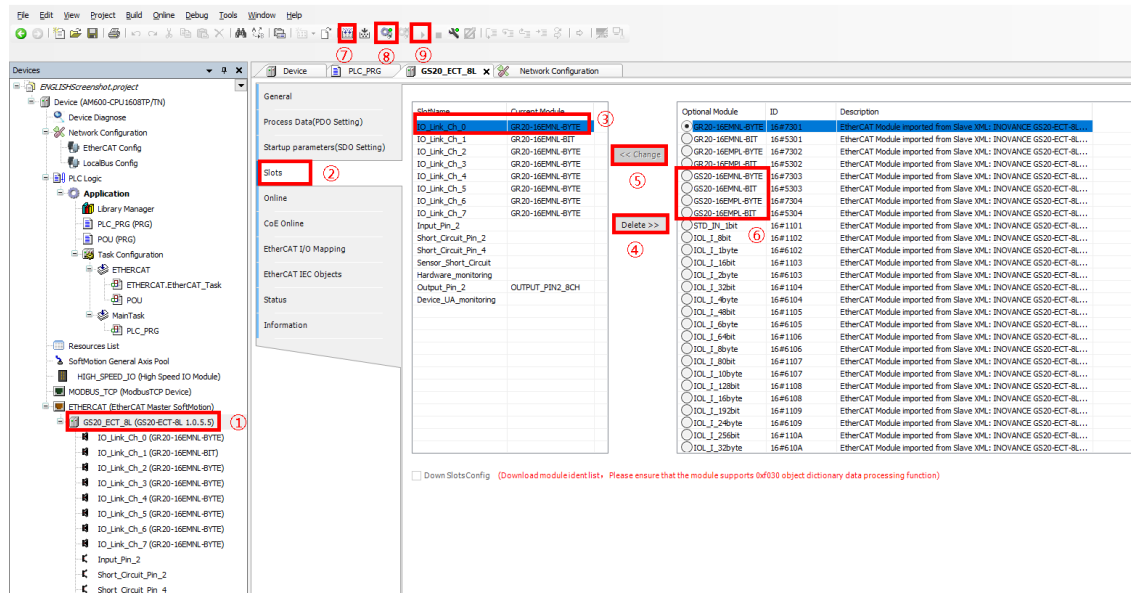

2. Click **EtherCAT I/O Mapping** (⑩) and locate **Status of IO-Link Port 0** (⑪). If the current value is 3, the IO-Link communication is in the OP state. If the slave port is configured as DO, change the **Current Value** cell of **Output_Pin_2 Output Pin 2 of Ch0** (⑫) to **TRUE**.

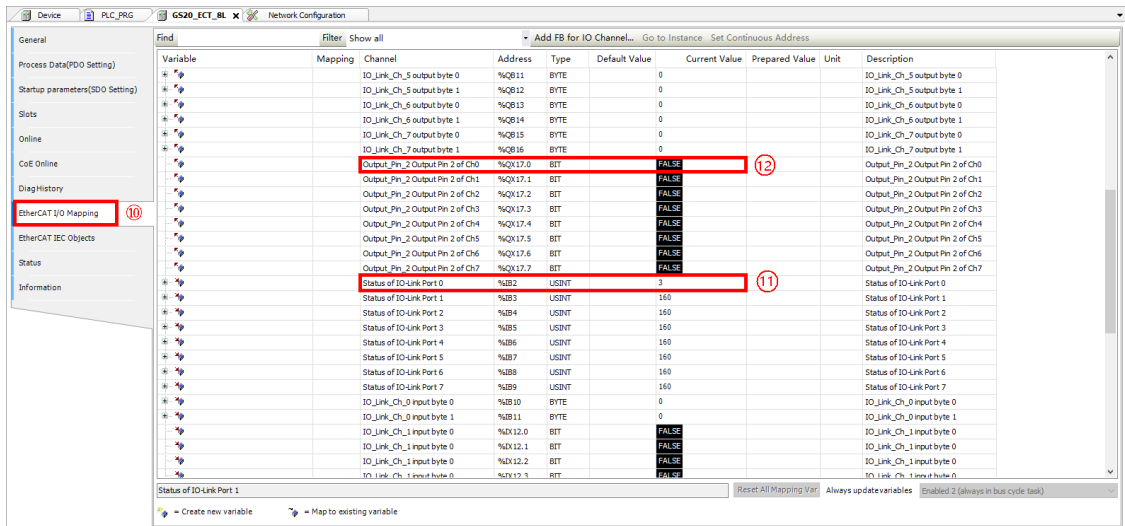

4.2 Port Parameter Configuration

Click **CoE Online** (13). Locate and expand **16#4000 IO-Link service Data Ch. 0** (14).

- Enter the index of the slave to be operated on in the **Value** cell of **Index** (15).
- Enter the subindex of the slave to be operated on in the **Value** cell of **Subindex** (16).
- Enter the length of the data to be operated on in the **Value** cell of **Length** (17).
- Enter the data content to be operated on in the **Value** cell of **Data** (18).
- Enter 0 and then 2 in the **Value** cell of **Control** (19), which indicates that the data at (18) will be written to the slave specified by **Index** (15) and **Subindex** (16). Enter 0 and then 3 in the **Value** cell of **Control** (19), which indicates that the data in the slave specified by **Index** (15) and **Subindex** (16) will be displayed in the **Value** cell of **Data** (18).

Read this page Auto Update Offline from ESI file Online from

Index:Subindex	Name	Flags	Type	Value
16#1C13:16#00	Sync Man 3 Assignment	RW	USINT	
16#1C32:16#00	Sync Man 2 Synchronization	RO	USINT	
16#1C33:16#00	Sync Man 3 Synchronization	RO	USINT	
16#3010:16#00	Port 0 error counter	RO	USINT	
16#3011:16#00	Port 1 error counter	RO	USINT	
16#3012:16#00	ESC error counter	RO	USINT	
16#3016:16#00	Station address	RO	USINT	(14)
16#4000:16#00	IO-Link Service Data Ch. 0			
:16#01	Control	RW	USINT	(19)
:16#02	Status	RO	USINT	
:16#03	Index	RW	UINT	(15)
:16#04	Subindex	RW	USINT	(16)
:16#05	Length	RW	USINT	(17)
:16#06	Data	RW	ARRAY [0..3...	(18)
:16#07	Error Code	RO	UINT	
16#4010:16#00	IO-Link Service Data Ch. 1			
16#4020:16#00	IO-Link Service Data Ch. 2			
16#4030:16#00	IO-Link Service Data Ch. 3			
16#4040:16#00	IO-Link Service Data Ch. 4			
16#4050:16#00	IO-Link Service Data Ch. 5			
16#4060:16#00	IO-Link Service Data Ch. 6			
16#4070:16#00	IO-Link Service Data Ch. 7			
16#8000:16#00	IO-Link Configuration Data Ch. 0	RW	USINT	
16#8010:16#00	IO-Link Configuration Data Ch. 1	RW	USINT	
16#8020:16#00	IO-Link Configuration Data Ch. 2	RW	USINT	
16#8030:16#00	IO-Link Configuration Data Ch. 3	RW	USINT	
16#8040:16#00	IO-Link Configuration Data Ch. 4	RW	USINT	

Note

For details on port parameter configurations, see [“5.3 Product Data” on page 22](#). The 0x49 parameter is used to select a work mode. In the simple mode, parameters are invalid. In the expert mode, parameters can be configured.

5 Object List

5.1 Protocol Stack Data

Baud rate	COM2 (38.4 kBaud)
Minimum cycle time for process data	3ms
IO-Link version	1.1.3
Vendor ID	0x0659
Device ID	-

5.2 Process data

Variable	Physical Pin	Port Indicator		Port Indicator	Physical Pin	Variable
Byte1_0	Pin 4 of port 0	1 (port 0)		1 (port 1)	Pin 4 of port 1	Byte1_1
Byte0_0	Pin 2 of port 0	0 (port 0)		0 (port 1)	Pin 2 of port 1	Byte0_1
Byte1_2	Pin 4 of port 2	1 (port 2)		1 (port 3)	Pin 4 of port 3	Byte1_3
Byte0_2	Pin 2 of port 2	0 (port 2)		0 (port 3)	Pin 2 of port 3	Byte0_3
Byte1_4	Pin 4 of port 4	1 (port 4)		1 (port 5)	Pin 4 of port 5	Byte1_5
Byte0_4	Pin 2 of port 4	0 (port 4)		0 (port 5)	Pin 2 of port 5	Byte0_5
Byte1_6	Pin 4 of port 6	1 (port 6)		1 (port 7)	Pin 4 of port 7	Byte1_7
Byte0_6	Pin 2 of port 6	0 (port 6)		0 (port 7)	Pin 2 of port 7	Byte0_7

Input data	Byte	0							
	Bit	7	6	5	4	3	2	1	0
	Pin	Pin 2 of port 7	Pin 2 of port 6	Pin 2 of port 5	Pin 2 of port 4	Pin 2 of port 3	Pin 2 of port 2	Pin 2 of port 1	Pin 2 of port 0
	Byte	1							
	Bit	7	6	5	4	3	2	1	0
	Pin	Pin 4 of port 7	Pin 4 to port 6	Pin 4 to port 5	Pin 4 to port 4	Pin 4 to port 3	Pin 4 to port 2	Pin 4 to port 1	Pin 4 to port 0
Output data	Byte	0							
	Bit	7	6	5	4	3	2	1	0
	Pin	Pin 2 of port 7	Pin 2 of port 6	Pin 2 of port 5	Pin 2 of port 4	Pin 2 of port 3	Pin 2 of port 2	Pin 2 of port 1	Pin 2 of port 0
	Byte	1							
	Bit	7	6	5	4	3	2	1	0
	Pin	Pin 4 of port 7	Pin 4 to port 6	Pin 4 to port 5	Pin 4 to port 4	Pin 4 to port 3	Pin 4 to port 2	Pin 4 to port 1	Pin 4 to port 0
Input data refers to the data sent from the slave to the master; output data refers to the data sent from the master to the slave.									

5.3 Product Data

Index	Subindex	Object	Length	Range	Default Value
0x07	-	Vendor ID	2 bytes		0x0659
0x08	-	Device ID	2 bytes		0xF42D12
0x10	-	Vendor Name	8 bytes		INOVANCE
0x11	-	Vendor Text	16 bytes		www.inovance.com
0x12	-	Product Name	21 bytes		GS20-16EMPL-S
0x13	-	Product ID	7 bytes		01440658
0x14	-	Product Text	23 bytes		GS20-16Port:IO Sensor/Actuator Hub IP67 16Bit PNP
0x16	-	Hardware Revision	4 bytes		U1 A00
0x17	-	Firmware Revision	4 bytes		2.0.0.0
0x40	0	Inversion	2 bytes		0x0000 to 0xFFFF
0x41	0	Configuration	2 bytes	0x0000 to 0xFFFF	0x0000
0x42	0	Pin 2 Safe State	2 bytes	0x0000 to 0xFFFF	0x0000
0x43	0	Pin 4 Safe State	2 bytes	0x0000 to 0xFFFF	0x0000
0x44	0	Under Voltage	2 bytes	0x0000 to 0xFFFF	0x0000
0x47	0	Feedback	2 bytes	0x0000 to 0xFFFF	0x0000
0x48	0	MCU Temperature Setting	2 bytes	0x0000 to 0xFFFF	0x0050
0x49	0	Mode Configuration	2 bytes	0x0000 to 0xFFFF	0x0000

0x40: Status reverse (R/W)	Byte	0							
	Bit	7	6	5	4	3	2	1	0
	Pin	Pin 2 of port 7	Pin 2 of port 6	Pin 2 of port 5	Pin 2 of port 4	Pin 2 of port 3	Pin 2 of port 2	Pin 2 of port 1	Pin 2 of port 0
	Subindex	8	7	6	5	4	3	2	1
	Default	0	0	0	0	0	0	0	0
	Byte	1							
	Bit	7	6	5	4	3	2	1	0
	Pin	Pin 4 of port 7	Pin 4 to port 6	Pin 4 to port 5	Pin 4 to port 4	Pin 4 to port 3	Pin 4 to port 2	Pin 4 to port 1	Pin 4 to port 0
	Subindex	16	15	14	13	12	11	10	9
	Default	0	0	0	0	0	0	0	0

0 = Disable inversion; 1 = Enable inversion

0x41: Input and output configu- ration (R/ W)	Byte	0							
	Bit	7	6	5	4	3	2	1	0
	Pin	Pin 2 of port 7	Pin 2 of port 6	Pin 2 of port 5	Pin 2 of port 4	Pin 2 of port 3	Pin 2 of port 2	Pin 2 of port 1	Pin 2 of port 0
	Subindex	8	7	6	5	4	3	2	1
	Default	0	0	0	0	0	0	0	0
	Byte	1							
	Bit	7	6	5	4	3	2	1	0
	Pin	Pin 4 of port 7	Pin 4 to port 6	Pin 4 to port 5	Pin 4 to port 4	Pin 4 to port 3	Pin 4 to port 2	Pin 4 to port 1	Pin 4 to port 0
	Subindex	16	15	14	13	12	11	10	9
	Default	0	0	0	0	0	0	0	0
0 = Input; 1 = Output									

Note

When the activator power supply UA is normal and output process data is set, output will be valid.

0x42: Action of pin 2 for port 0 to port 7 (R/ W) when a fault occurs	Byte	1								0							
	Bit	7	6	5	4	3	2	1	0	7	6	5	4	3	2	1	0
	Pin	Pin 2 of port 7		Pin 2 of port 6		Pin 2 of port 5		Pin 2 of port 4		Pin 2 of port 3		Pin 2 of port 2		Pin 2 of port 1		Pin 2 of port 0	
	Subindex	8		7		6		5		4		3		2		1	
	Default	00		00		00		00		00		00		00		00	
	00 = Low level; 01 = High level; 10 = Last state; 11 = Reserved																

Note

The master must support the action to be taken upon a fault. If a preset value is configured, a 0x6320 parameter diagnosis error will be reported.

0x43: Action of pin 4 for port 0 to port 7 (R/W) when a fault occurs	Byte	1								0							
	Bit	7	6	5	4	3	2	1	0	7	6	5	4	3	2	1	0
	Pin	Pin 4 of port 7		Pin 4 to port 6		Pin 4 to port 5		Pin 4 to port 4		Pin 4 to port 3		Pin 4 to port 2		Pin 4 to port 1		Pin 4 to port 0	
	Subindex	8		7		6		5		4		3		2		1	
	Default	00		00		00		00		00		00		00		00	
	00 = Low level; 01 = High level; 10 = Last state; 11 = Reserved																

Note

The master must support the action to be taken upon a fault. If a preset value is configured, a 0x6320 parameter diagnosis error will be reported.

Object List

0x44: System monitoring (R)	Byte	0								1							
	Bit	7	6	5	4	3	2	1	0	7	6	5	4	3	2	1	0
	Pin	-	-	-	-	-	-	-	T	-	-	-	-	UA		US	
	Sub-index	-	-	-	-	-	-	-	1	-	-	-	-	3		2	
	Default	-	-	-	-	-	-	-	0	-	-	-	-	0	0	0	0
	US: System power supply voltage (00 = Normal; 01 = 11 V < voltage < 18 V; 10 = Above 30.2 V; 11 = Below 11 V)																
	UA: Actuator power supply voltage (00 = Normal; 01 = 11 V < voltage < 18 V; 10 = Above 30.2 V; 11 = Below 11 V)																
	T: MCU temperature (0 = MCU temperature below setpoint; 1 = MCU temperature above setpoint)																
-: Not in use																	

0x47: Output state feedback (R)	Byte	0							
	Bit	7	6	5	4	3	2	1	0
	Pin	Pin 2 of DO7	Pin 2 of DO6	Pin 2 of DO5	Pin 2 of DO4	Pin 2 of DO3	Pin 2 of DO2	Pin 2 of DO1	Pin 2 of DO0
	Subindex	8	7	6	5	4	3	2	1
	Default	0	0	0	0	0	0	0	0
	Byte	1							
	Bit	7	6	5	4	3	2	1	0
	Pin	Pin 4 of port 7	Pin 4 to port 6	Pin 4 to port 5	Pin 4 to port 4	Pin 4 to port 3	Pin 4 to port 2	Pin 4 to port 1	Pin 4 to port 0
	Subindex	16	15	14	13	12	11	10	9
	Default	0	0	0	0	0	0	0	0
0 = Output 0; 1 = Output 1									

0x48: MCU temperature setting (R/W)	Byte	0	1
	Default	80	
	-	Unit: °C	

0x49: Mode configuration (R/W)	Value	Mode
	0	Simple mode
	1	Expert mode 1
	3	0808: Configured as eight inputs and eight outputs
	5	0016: Configured as 16 outputs
	8	Expert mode 2
	9	Expert mode 3
	Note: In simple mode and expert mode 2, parameters 0x41 to 0x43 are unavailable. If the configuration are not set as mentioned above, a 0x6320 fault is reported, requiring you to revert to the last valid configuration.	

6 Troubleshooting

Common faults

Fault 1: When the GS20-ECT-8L master connects to an IO-Link slave, the UA and US indicators of the master are solid on, but the UA, US, and COM indicators of the slave are off.

Analysis:

- Cause: The GS20-ECT-8L module is not in safe-operational (SAFEOP) or operational (OP) state.
- Description: The GS20-ECT-8L module needs to enter SAFEOP or OP state to power the slave. Otherwise, the module cannot supply power normally.

Solution:

After downloading the PLC program, ensure that the GS20-ECT-8L module is in OP state (with the RUN indicator solid on). If the module is not running, refer to the "EtherCAT Diagnosis" section in *GS20-ECT-8L High Protection IO-Link Master Module User Guide*.

Fault 2: When the GS20-ECT-8L master connects to a GS20/GR20 slave, the UA, US, and RUN indicators of the master are solid on, while the US indicator of the slave is solid on, the UA indicator is off, and the COM indicator is flashing in red.

Analysis:

- Cause: The Pin 2 of the port corresponding to the IO-Link master is not enabled.
- Description: When the IO-Link master connects to the GS20/GR20 slave, it is necessary to set the Pin 2 of the corresponding master port to high level in the PLC program to provide I/O side power to the slave.

Solution:

1. Log in to the PLC device and open the configuration interface of the master. Click "EtherCAT I/O Mapping" to enable the Pin 2 of the corresponding master port (by setting the "Output_Pin_2 Output Pin 2 of Chn" variable to TRUE).

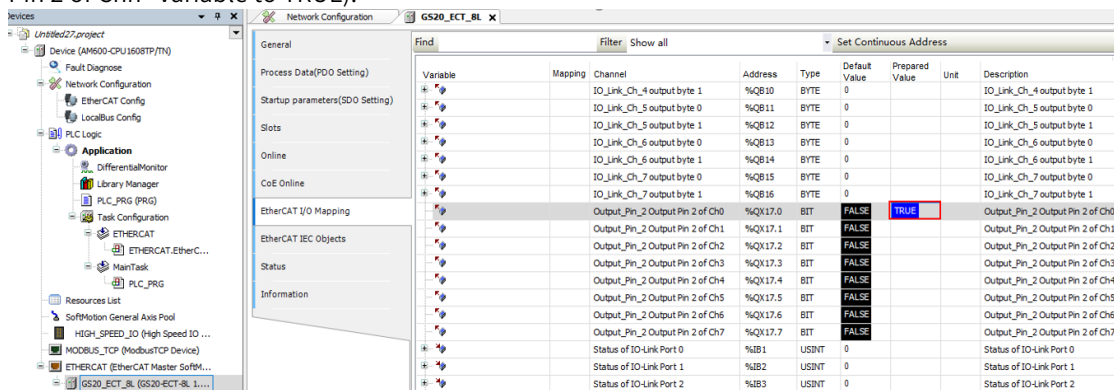

2. Observe the state of master/slave:

- Master: The UA indicator is solid on.
- Slave: The US and UA indicators are solid on, and the COM indicator is flashing in green.
- If the indicators are as above, it indicates that communication has been successfully established and is available for normal use.

- If the indicators are not as above, check whether the IO-Link communication cable connection between the master and slave is secure and undamaged; check whether the power cable of the master is damaged.

Note

- For Pin2 output, see "Module Configuration Function" of the GS20-PN-8L Series High Protection IO-Link Master Module User Guide.
- For Pin2 output, see "Data Configuration" of the GS20-EIP-8L Series High Protection IO-Link Master Module User Guide.
- For Pin2 output, see "GS20-16EMNL Slave Configuration" of the GS20-ECT-8L Series High Protection IO-Link Master Module User Guide.

Issue Code

The issue codes of the slave are reported to the master, where you can view the issue information, as shown below.

Code	Type	Description	Solution
0x4210	Alarm	Overtemperature	The ambient temperature is too high. Decrease the temperature before using the module.
0x4220	Alarm	Undertemperature	The ambient environment is too low. Increase the temperature before using the module.
0x5011	Fault	Loss of retentive data upon power failure	Retention of configuration parameters fails. Re-configure the parameters.
0x5100	Fault	Device power supply fault	The UA power supply of the module fails. Enable the power supply to Pin2 on the master or use the external UA power supply.
0x5110	Alarm	System power supply overvoltage	The US power supply voltage of the module is higher than the normal operating voltage. Decrease the US power supply voltage. Note: This alarm is reported in the log and only occurs in medium-sized PLCs.
0x5111	Alarm	System power supply undervoltage	The US power supply voltage of the module is lower than the normal operating voltage. Increase the US power supply voltage.
0x7710	Fault	Short circuit	The module encounters a short circuit. Check the external wiring.
0x6320	Fault	Parameter fault	The module parameters are configured incorrectly. Configure the parameters correctly according to the product data.
0x6321	Fault	Parameter loss	In expert mode, an input signal is detected for a channel configured as output. Modify the input/output configuration parameter 0x41 according to actual usage.

7 Appendix: Version Matching Information

You can get the module firmware from Inovance technical support engineers. The InoProShop software can be downloaded from the software and commissioning tool interface of any medium-sized PLC series at <https://www.inovance.com>. The following table describes the version matching information.

Module Firmware Version	InoProShop version
2.0.0.0 and later	V1.7.3 SP2 and later

Service and Support

Should you encounter a safety accident during the use or operation of the product, or face challenges in operating and maintaining the equipment, which remain unresolved after the relevant documentation is consulted, we provide multiple channels to ensure prompt resolution:

- Channel #1: Contact service@inovance.com.
- Channel #2: Visit <https://www.inovance.com/global> to access document downloads, after-sales support, spare parts ordering, repair applications, and authenticity verification services.
- Channel #3: Download My Inovance app (<https://zshc-eu.inovance.com/download-pc/>) where you can access products info and documentation, and query product parameters.

We are committed to providing you with quick and professional technical support, and we look forward to your satisfaction and trust.



Copyright © Shenzhen Inovance Technology Co., Ltd.

PS00018166A01

Shenzhen Inovance Technology Co., Ltd.

www.inovance.com

Suzhou Inovance Technology Co., Ltd.

www.inovance.com

Add.: Inovance Headquarters Tower, High-tech Industrial Park,
Guanlan Street, Longhua New District,
Shenzhen 518000, P.R. China

Tel: (0755) 2979 9595

Fax: (0755) 2961 9897

Add.: No. 52, Tian E Dang Road, Wuzhong District, 215104,
Suzhou City, Jiangsu Province, P.R. China

Tel: (0512) 6637 6666

Fax: (0512) 6285 6720