



GL20-4TC-ISO Series Isolated Thermocouple Temperature Detection Module User Guide



Industrial
Automation



Intelligent
Elevator



New Energy
Vehicle



Industrial
Robot



Rail
Transit



Data code PS00021374A00

Legal Information

Copyright

Copyright © Shenzhen Inovance Technology Co., Ltd. 2024 All rights reserved

This documentation is the exclusive property of Shenzhen Inovance Technology Co., Ltd. No individual or entity may excerpt, reproduce, modify, translate, or distribute any content herein without written consent from Inovance.

Legal action will be taken against infringement.

Trademarks

INOVANCE is a registered trademark of Shenzhen Inovance Technology Co., Ltd. and its affiliates. All other trademarks or registered trademarks mentioned in this documentation are the property of their respective owners. Unauthorized use of these trademarks by third parties for any purpose without written authorization could violate the rights of their owners.

Disclaimer of Liability

Due to continuous updates and improvements of products and technologies, the content of this documentation may not fully match the actual products. In the event of any discrepancies, the actual products shall prevail.

The contents are subject to change without notice due to product upgrade.

Waste Disposal

The storage, use, and disposal of this product (including optional accessories) must comply with local laws and regulations.

Qualified Personnel

The product/system described in this documentation may be operated only by personnel qualified for the specific task in accordance with the relevant documentation, in particular its warning notices and safety instructions. Qualified personnel can identify the risks of the product/system and prevent possible dangers.

Proper Use of the Product

Proper transportation, storage, assembly, installation, commissioning, operation, and maintenance are required to ensure the safe operation of the product without any problems. The required ambient conditions must be met. All operations must follow the guidelines provided in this documentation.

Preface

Introduction

The GL20-4TC-ISO is a 4-channel isolated thermocouple temperature detection module. It can be used with GL20-RTU-ECT32 series communication interface modules.

This guide describes the mechanical installation, electrical installation, program commissioning, troubleshooting, and version matching information of the product.

Standards Compliance

The following table lists the certifications, directives, and standards that the product may comply with. For details about the acquired certificates, see the certification marks on the product nameplate.

Certification	Directive		Standard
CE Certification	EMC Directive	2014/30/EU	24 VDC products: EN 61131-2 220 VAC products: EN 61131-2 EN 61000-3-2 EN 61000-3-3
	LVD Directive	2014/35/EU	EN 61010-1 EN 61010-2-201
	RoHS Directive	2011/65/EU amended by (EU)2015/863	EN IEC 63000
UL/cUL Certification	-		UL 61010-1 UL 61010-2-201 CAN/CSA-C22.2 No. 61010-1 CSA C22.2 NO. 61010-2-201
KCC Certification	-		-
EAC Certification	-		-
UKCA Certification	Safety Regulations	Electrical Equipment (Safety) Regulations 2016	EN 61010-1 EN 61010-2-201
	EMC Regulations	Electromagnetic Compatibility Regulations 2016	24 VDC products: EN 61131-2 220 VAC products: EN 61131-2 EN 61000-3-2 EN 61000-3-3
	RoHS Regulations	Directive (RoHS) Regulations 2012	EN IEC 63000

More Data

Name	Code	Description
GL20-RTU-ECT/ECT32 Series Communication Interface Module User Guide	19012622	Introduces the information, mechanical installation, electrical installation, program commissioning, and troubleshooting of the product.
GL20-4TC-ISO Series Temperature Detection Module User Guide (This guide)	PS00021374	Introduces the mechanical installation, electrical installation, program commissioning, troubleshooting, and version matching information of the product.

Revision History

Date	Version	Revision
July 2025	A00	Initial release.

Access to the Guide

This guide is not delivered with the product. You can obtain the PDF version in the following ways

- Do keyword search under Service and Support at www.inovance.com.
- Scan the QR code on the product with your smart phone.
- My Inovance APP: Scan the QR code below to install the app, where you can search for and download user guides.



Warranty Disclaimer

Inovance provides warranty service within the warranty period (as specified in your order) for any fault or damage that is not caused by improper operation of the user. You will be charged for any repair work after the warranty period expires.

Within the warranty period, maintenance fee will be charged for the following damage:

- Damage caused by operations not following the instructions in the user guide
- Damage caused by fire, flood, or unusual voltage
- Damage caused by unintended use of the product
- Damage caused by use beyond the specified scope of application of the product
- Damage or secondary damage caused by force majeure (natural disaster, earthquake, and lightning strike)

The maintenance is charged according to the latest Price List of Inovance. If otherwise agreed upon, the terms and conditions in the agreement shall prevail.

For details, see Product Warranty Card.

Fundamental Safety Instructions

Safety Precautions

1. Read and follow the safety instructions when installing, operating, and maintaining the equipment.
2. To ensure your safety and prevent damage to the equipment, follow the marks on the equipment and all the safety instructions in this guide.
3. "CAUTION", "WARNING", and "DANGER" items in this guide do not indicate all safety precautions that need to be followed; instead, they just supplement the safety precautions.
4. Use this equipment according to the designated environment requirements; otherwise, a fault may occur. Malfunction or damage caused by improper use is not covered by warranty.
5. Inovance shall take no responsibility for any personal injury or property damage caused by improper use.

Safety Levels and Definitions





"DANGER" indicates that failure to comply with the notice will result in death or severe personal injuries.



"WARNING" indicates that failure to comply with the notice may result in death or severe personal injuries.



"CAUTION" indicates that failure to comply with the notice may result in minor personal injuries or equipment damage. Keep this user guide properly for future use and deliver it to the end user.

Control System Design	
	<ul style="list-style-type: none">• Provide a safety circuit outside the PLC so that the control system can still work safely once external power failure or controller fault occurs.• Add an external fuse or circuit breaker to prevent the module from smoking or catching fire due to long-time overcurrent caused by operation above rated current or load short-circuit.
	<ul style="list-style-type: none">• An emergency stop circuit, a protection circuit, a forward/reverse operation interlocked circuit, and an upper position limit and lower position limit interlocked circuit must be set in the external circuits of PLC to prevent damage to the equipment.• To ensure safe operation, for the output signals that may cause critical accidents, use external protection circuit and safety mechanism.• Once the CPU of the PLC detects an exception in the system, all outputs may be closed; however, when a fault occurs in the controller circuit, the output may not be under control. Therefore, it is necessary to design an appropriate external control circuit to ensure normal operation.• If the output units such as relays or transistors are damaged, the output may fail to switch between ON and OFF states according to the commands.• The PLC is designed to be used in an indoor electrical environment compliant with overvoltage category II. The power supply must have a system-level surge protector to ensure that overvoltage caused by lightning shock cannot be applied to power supply input terminals, signal input terminals, and control output terminals of the PLC, therefore preventing damage to the product.

Installation

- Installation must be carried out by skilled personal who have undergone specialized electrical training and possess comprehensive electrical expertise.
- Disconnect all external power supplies of the system before installing/removing the module. Failure to do so may result in electric shock, module fault, or malfunction.
- Do not use the PLC in environments with dust, greasy smoke, conductive dust, corrosive or combustible gases, exposed to high temperature, condensation, wind & rain, or subject to vibration and shock. Electric shock, fire, and malfunction may also result in damage or deterioration to the product.
- The PLC is open-type equipment that must be installed in a control cabinet with lock (cabinet housing protection > IP20). Only the skilled personnel who have undergone specialized electrical training and possess comprehensive electrical expertise can open the cabinet.



- Prevent metal filings and wire ends from dropping into ventilation holes of the PLC during installation. Failure to comply may result in fire, fault, and malfunction.
- Ensure there are no unwanted matters on ventilation surface. Failure to comply may result in poor ventilation, which may cause fire, fault, or malfunction.
- Ensure the module is connected to the respective connector securely and hook the module firmly. Improper installation may result in malfunction, fault, or fall-off.
- Ensure natural ventilation for the equipment.

Wiring

- Wiring must be carried out by skilled personnel who have undergone specialized electrical training and possess comprehensive electrical expertise.
- Disconnect all external power supplies of the system before wiring. Failure to comply may result in electric shock, module fault, or malfunction.
- After wiring, install the terminal cover attached to the product before power-on or operation. Failure to comply may result in electric shock.
- Insulate the cable terminals properly to ensure the insulation distance between cables will not be shortened after cables are connected to the terminal block. Failure to comply may result in electric shock or damage to the product.



- To avoid electric shock, cut off the power supply before connecting the equipment to the power supply.
- The input power supply of this product must be 24 VDC. Power supplies outside $\pm 20\%$ of 24 VDC can cause severe damage to the product. Therefore, check whether the DC power supply provided by the switching-mode power supply is stable at a regular interval.

Operation and maintenance



- Operation and maintenance must be carried out by skilled personnel who have undergone specialized electrical training and possess comprehensive electrical expertise.
- Do not touch the terminals while the power is on. Failure to comply may result in electric shock or malfunction.
- Disconnect all external power supplies of the system before cleaning the module or re-tightening screws on the terminal block or the connector. Failure to comply may result in electric shock.
- Disconnect all external power supplies of the system before assembling/disassembling the module or connecting/removing the communication cables. Failure to comply may result in electric shock or malfunction.

Safety Recommendations

- In the position where the operator directly touches the machinery part, for example, where a machinery tool is loaded/unloaded, or where a machine runs automatically, the on-site manual operating devices and any other alternative means must be carefully arranged and designed so that they are independent of the PLC and can start or terminate the automatic running of the system.
- If modification on the program is needed during system operation, use the lock function or other protective measures. Ensure that only authorized personnel can make the necessary modifications.

Disposal



- Treat the scrapped product as industrial waste. Dispose of the battery according to local laws and regulations.
- Recycle retired equipment by observing industry waste disposal standards to avoid environmental pollution.

1 Product Information

1.1 Introduction

Basic information

Model	Description	Material Code	Applicable Model
GL20-4TC-ISO	GL20 series 4-channel isolated thermocouple temperature detection module	01440908	Applicable to the GL20-RTU-ECT32 series communication interface module

The GL20-4TC-ISO module offers the following advantages over the GL20-4TC module:

- Supports isolation among channels, eliminating crosstalk.
- Supports internal and external cold junction configuration, making it suitable for high-precision temperature measurement scenarios.
- Requires no connection to an external 24 V power supply

Main features

Item	Specification
Rated current of bus input power supply	165 mA (typical@ 5 V)
Number of input channels	4
Input terminal	<ul style="list-style-type: none"> • Thermocouple input • Microvoltage input: ± 100 mV
Input type	Supports the following input types: <ul style="list-style-type: none"> • Thermocouple types: B, E, N, J, K, R, S, T • Microvoltage measurement: ± 100 mV
Compensation method	Internal/external cold junction compensation <ul style="list-style-type: none"> • Supports internal cold junction compensation with a sampling error of $\pm 2^{\circ}\text{C}$. • Supports external PT100 cold junction compensation with two-wire mode, three-wire mode (default), and four-wire mode.
Isolation method	Supports isolation between I/O terminals and the system, as well as isolation among I/O channels.

Spare parts

Name	Description	Code
Terminal block (marked as AB)	Pluggable terminal block with spring clamp wiring	15212511

1.2 Model and Nameplate

GL 20 -4 TC- ISO

- ① ② ③ ④ ⑤

①	Product Information GL: Inovance general local module	④	Module Type TC: Thermocouple temperature detection
②	Series Number 20: 20 series module	⑤	Auxiliary Type ISO: Isolated
③	Number of Input Channels 4: 4 input channels	-	



INOVANCE

GL20-4TC-ISO
4- channels input thermocouple
temperature detection isolated module
POWER INPUT: NONE
OUTPUT: NONE
SN:0123456789123456

QC PASSED

Four-wire mode

PT

	A	B
← L0+	1	L0-
← NC	2	NC
← L1+	3	L1-
← RTD+	4	RTD-
← I+	5	I-
← L2+	6	L2-
← NC	7	NC
← L3+	8	L3-
← •	9	PE





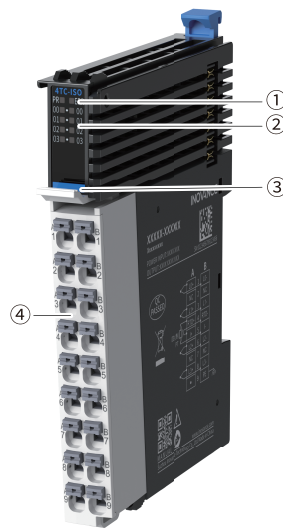

MANUAL

Suzhou Inovance Technology Co., Ltd. Made in China

www.inovance.com

1.3 Components



No.	Component	Description			
①	Signal indicators	PR (POWER+RUN)	Power/Run indicator	Yellow-green	<ul style="list-style-type: none"> • Solid ON: The module is operating normally. • Flashing quickly: The module is addressed successfully. • Flashing slowly: The module is powered on but not addressed. • OFF: The module is not powered on or is faulty.
		ERR	Fault indicator	Red	<ul style="list-style-type: none"> • ON when the module is faulty. For details, see “Troubleshooting” on page 28
②	Channel operation indicator	00 to 03	Channel operation indicator	Yellow-green	<ul style="list-style-type: none"> • Solid ON: The channel is running normally. • OFF: The channel is closed or faulty.
	Communication fault indicator	00 to 03	Channel fault indicator	Red	<ul style="list-style-type: none"> • Solid ON: The channel is faulty. • OFF: The channel is normal.
③	I/O terminals	Four thermocouple inputs, as defined in “ 3.2 Terminal Definition ” on page 16			
④	Color identification		Red: Digital output		Orange: Analog output
			Gray: Digital input		Green: Analog input
			White: Communication		Blue: Other modules

Note

- Flashing quickly: The indicator is ON for 200ms and OFF for 200ms.
- Flashing slowly: The indicator is ON for 200ms and OFF for 1s.

1.4 Technical Specifications

General specifications

Item	Specification
IP rating	IP20
Dimensions (W x H x D)	12 mm x 100 mm x 75 mm
Weight	About 61 g

Power supply specifications

Item	Specification
Rated voltage of bus input power supply	5 VDC (4.75 VDC to 5.25 VDC)
Rated current of bus input power supply	165 mA (typical value@5 V)
Rated voltage of terminal output power supply	/
Rated current of terminal output power supply	/
Hot swap	Not supported
Anti-reverse connection for 24 V input	Not supported

Input specifications

Item	Specification
Number of input channels	4
Input terminal	<ul style="list-style-type: none"> • Thermocouple input • Microvoltage input: ± 100 mV
Input type	Supports the following input types: <ul style="list-style-type: none"> • Thermocouple types: B, E, N, J, K, R, S, T • Microvoltage measurement: ± 100 mV
Compensation method	Internal/external cold junction compensation <ul style="list-style-type: none"> • Supports internal cold junction compensation with a sampling error of $\pm 2^\circ\text{C}$. • Supports external PT100 cold junction compensation with two-wire mode, three-wire mode (default), and four-wire mode.
Digital resolution	24-bit resolution
Display sensitivity	0.1, 0.01, and 0.001 (configurable through software)
Accuracy (at normal temperature: 25°C)	<ul style="list-style-type: none"> • Thermocouple accuracy: $(\pm 0.1\%)^{[1]}$(full scale ± 100 mV) + cold junction compensation error^[2] • Microvoltage accuracy: $\pm 0.1\%$@ (full scale ± 100 mV)
Accuracy (at operating temperature: -20°C to $+55^\circ\text{C}$)	<ul style="list-style-type: none"> • Thermocouple accuracy: $(\pm 0.3\%)^{[1]}$(full scale ± 100 mV) + cold junction compensation error^[2] • Microvoltage accuracy: $\pm 0.3\%$@ (full scale ± 100 mV)
Interchannel consistency (at normal temperature: 25°C)	<ul style="list-style-type: none"> • Thermocouple accuracy: $(\pm 0.1\%)^{[1]}$(full scale ± 100 mV) + cold junction compensation error^[2] • Microvoltage accuracy: $\pm 0.1\%$@ (full scale ± 100 mV)
Interchannel consistency (at ambient temperature: -20°C to $+55^\circ\text{C}$)	<ul style="list-style-type: none"> • Thermocouple accuracy: $(\pm 0.3\%)^{[1]}$(full scale ± 100 mV) + cold junction compensation error^[2] • Microvoltage accuracy: $\pm 0.3\%$@ (full scale ± 100 mV)

Item	Specification
Interference suppression among channels	/
Isolation method	Supports isolation between I/O terminals and the system, as well as isolation among I/O channels.
Voltage resistance of isolation	With a 500 VAC voltage applied among isolated channels for 1 minute, the leakage current is less than 5 mA.
Input indicator	/
Input derating	/
Overflow and open circuit detection	Supported

Note

- ^[1]: Indicates ADC sampling accuracy, which needs to be determined based on sensor type and thermocouple detection temperature range. For details, see [“6.1 Appendix 1: Accuracy Calculation” on page 30](#).
- ^[2]: The cold junction compensation error needs to be determined based on the mounting direction, adjacent module type and operating temperature range. For details, see [“6.1 Appendix 1: Accuracy Calculation” on page 30](#).

Software specifications

Item	Specification
Input PDO data volume	Max. 16 bytes
Diagnostic report configuration	Supported
Diagnostic detection enable configuration	Overflow and offline detection supported
Sampling Cycle	Single channel: 20ms/Chn, 40ms/Chn, 100ms/Chn Full channel: 250ms/4Chn, 500ms/4Chn, 1000ms/4Chn
Filter time	The moving average filter time can be configured as a multiple of the sampling cycle. Options include: None, 2T, 4T, 8T (default), 16T, 32T, 64T.
Display mode	Centigrade degree (°C), Fahrenheit degree (°F), and Kelvin (K)
Overflow and underflow detection	Overflow and underflow faults are reported only when the overflow detection function is enabled.
Overflow detection configuration	Supported
Independent channel configuration	Supported
Temperature offset configuration	Supported
Power frequency suppression	When the power frequency suppression is enabled, the power frequency interference is significantly reduced, improving the signal-to-noise ratio.
Sampling refresh	Refresh asynchronously according to the sampling cycle, with no need to refresh synchronously according to the bus cycle
Stop mode	Output based on the maximum value with no further refresh
Open circuit or overflow/underflow detection	Output based on the maximum value with no further refresh
System diagnosis	System power supply fault
Channel diagnosis	Upper limit exceeded alarm, lower limit exceeded alarm, open circuit alarm, and overflow/underflow alarm

1.5 Environmental Specifications

Item	Specification
Installation/Operating environment	Free from conductive dust, conductive fibers, explosive dust, flammable gases, water mist/greasy dirt, corrosive dusts/gases, strong vibration, and repetitive shock
Max. altitude	≤ 2000 m
Pollution degree	2
Immunity	2 kV on power supply cable (compliant with IEC 61000-4-4)
Overvoltage category	I
EMC immunity level	Zone B, IEC61131-2
ESD protection level	Contact discharge +/-6 kV, air discharge +/-8 kV
Vibration resistance	<ul style="list-style-type: none"> • Application scenario: Tested according to IEC60068-2-6; 3.5 mm amplitude at 5 Hz to 8.4 Hz; 1 g acceleration at 8.4 Hz to 200 Hz; in ten cycles/axes • Transportation scenario: Tested according to IEC60068-2-64; 0.01 g²/Hz power spectral density at 5 Hz to 100 Hz; 0.001 g²/Hz power spectral density at 200 Hz; Grms: 1.14 g
Shock resistance	Application/Transportation scenario: Tested according to IEC60068-2-27; 15 g peak gravitational acceleration; 11ms pulse width; 18 times in X/Y/Z-axis directions
Operating temperature/humidity	<ul style="list-style-type: none"> • Temperature: -20°C to +55°C • Humidity: < 95% RH (30°C), without condensation
Storage temperature/humidity	<ul style="list-style-type: none"> • Temperature: -20°C to +60°C • Humidity: < 95% RH (30°C), without condensation
Transportation temperature/humidity	<ul style="list-style-type: none"> • Temperature: -40°C to +70°C • Humidity: < 95% RH (40°C), without condensation

2 Mechanical Installation

2.1 Installation Precautions

- Make sure the module is powered off before installing or removing.
- Do not hot swap the modules. Otherwise, the modules may be damaged by overcurrent or overvoltage, and the communication interface module or PLC may be subject to restart, user data loss or corruption.
- Do not drop or shock the housing or terminals of the module to avoid damage.

2.2 Installation Dimensions

Module

The installation dimensions (in mm) are shown in the figure below.

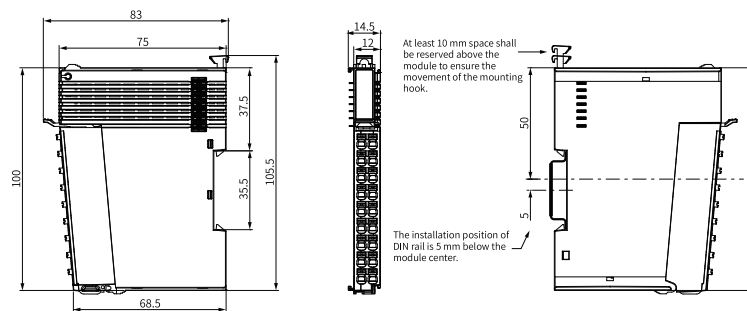

Cable connection

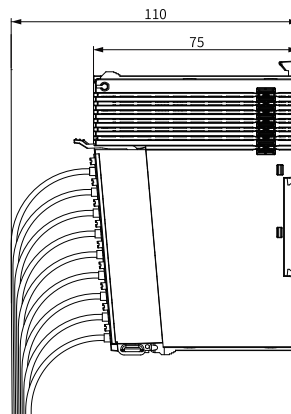

2.3 Installation Method

The module is mounted onto a DIN rail in conformity with IEC 60715 (width: 35 mm, thickness: 1 mm). The dimensions (unit: mm) are shown below.

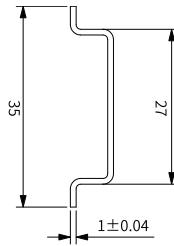

When installed on a DIN rail other than the recommended one (especially the one whose thickness is not 1.0 mm), the product will not fit in place as the mounting hook does not work.

Installing modules side by side

Install modules side by side by sliding them along the top and bottom guide rails of adjacent modules.

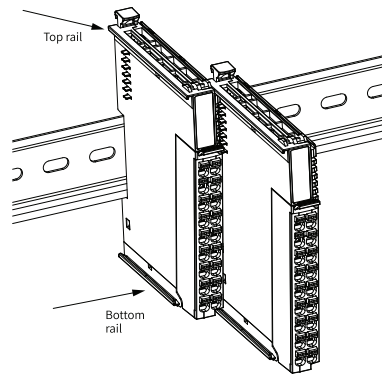

Installing modules onto DIN Rail

1. Align the module with the DIN rail and push the module in the direction indicated by the arrow until you hear a click, as shown below.

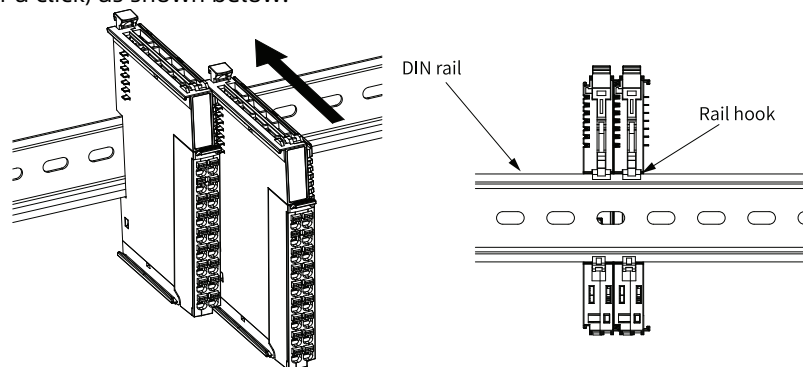

2. Make sure the DIN rail mounting hook of the module is locked. The locked and unlocked states of the mounting hook are shown below.

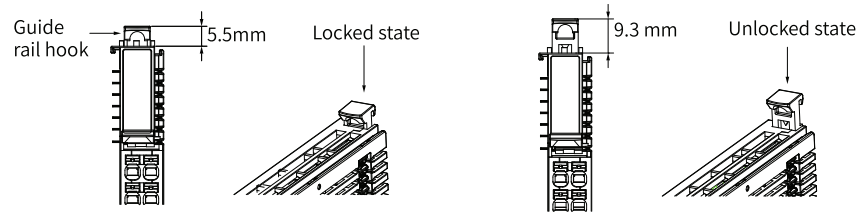

- If the mounting hook is pressed down, it is locked.
- If the mounting hook is lifted up, it is unlocked.

To lock the module to the DIN rail, press down the mounting hook.



Caution

When the module is not installed on the DIN rail, keep the rail hook in locked state. A hook that kept in unlocked state for a long period of time may fail to function properly.

3. Install a DIN rail end plate on both sides of the PLC or the module.

To install the end plate, hook the bottom of it to the bottom of the DIN rail, rotate the end plate to hook the top of it to the top of the DIN rail, and then tighten the screw to lock the end plate in place,

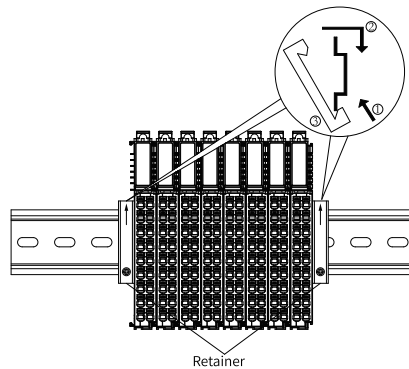
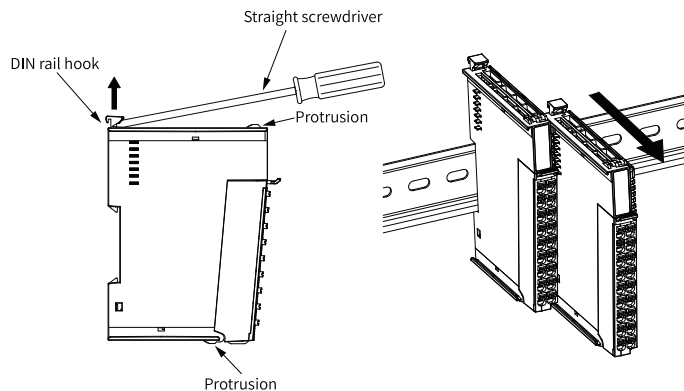

Figure 2-1 Installing end plate

Removing modules

Pry the DIN rail mounting hook upwards with a tool such as a slotted screwdriver, hold the protrusions and pull the module out straight forward. Then, press down the top of the mounting hook.



3 Electrical Installation

3.1 Cable Selection

The cable lug and cross sectional area shown in the following table are only for reference.

Material Name	Applicable cross sectional area of the cable		KST		Suzhou Yuanli	
	mm ²	AWG	Model	Crimping pliers	Model	Crimping pliers
Tubular lug	0.3	22	E0308	KST2000L	0308	YAC-5
	0.5	20	E0508			
	0.75	18	E7508			
	1.0	18	E1008			
	1.5	16	E1508			

If you use other types of tubular lug, crimp the lug to the cables according to the shape and dimension requirements shown in the figure below.

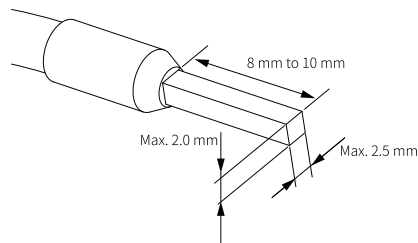

3.2 Terminal Definition

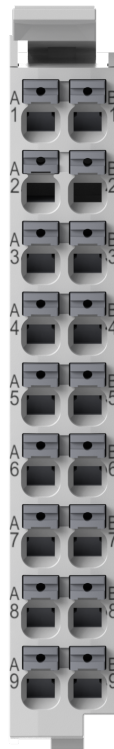

Left Signal Description	Left Signal	Left Terminal	Right Terminal	Right Signal	Right Signal Description
Channel 0 thermocouple input (+)	L0+	A1	B1	L0-	Channel 0 thermocouple input (-)
Empty terminal (unconnected)	•	A2	B2	•	Empty terminal (unconnected)
Channel 1 thermocouple input (+)	L1+	A3	B3	L1-	Channel 1 thermocouple input (-)
Thermal resistor (+)	RTD A	A4	B4	RTD B	Thermal resistor (-)
Input A for the external PT cold junction compensation (three-wire mode)	I+	A5	B5	I-	Input B for the external PT cold junction compensation (three-wire mode)
Channel 2 thermocouple input (+)	L2+	A6	B6	L2-	Channel 2 thermocouple input (-)
Empty terminal (unconnected)	•	A7	B7	•	Empty terminal (unconnected)
Channel 3 thermocouple input (+)	L3+	A8	B8	L3-	Channel 3 thermocouple input (-)
Empty terminal (unconnected)	•	A9	B9	PE	Connected with PE

3.3 Terminal Wiring

Wiring precautions

- Do not bundle the expansion cable together with power cables (with high voltage and large current) that produce strong interference signals; otherwise, the expansion cable may be influenced by noise, surge, or induction. Separate it from other cables and avoid cabling in parallel.
- Use recommended cables and adapter boards for connection. It is recommended that shielded cables be used as expansion cables to enhance anti-interference capacity.
- Apply single-point grounding for the shielding of shielded cable and solder sealed cable.
- This product cannot be connected to an external 24 V power supply. Failure to comply can result in module damage.

Circuit block diagram and wiring diagram

- Wiring for thermocouple sensors

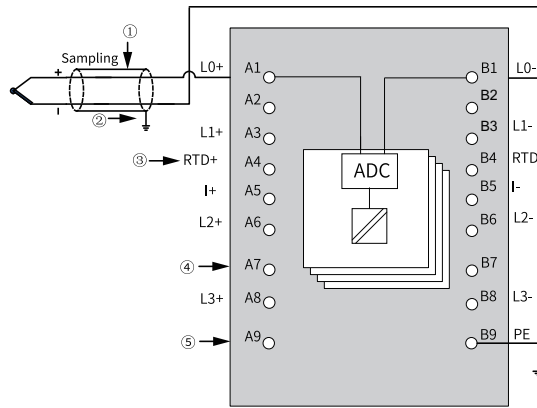

No.	Description
①	Use shielded compensating cables and connect the shield to PE. It is recommended to connect the PE terminal of the module to the external PE.
②	Compensating cables are required to extend thermocouples; otherwise, temperature measurements may be abnormal.
③	For internal cold junction compensation, terminals A4, A5, B4, and B5 need not to be wired.
④	A2, B2, A7, B7, and A9 are empty terminals with no electrical connections.
⑤	This product cannot be connected to an external 24 V power supply. Failure to comply can result in module damage.

• Wiring for external cold junction compensation

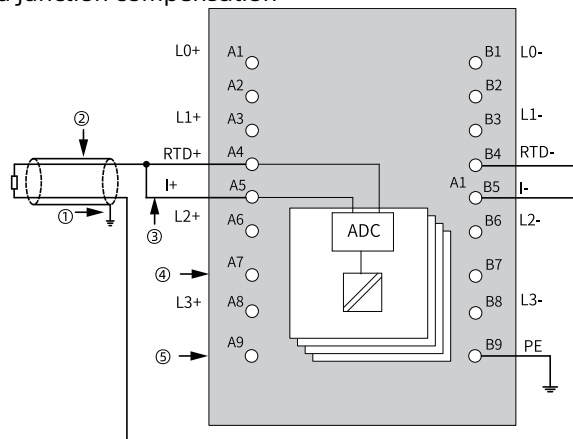

No.	Description
①	Use shielded compensating cables and connect the shield to PE. It is recommended to connect the PE terminal of the module to the external PE.
②	Compensating cables are required to extend thermocouples; otherwise, temperature measurements may be abnormal.
③	<p>The module supports two-wire, three-wire, and four-wire RTD sensors for external cold junction compensation</p> <ul style="list-style-type: none"> • For two-wire external cold junctions, connect the sensor cable (+) to terminal A4, and sensor cable (-) to terminal B4. Additional cables are required to short A4 to A5 and B4 to B5. In this configuration, cable impedance will affect measurement accuracy. • For three-wire external cold junctions, connect the two sensor cables (+) to terminals A4 and A5 respectively, and sensor cable (-) to terminal B4. Additional cables are required to short B4 to B5. • For four-wire external cold junctions, connect the two sensor cables (+) to terminals A4 and A5 respectively, and the two sensor cables (-) to terminals B4 and B5 respectively. No additional shorting is required.

No.	Description
④	A2, B2, A7, B7, and A9 are empty terminals with no electrical connections.
⑤	This product cannot be connected to an external 24 V power supply. Failure to comply can result in module damage.

4 Program Commissioning

The following is an example where AM600 is used as the master control module along with the GL20-4TC-ISO module in InoProShop.

1. Enable the AM600 series PLC as the EtherCAT master and add the GL20-RTU-ECT32 communication interface module.

- a. In the left **Devices** pane, double-click **Network Configuration** and click the AM600 figure in the upper left corner of the interface. Check the "EtherCAT Master" to enable the PLC as an EtherCAT master.

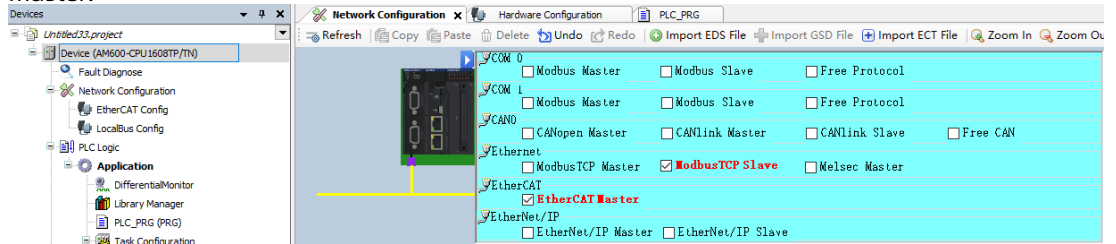

- b. Add the GL20-RTU-ECT32 communication interface module.

- Method 1: In the right **Network Devices List**, double-click "GL20-RTU-ECT32" to add the module.

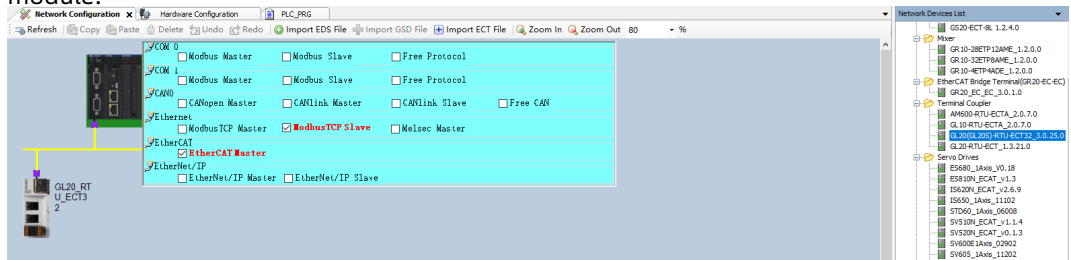

- Method 2: In the left **Devices** pane, right-click **ETHERCAT(EtherCAT Master SoftMotion)** and select **Add Device**. Select "GL20_RTU_ECT32_X.X.X.X" in the pop-up dialog box and click **Add Device**.

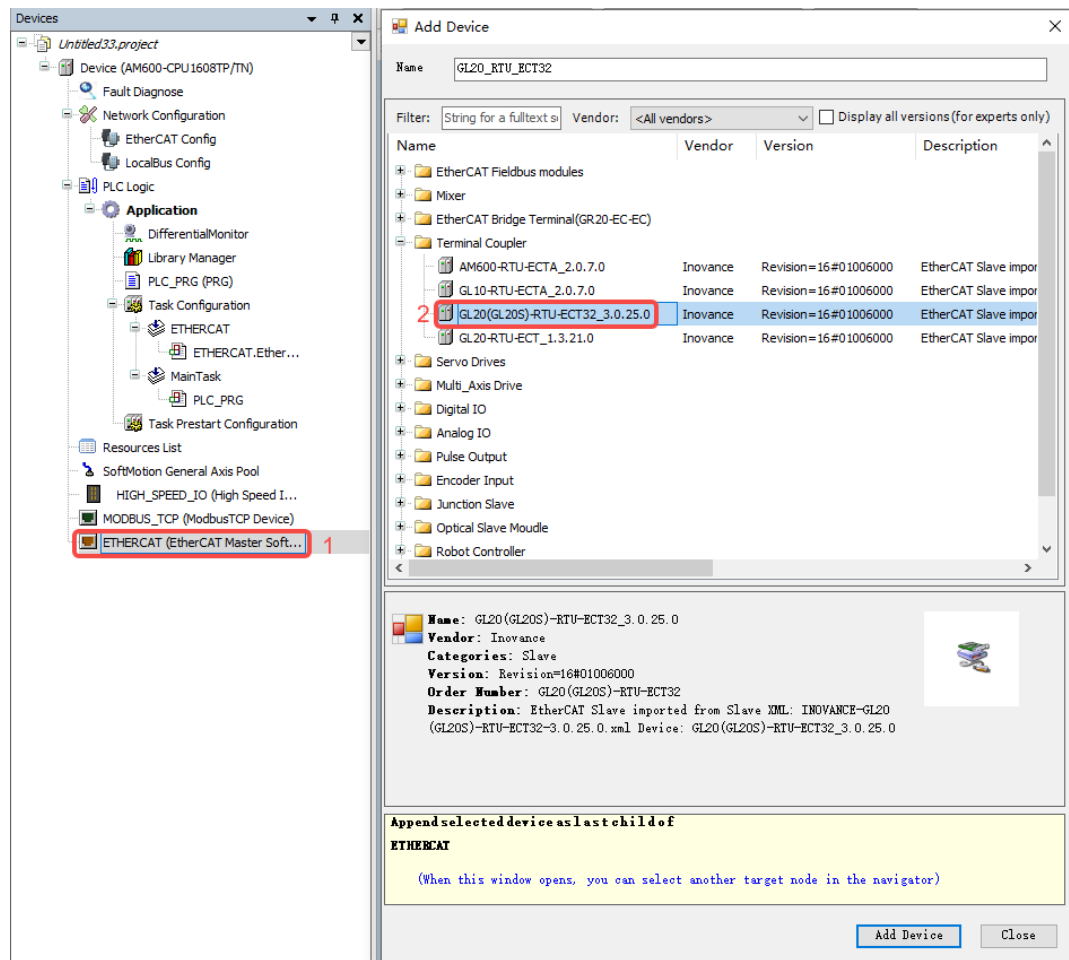

- Method 3: In the left **Devices** pane, right-click **ETHERCAT(EtherCAT Master SoftMotion)** and select **Scan For Devices**. Click **Scan Devices**, select the GL20-RTU-ECT32 module, and click **Copy Scan Device**.

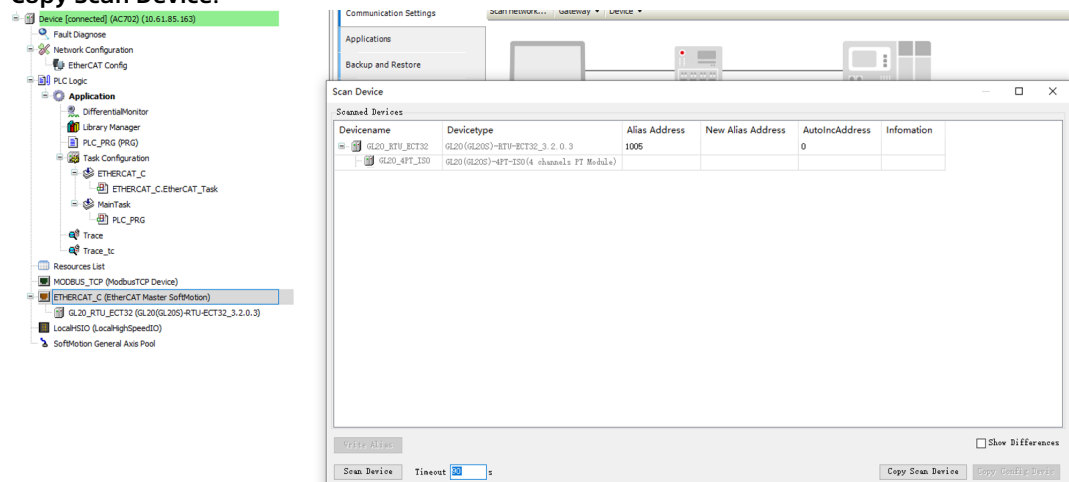

2. Add the GL20-4TC-ISO module.

- Method 1: Open the **Hardware Configuration** pane by double-clicking **EtherCAT Config** in the left **Devices** pane, or double-clicking the GL20-RTU-ECT32 figure in the **Network Configuration** pane. In the right **In\Output Module List**, double-click "GL20-4TC-ISO" or drag and place it after the GL20-RTU-ECT32 module.

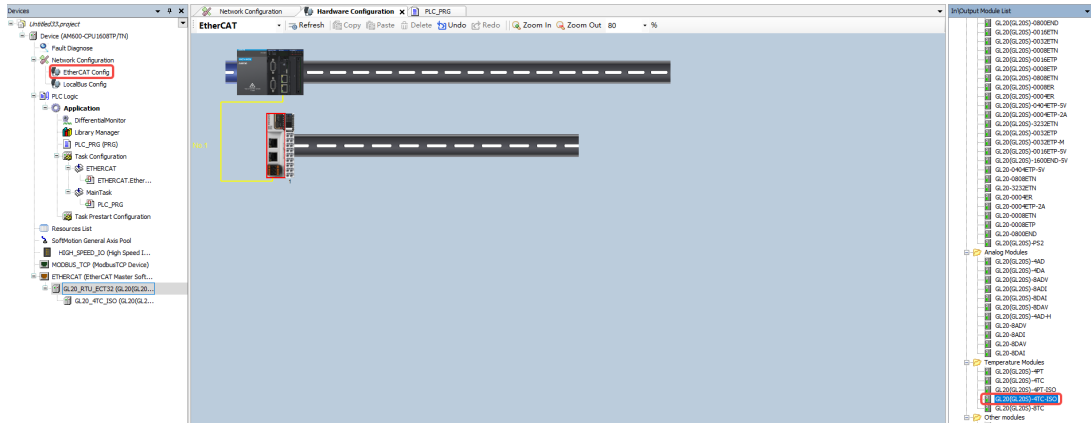

- Method 2: In the left **Devices** pane, right-click "GL20_RTU_ECT32" and select **Add Device**. Select "GL20-4TC-ISO" in the pop-up dialog box and click **Add Device**.

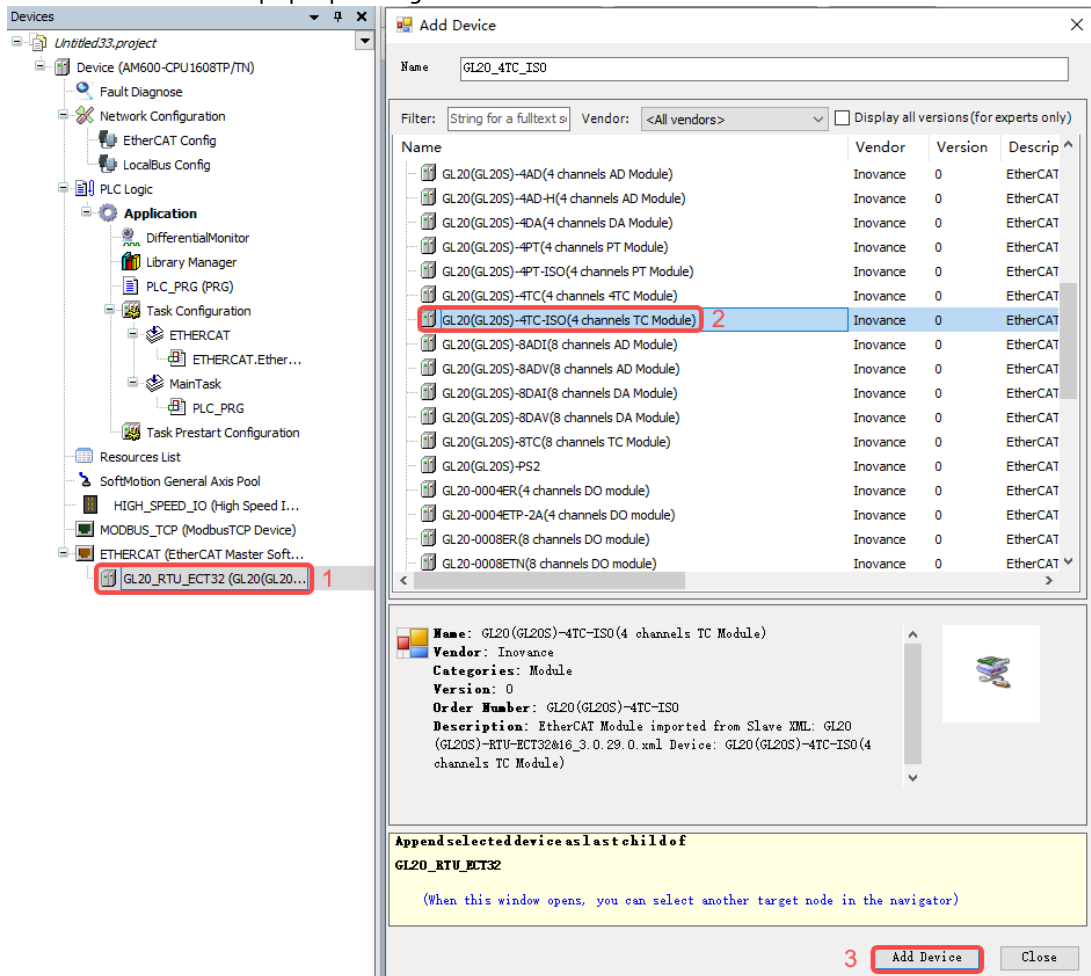

- Method 3: In the left **Devices** pane, right-click **ETHERCAT(EtherCAT Master SoftMotion)** and select **Scan For Devices**. Click **Scan Devices**, select the GL20-4TC-ISO module, and click **Copy Scan Device**.

3. Double-click the GL20-4TC-ISO module in the left **Devices** pane to set **GenericConfiguration**.

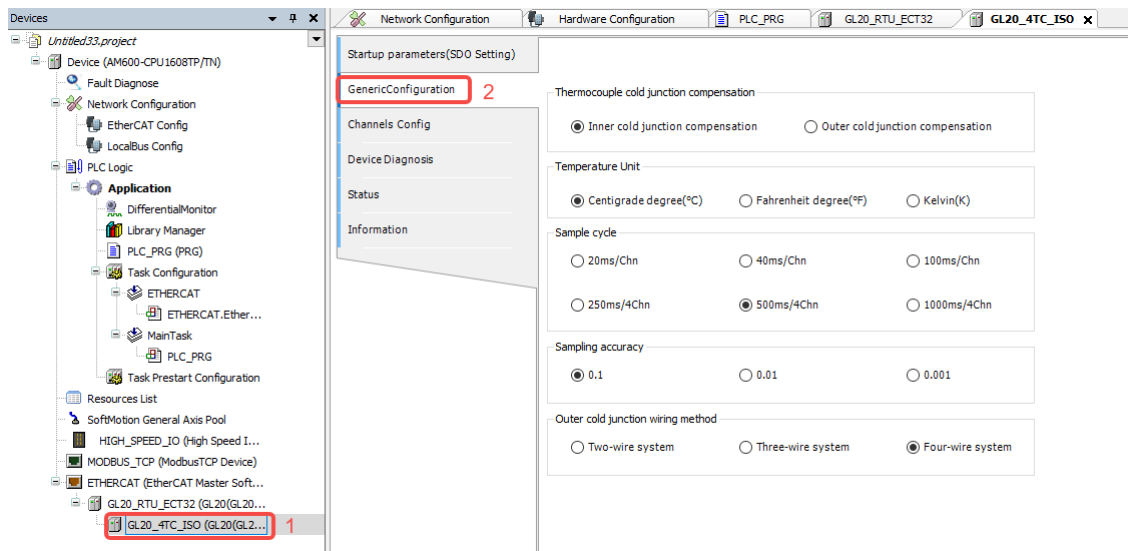

The parameters for channel configuration are shown in the following table.

Parameter	Description	Configuration
Cold junction compensation of thermocouple	Cold junction compensation method of thermocouple sensor	Supports internal and external cold junction compensation.
Temperature unit	The unit of temperature data collected by the module	Supported temperature units (by default is Centigrade degree): <ul style="list-style-type: none"> • Centigrade degree (°C) • Fahrenheit degree (°F) • Kelvin (K)
Sample cycle	Sampling and polling time of temperature data for the 4-channel module	Supported sampling cycles: <ul style="list-style-type: none"> • 20ms/Chn • 40ms/Chn • 100ms/Chn • 250ms/full channel (default) • 500ms/full channel (default) • 1000ms/full channel (default)
Wiring method	Wiring mode for external cold junction thermal resistor	Supported wiring modes: <ul style="list-style-type: none"> • Two-wire mode • Three-wire mode (default) • Four-wire mode
Resolution	Sampling accuracy	Supported resolutions: <ul style="list-style-type: none"> • 0.1 (default) • 0.01 • 0.001

4. Double-click the GL20-4PT-ISO module ① to set the **Channels Config** ②.

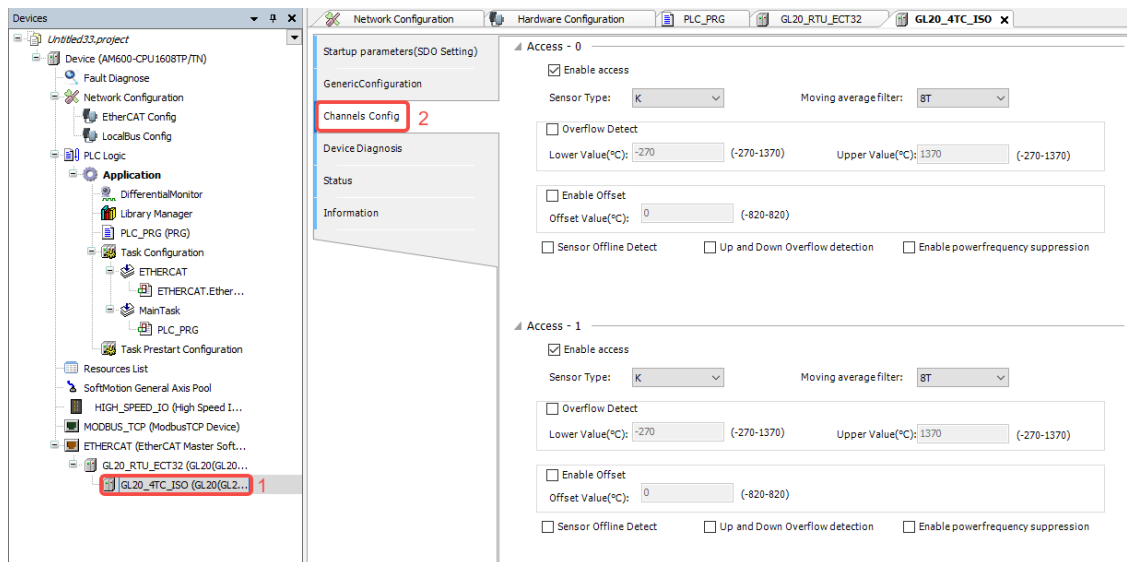

The parameters for channel configuration are shown in the following table.

Parameter	Description	Configuration
Enable access	Whether to enable the channel	Checked by default <ul style="list-style-type: none"> • Check to enable the channel • Uncheck to disable the channel
Sensor Type	Type of sensor connected to the module channel	Supports the following sensor types: K, J, E, B, N, S, and T. By default, the K-type thermocouple sensor is applied. Supported voltage measurement accuracy: ±100 mV
Moving average filter	Sampling filter time for module analog channel	Supported moving average filter time ("T" refers to the sampling cycle): None, 2T, 4T, 8T (default), 16T, 32T, 64T
Overflow detect	Whether to detect the channel data overflow	Unchecked by default <ul style="list-style-type: none"> • Check to enable overflow detection • Uncheck to disable overflow detection
Lower value	Lower limit of channel data	The lower limit depends on the temperature unit (by default is displayed in °C). The lower limit ranges from -270°C (default) to +1370°C.
Upper value	Upper limit of channel data	The upper limit depends on the temperature unit (by default is displayed in °C). The upper limit ranges from -270°C to 1370°C (default).
Enable offset	Whether to enable the channel data offset	Unchecked by default <ul style="list-style-type: none"> • Check to enable temperature offset • Uncheck to disable temperature offset
Offset value (°C)	Offset of channel data	Default is 0°C. The offset value ranges from -50% x (Max. - Min.) to +50% x (Max. - Min.).
Sensor offline detect	Whether to enable the open circuit detection of the channel	Unchecked by default <ul style="list-style-type: none"> • Check to enable sensor open circuit detection • Uncheck to disable sensor open circuit detection

Parameter	Description	Configuration
Up and down overflow detection	Whether to detect overflow and underflow of the channel data	Unchecked by default <ul style="list-style-type: none"> • Check to enable overflow/underflow detection • Uncheck to disable overflow detection
Power frequency suppression	Whether to suppress interference signals	Unchecked by default <ul style="list-style-type: none"> • When the power frequency suppression is enabled, the power frequency interference is significantly reduced, improving the signal-to-noise ratio. • When the power frequency suppression is disabled, the module only performs median filtering and moving average filtering on the signals. The median filter parameter is set to 9, and the moving average filter parameter can be configured as None, 2T, 4T, 8T, 16T, 32T, and 64T.

5. Create new variables.

- a. In the left **Devices** pane, double-click **PLC_PRG** ① and click  ② in the upper right corner to switch to table mode.

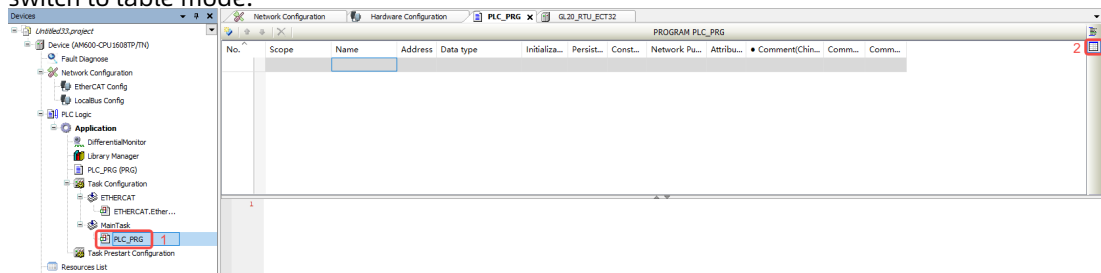

- b. Add custom input variables "GL20_4TC_ISO_CH0", "GL20_4TC_ISO_CH1", "GL20_4TC_ISO_CH2", and "GL20_4TC_ISO_CH3". Set the scope to **VAR** and data type to **REAL**, as shown below.

No.	Scope	Name	Address	Data type	Initializa...	Persist...	Const...	Network Pu...	Attribu...	• Comment(Chin...	Comm...	Comm...
1	VAR	GL20_4TC_ISO_CH0		REAL		<input type="checkbox"/>	<input type="checkbox"/>	Default				
2	VAR	GL20_4TC_ISO_CH1		REAL		<input type="checkbox"/>	<input type="checkbox"/>	Default				
3	VAR	GL20_4TC_ISO_CH2		REAL		<input type="checkbox"/>	<input type="checkbox"/>	Default				
4	VAR	GL20_4TC_ISO_CH3		REAL		<input type="checkbox"/>	<input type="checkbox"/>	Default				

6. Map variables to the corresponding input channels.

- a. In the left **Devices** pane, double-click **GL20_RTU_ECT32** ① and click the **EtherCAT I/O Mapping** tab ②.

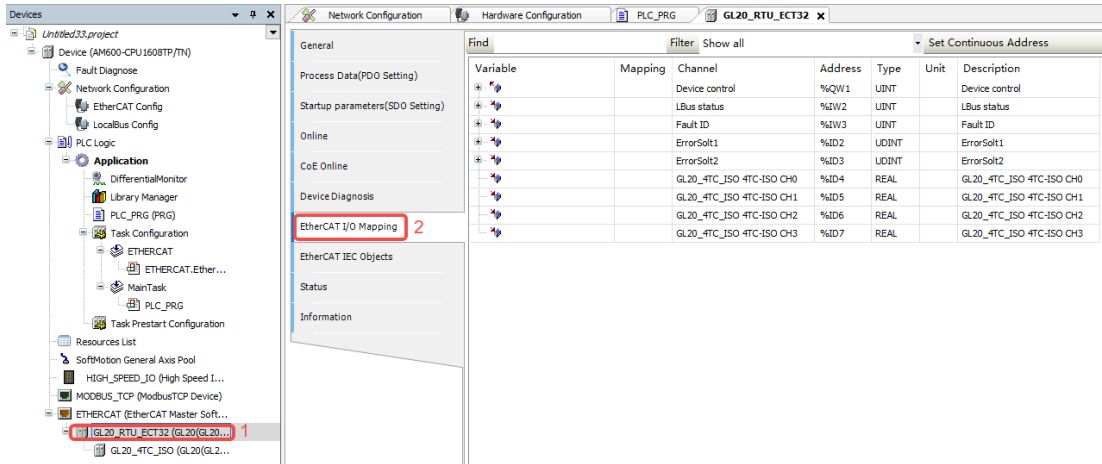

b. On the **EtherCAT I/O Mapping** tab, double-click a variable entry and click ① to open the **Input Assistant** dialog box. Choose **Application > PLC_PRG > specific variables** ② and click **OK**

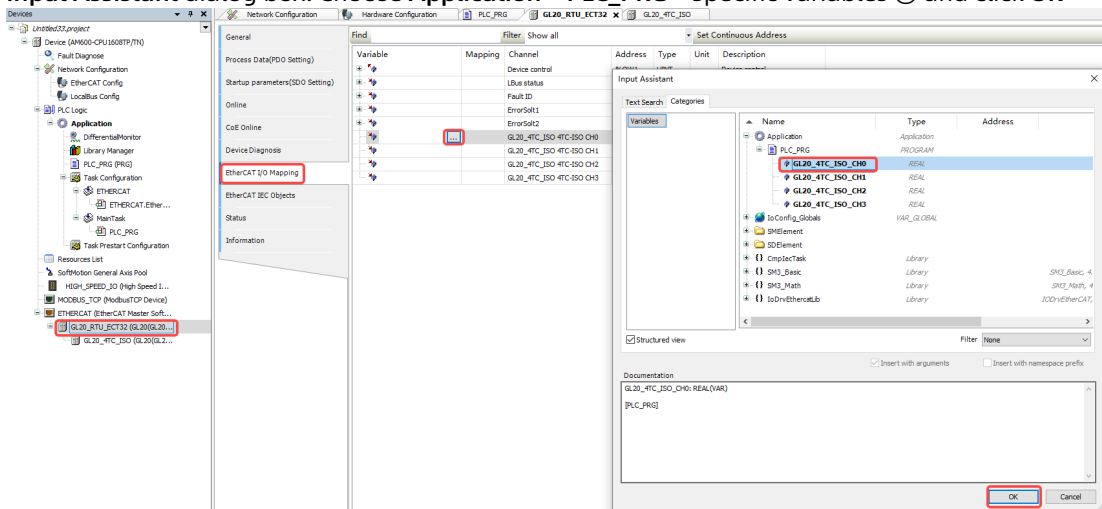



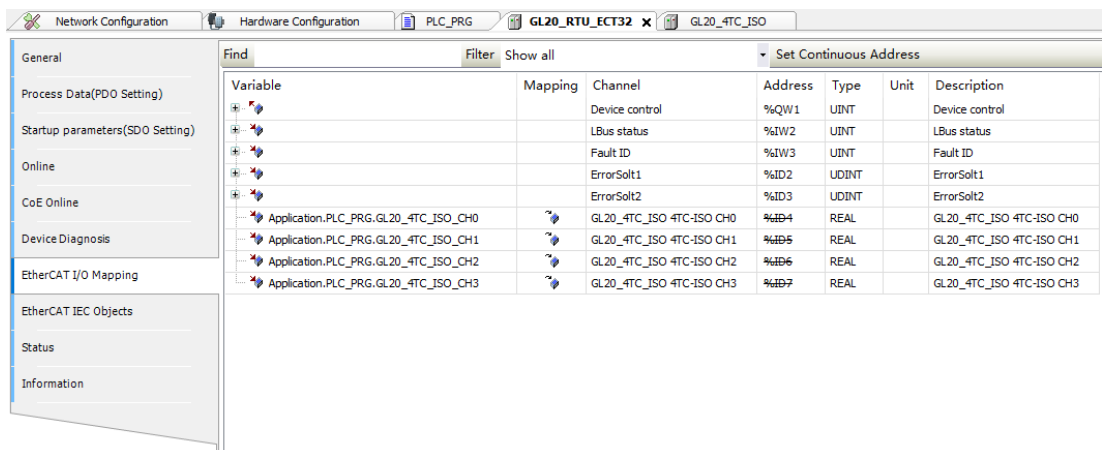

In the **EtherCAT I/O Mapping** tab, map the input variables "GL20_4TC_ISO_CH0", "GL20_4TC_ISO_CH1", "GL20_4TC_ISO_CH2", and "GL20_4TC_ISO_CH3" to the input channels of the configured module, as shown in the figure below.



7. Double-click **PLC_PRG** in the left **Devices** pane and complete the programming on the **PLC_PRG** page.

8. Check, compile, log in, download, and run the program.

- a. Click  on the toolbar at the top of the interface to check whether the program is correct.
- b. Click  on the toolbar to compile all the code into PLC executable code.
- c. Click  on the toolbar, and follow the interface prompts to log in to the PLC and download the program.
- d. Click  on the toolbar to execute the program.

5 Troubleshooting

When the ERR indicator is ON, it indicates that the module is faulty. The module reports a fault code. You can get the fault code through the diagnostic data object dictionary value displayed on the **CoE Online** interface, as shown below. For the module installed in slot n (n = 0 to 31), the object dictionary definition for index 0xA000+0x40*n is shown in the table below.

Index:Subindex	Name	Flags	Type	Value
* 16#1C00:16#00	Sync manager type	RO	USINT	
* 16#1C12:16#00	RxPDO assign	RO	USINT	
* 16#1C13:16#00	TxPDO assign	RO	USINT	
* 16#1C32:16#00	SM output parameter	RO	USINT	
* 16#1C33:16#00	SM input parameter	RO	USINT	
* 16#3010:16#00	Port 0 error counter	RO	USINT	
* 16#3011:16#00	Port 1 error counter	RO	USINT	
* 16#3012:16#00	ESC error counter	RO	USINT	
* 16#3016:16#00	Station address	RO	USINT	
... 16#3020:16#00	Fpga soft version	RO	UDINT	
* 16#3021:16#00	Module software version	RO	USINT	
* 16#5000:16#00	Disable Slot Control	RW	USINT	
... 16#5001:16#00	Disable Function Control	RW	UINT	
* 16#6000:16#00	4TC-ISO input	RO	USINT	
* 16#7000:16#00	4TC-ISO input	RO	USINT	
* 16#8000:16#00	4TC-ISO Module Configuration	RW	USINT	
* 16#8001:16#00	4TC-ISO Temperature Unit	RW	USINT	
* 16#8002:16#00	4TC-ISO module transform mode	RW	USINT	
* 16#8003:16#00	4TC-ISO module Filter	RW	USINT	
* 16#8004:16#00	4TC-ISO Sensor input Bias	RW	USINT	
* 16#8005:16#00	4TC-ISO Sensor input UpLimit	RW	USINT	
* 16#8006:16#00	4TC-ISO Sensor input DownLimit	RW	USINT	
* 16#8007:16#00	4TC-ISO Sensor input Detect	RW	USINT	
* 16#A000:16#00	4TC-ISO module Diagnosis information	RO	USINT	
... :16#01	Module Error Code	RO	UINT	
... :16#02	Channel Error Code CH0	RO	UINT	
... :16#03	Channel Error Code CH1	RO	UINT	
... :16#04	Channel Error Code CH2	RO	UINT	
... :16#05	Channel Error Code CH3	RO	UINT	
* 16#F000:16#00	Modular device profile	RO	USINT	
* 16#F030:16#00	Configured Module Ident List	RO	USINT	
* 16#F050:16#00	Detected Module Ident List	RO	USINT	

For the module in slot n (n = 0 to 31), the object dictionary definition for index 0xA000+0x40*n is shown in the table below.

Index	0xA000+0x40*n: 4TC Diag data				
Subindex	Name	Data Type	Access Type	Mapping	Default Value
0	Subindex 000	USINT	RO	NO	5
1	Module Error Code	UINT	RO	NO	0x0000
2	Channel Error Code CH0	UINT	RO	NO	0x0000
3	Channel Error Code CH1	UINT	RO	NO	0x0000
4	Channel Error Code CH2	UINT	RO	NO	0x0000
5	Channel Error Code CH3	UINT	RO	NO	0x0000

Note

The TC thermocouple input supports module fault detection and channel fault detection.

The module fault code is defined as follows:

Fault Code	Description	Solution
0x5021	ADC device fault	/
0x5031	Module external cold junction fault	Check the wiring for the external cold junction sensor.

The channel fault codes are defined as follows:

Fault Code	Description	Solution
0x6001	Channel open-circuited	Check the signal wiring and ensure the sensor type is correct.
0x6002	Channel short-circuited	This fault is not applicable to the GL20-4TC-ISO module.
0x6003	Channel data exceeds the upper limit.	Check the sensor, wiring, or reconfigure the upper limit.
0x6004	Channel data exceeds the lower limit.	Check the sensor, wiring, or reconfigure the upper limit.
0x6005	Overflow	Check whether the selected sensor range is exceeded.
0x6006	Underflow	Check whether the selected sensor range is undershot.
0x6008	Channel ADC fault	/
0x600A	Internal cold junction fault (such as disconnection and overflow/underflow)	/

6 Appendix

6.1 Appendix 1: Accuracy Calculation

Within the operating temperature range, when the temperature change rate is less than 0.3°C/min, it is necessary to wait 45 minutes before measuring. The accuracy of this product is shown below.

- Internal cold junction measurement accuracy = ADC sampling accuracy + Internal cold junction compensation error (related to the installation method)
 - It is recommended to install the module horizontally in upright position (refer to [“2.3 Installation Method” on page 13](#)) and use it adjacent to temperature modules within the operating temperature range. In this case, the cold junction compensation error is within ±3°C.
 - It is not recommended to use the module adjacent to modules that consume more than 3.5 W power, such as the GL20-3232ETN module.

The following table shows the internal cold junction compensation error.

Installation Direction	Adjacent Module Type	Cold Junction Compensation Error (-20°C to 0°C)	Cold Junction Compensation Error (0°C to 55°C)
Horizontal, upright	Temperature module	±3°C	±1.75°C
	Non-temperature module	±6.5°C	±4.5°C
Non-horizontal, upright	Temperature module	±5.5°C	±4°C
	Non-temperature module	±5.5°C	±4.5°C

The module is equipped with four built-in temperature sensors for internal cold junction compensation.

- External cold junction measurement accuracy = ADC sampling accuracy + External cold junction compensation error (±1°C) + Sensor error (related to the installation method)

The external cold junction measurement principle is shown below. The module requires a 45-minute warm-up after power-on before measurement.

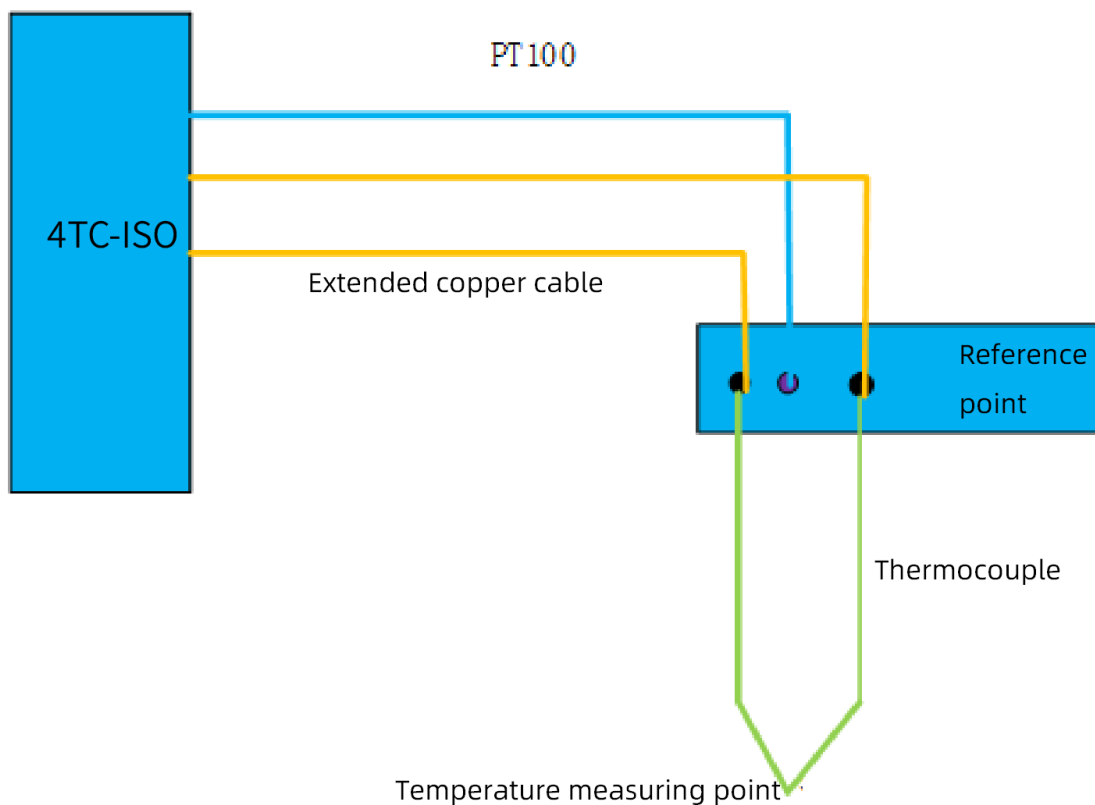

The following table shows the thermocouple detection range and ADC sampling accuracy.

Sensor Type	Detection Range	Detection Accuracy
B	200.0°C to 1800.0°C, 392.0°F to 3272.0°F	$\geq \pm 5^\circ\text{C}@200^\circ\text{C} \leq T \leq 400^\circ\text{C}$ $< \pm 5^\circ\text{C}@400^\circ\text{C} \leq T \leq 750^\circ\text{C}$ $< \pm 3^\circ\text{C}@750^\circ\text{C} \leq T \leq 1200^\circ\text{C}$ $< \pm 3.5^\circ\text{C}@1200^\circ\text{C} \leq T \leq 1800^\circ\text{C}$
E	-270.0°C to +1000.0°C, -454.0°F to +1832.0°F	$\geq \pm 1^\circ\text{C}@-270^\circ\text{C} \leq T \leq -200^\circ\text{C}$ $< \pm 1^\circ\text{C}@-200^\circ\text{C} \leq T \leq 400^\circ\text{C}$ $< \pm 1.5^\circ\text{C}@400^\circ\text{C} \leq T \leq 1000^\circ\text{C}$
N	-200.0°C to +1300.0°C, -328.0°F to +2372.0°F	$< \pm 2^\circ\text{C}@-200^\circ\text{C} \leq T \leq -150^\circ\text{C}$ $< \pm 1.5^\circ\text{C}@-150^\circ\text{C} \leq T \leq +750^\circ\text{C}$ $< \pm 0.2\%$ of displayed value @750°C ≤ T ≤ 1300°C
J	-210.0°C to +1200.0°C, -346.0°F to +2192.0°F	$\geq \pm 1^\circ\text{C}@-210^\circ\text{C} \leq T \leq -100^\circ\text{C}$ $< \pm 1^\circ\text{C}@-100^\circ\text{C} \leq T \leq 500^\circ\text{C}$ $< \pm 0.2\%$ of displayed value @500°C ≤ T ≤ 1200°C
K	-270.0°C to +1370.0°C, -454.0°F to +2498.0°F	$\geq \pm 1.5^\circ\text{C}@-270^\circ\text{C} \leq T \leq -200^\circ\text{C}$ $< \pm 1.5^\circ\text{C}@-200^\circ\text{C} \leq T \leq -100^\circ\text{C}$ $< \pm 1^\circ\text{C}@-100^\circ\text{C} \leq T \leq +500^\circ\text{C}$ $< \pm 0.2\%$ of displayed value @500°C ≤ T ≤ 1300°C $\geq \pm 2.6^\circ\text{C}@1300^\circ\text{C} \leq T \leq 1370^\circ\text{C}$

Sensor Type	Detection Range	Detection Accuracy
R	-50.0°C to +1765.0°C, -58.0°F to +3209.0°F	≥ ±4°C@-50°C ≤ T ≤ 0°C < ±4°C@0°C ≤ T ≤ 250°C < ±2°C@250°C ≤ T ≤ 500°C < ±3.5°C@500°C ≤ T ≤ 1700°C ≥ ±3.5°C@1700°C ≤ T ≤ 1765°C
S	-50.0°C to +1765.0°C, -58.0°F to +3209.0°F	≥ ±4°C@-50°C ≤ T ≤ 0°C < ±4°C@0°C ≤ T ≤ 250°C < ±2°C@250°C ≤ T ≤ 500°C < ±3.5°C@500°C ≤ T ≤ 1700°C ≥ ±3.5°C@1700°C ≤ T ≤ 1768°C
T	-270.0°C to +400.0°C, -454.0°F to +752.0°F	≥ ±1°C@-270°C ≤ T ≤ -200°C < ±1°C@-200°C ≤ T ≤ +400°C

6.2 Appendix 2: Object Dictionary Definition

Overview

Name: GL20-4TC-ISO Module

Module category: Temperature Measure

Module identification code: 10F41056

The GL20-4TC-ISO module is used for thermocouple temperature collection. It is equipped with four independent channels for simultaneous temperature collection. The configuration of each channel is independent from each other.

Process Data

For the module in slot n (n = 0 to 31), the object dictionary definition for index 0x1A03+0x08*n is shown in the table below.

Index	0x1A03+0x08*n: 4TC-ISO Input Mapping				
Subindex	Name	Data Type	Access Type	Mapping	Default Value
0	Number of entries	USINT	RO	NO	4
1	1st application object	UDINT	RO	NO	0x60000120
2	2nd application object	UDINT	RO	NO	0x60000220
3	3rd application object	UDINT	RO	NO	0x60000320
4	4th application object	UDINT	RO	NO	0x60000420

For the module in slot n (n = 0 to 31), the object dictionary definition for index 0x1A04+0x08*n is shown in the table below.

Index	0x1A04+0x08*n: 4TC-ISO Diagnosis Information Mapping				
Subindex	Name	Data Type	Access Type	Mapping	Default Value
0	Number of entries	USINT	RO	NO	5
1	1st application object	UDINT	RO	NO	0xA0000110
2	2nd application object	UDINT	RO	NO	0xA0000210
3	3rd application object	UDINT	RO	NO	0xA0000310

Index	0x1A04+0x08*n: 4TC-ISO Diagnosis Information Mapping				
Subindex	Name	Data Type	Access Type	Mapping	Default Value
4	4th application object	UDINT	RO	NO	0xA0000410
5	5th application object	UDINT	RO	NO	0xA0000510

Index	0x1602+0x08*n: 4TC-ISO Output Mapping				
Subindex	Name	Data Type	Access Type	Mapping	Default Value
0	Number of entries	USINT	RO	NO	1
1	1st application object	UDINT	RO	NO	0x70000110

For the module in slot n (n = 0 to 31), the object dictionary definition for index 0x6000+0x40*n is shown in the table below.

Index	0x6000+0x40*n: 4TC-ISO Input				
Subindex	Name	Data Type	Access Type	Mapping	Default Value
0	Number of entries	USINT	RO	NO	4
1	4TC-ISO CH0	REAL	RO	YES	0x00000000
2	4TC-ISO CH1	REAL	RO	YES	0x00000000
3	4TC-ISO CH2	REAL	RO	YES	0x00000000
4	4TC-ISO CH3	REAL	RO	YES	0x00000000

Note

Each subindex represents the detected TC thermocouple temperature of a channel.

For the module in slot n (n = 0 to 31), the object dictionary definition for index 0x7000+0x40*n is shown in the table below.

Index	0x7000+0x40*n: 4TC-ISO Input				
Subindex	Name	Data Type	Access Type	Mapping	Default Value
0	Number of entries	USINT	RO	NO	4
1	4TC-ISO Control Word	UINT	RO	YES	0x0000
2	Reserve0	UINT	RO	YES	0x0000
3	Reserve1	UINT	RO	YES	0x0000
4	Reserve2	UINT	RO	YES	0x0000

Subindex 1: 4TC-ISO Control Word

Parameter	Description
4TC-ISO Module Control	Module control words that support process data output configuration <ul style="list-style-type: none"> • 0: Default configuration (output temperature and resistance values) • 1: ADC source code upload mode • 2: Measurement side voltage • 3: Voltage after calibration • 4: Cold junction resistance • 5: Cold junction temperature • 6: Measured temperature

Configuration Data

For the module in slot n (n = 0 to 31), the object dictionary definition for index 0x8000+0x40*n is shown in the table below.

Index	0x8000+0x40*n: 4TC-ISO Module Configuration				
Subindex	Name	Data Type	Access Type	Mapping	Default Value
0	Number of entries	USINT	RO	NO	4
1	4TC-ISO Sampling Time	USINT	RW	NO	0x11
2	4TC-ISO ExtCold Wiring Method	USINT	RW	NO	0x0002
3	4TC-ISO Cold Reference Configuration	USINT	RW	NO	0x0000
4	Reserve0	USINT	RW	NO	0x0000

Parameter	Description
4TC-ISO Sampling Time	Sampling cycles can be divided in the following two ways: Single channel <ul style="list-style-type: none"> • 0x00: 20ms/Chn • 0x01: 40ms/Chn • 0x02: 100ms/Chn Full channel <ul style="list-style-type: none"> • 0x10: 250ms/4Chn • 0x11: 500ms/4Chn (default) • 0x12: 1000ms/4Chn
4TC-ISO ExtCold Wiring Method	External cold junctions can be wired in the following three modes: <ul style="list-style-type: none"> • 0: Two-wire mode • 1: Three-wire mode (default) • 2: Four-wire mode
4TC-ISO Cold Reference Configuration	Cold junction compensation can be divided in the following two types: <ul style="list-style-type: none"> • 0: Internal cold junction compensation (default) • 1: External cold junction compensation

For the module in slot n (n = 0 to 31), the object dictionary definition for index 0x8001+0x40*n is shown in the table below.

Index	0x8001+0x40*n: 4TC-ISO Temperature Unit				
Subindex	Name	Data Type	Access Type	Mapping	Default Value
0	Number of entries	USINT	RW	NO	0x0000
1	4TC-ISO Temperature Unit	USINT	RW	NO	0x0000
2	4TC-ISO Resolution	USINT	RW	NO	0x0000
3	Reserve1	USINT	RW	NO	0x0000
4	Reserve2	USINT	RW	NO	0x0000

Parameter	Description
4TC-ISO Temperature Unit	The supported temperature units are shown below (default is °C). <ul style="list-style-type: none"> • 0: Centigrade degree (°C) • 1: Fahrenheit degree (°F) • 2: Kelvin (K)
4TC-ISO Resolution	The supported resolution options are shown below. <ul style="list-style-type: none"> • 0: 0.1 (default) • 1: 0.01 • 2: 0.001

For the module in slot n (n = 0 to 31), the object dictionary definition for index 0x8002+0x40*n is shown in the table below.

Index	0x8002+0x40*n: 4TC-ISO Module Transform Mode				
Subindex	Name	Data Type	Access Type	Mapping	Default Value
0	Number of entries	USINT	RO	NO	4
1	4TC-ISO module CH0 transform mode	USINT	RW	NO	0xC0
2	4TC-ISO module CH1 transform mode	USINT	RW	NO	0xC0
3	4TC-ISO module CH2 transform mode	USINT	RW	NO	0xC0
4	4TC-ISO module CH3 transform mode	USINT	RW	NO	0xC0

Each subindex represents whether to enable the temperature detection channel and the thermocouple sensor model. Default is 0xC0, which corresponds to enabling K-type thermocouple. In this mode, a fault is reported and triggers shutdown. The setting rule is as follows:

Bit	Description
Bit 7	Determines whether to enable temperature detection channel <ul style="list-style-type: none"> • 0: Disabled • 1: Enabled
Bit 6	Reserved
Bit5:0	Thermocouple sensor models include: <ul style="list-style-type: none"> • 0: K • 1: J • 2: E (default) • 3: B • 4: N • 5: R • 6: S • 7: T • 0x10: ±100 mV

For the module in slot n (n = 0 to 31), the object dictionary definition for index 0x8003+0x40*n is shown in the table below.

Index	0x8003+0x40*n: 4TC-ISO Module Filter				
Subindex	Name	Data Type	Access Type	Mapping	Default Value
0	Number of entries	USINT	RO	NO	4
1	4TC-ISO Module CH0 Filter	USINT	RW	NO	0x04
2	4TC-ISO Module CH1 Filter	USINT	RW	NO	0x04
3	4TC-ISO Module CH2 Filter	USINT	RW	NO	0x04
4	4TC-ISO Module CH3 Filter	USINT	RW	NO	0x04

Note

The moving average filter parameter of the temperature detection channel ranges from 1 (0) to 7 (64T), indicating the multiple of the sampling cycle. The default value is 4 (8T).

Subindex 1: 4PT module CH0 Filter (The usage of subindices 2, 3, and 4 is the same as subindex 1)

Bit	Description
Bit 7: 5	Power frequency suppression <ul style="list-style-type: none"> • 0: Disabled • 1: Enabled
Bit 4: 0	CH0 channel filter parameter (configured by the moving average filter parameter): <ul style="list-style-type: none"> • 1: None • 2: 2T • 3: 4T • 4: 8T • 5: 16T • 6: 32T • 7: 64T Note: "T" refers to the sampling cycle.

For the module in slot n (n = 0 to 31), the object dictionary definition for index 0x8004+0x40*n is shown in the table below.

Index	0x8004+0x40*n: 4TC-ISO Sensor Input Bias				
Subindex	Name	Data Type	Access Type	Mapping	Default Value
0	Number of entries	USINT	RO	NO	4
1	4TC-ISO Module CH0 Bias	INT16	RW	NO	0x00000000
2	4TC-ISO Module CH1 Bias	INT16	RW	NO	0x00000000
3	4TC-ISO Module CH2 Bias	INT16	RW	NO	0x00000000
4	4TC-ISO Module CH3 Bias	INT16	RW	NO	0x00000000

Note

The range of the offset parameter for the temperature detection channel is $\pm 50\% \times$ full range. The unit of 0.1 °C/°F/K and the default value is 0.

Sensor Type	Full-Range Temperature Detection Range		
	Centigrade degree (°C)	Fahrenheit degree (°F)	Kelvin (K)
B type	200.0 to 1800.0	392.0 to 3272.0	473.15 to 2073.15
E type	-270.0 to +1000.0	-454.0 to +1832.0	3.15 to 1273.15
N type	-200.0 to +1300.0	-328.0 to +2372.0	73.15 to 1573.15
J type	-210.0 to +1200.0	-346.0 to +2192.0	63.15 to 1473.15
K type	-270.0 to +1370.0	-454.0 to +2498.0	3.15 to 1643.15
R type	-50.0 to +1765.0	-58.0 to +3209.0	223.15 to 2038.15
S type	-50.0 to +1765.0	-58.0 to +3209.0	223.15 to 2038.15
T type	-270.0 to +400.0	-454.0 to +752.0	3.15 to 673.15

For the module in slot n (n = 0 to 31), the object dictionary definition for index 0x8005+0x40*n is shown in the table below.

Index	0x8005+0x40*n: 4TC-ISO Sensor Input UpLimit				
Subindex	Name	Data Type	Access Type	Mapping	Default Value
0	Number of entries	USINT	RO	NO	4
1	4TC-ISO Sensor Input CH0 UpLimit	INT	RW	NO	0x3584
2	4TC-ISO Sensor Input CH1 UpLimit	INT	RW	NO	0x3584
3	4TC-ISO Sensor Input CH2 UpLimit	INT	RW	NO	0x3584
4	4TC-ISO Sensor Input CH3 UpLimit	INT	RW	NO	0x3584

Note

The subindex represents the upper limit parameter of the temperature detection channel with a unit of 0.1 °C/°F. The range is same as the setting temperature range of the current mode. The default value is the maximum of the setting temperature range of the current mode.

For the module in slot n (n = 0 to 31), the object dictionary definition for index 0x8006+0x40*n is shown in the table below.

Index	0x8006+0x40*n: 4TC-ISO Sensor Input DownLimit				
Subindex	Name	Data Type	Access Type	Mapping	Default Value
0	Number of entries	USINT	RO	NO	4
1	4TC-ISO Sensor Input CH0 DownLimit	INT	RW	NO	0xF574
2	4TC-ISO Sensor Input CH1 DownLimit	INT	RW	NO	0xF574
3	4TC-ISO Sensor Input CH2 DownLimit	INT	RW	NO	0xF574
4	4TC-ISO Sensor Input CH3 DownLimit	INT	RW	NO	0xF574

Note

The subindex represents the lower limit parameter of the temperature detection channel with a unit of 0.1°C/°F. The range is same as the setting temperature range of the current mode. The default value is the minimum value of the setting temperature range of the current mode.

For the module in slot n (n = 0 to 31), the object dictionary definition for index 0x8007+0x40*n is shown in the table below.

Index	0x8007+0x40*n: 4TC-ISO Sensor Input Detect				
Subindex	Name	Data Type	Access Type	Mapping	Default Value
0	Number of entries	USINT	RO	NO	4
1	4TC-ISO Sensor Input CH0 Detect	USINT	RW	NO	0x0000
2	4TC-ISO Sensor Input CH1 Detect	USINT	RW	NO	0x0000
3	4TC-ISO Sensor Input CH2 Detect	USINT	RW	NO	0x0000
4	4TC-ISO Sensor Input CH3 Detect	USINT	RW	NO	0x0000

The subindex represents the input functions and diagnostic option parameters for the temperature detection channel. Default is 0x0000, indicating temperature offset, wire break detection, and over-limit detection are disabled. The setting rule is as follows:

Bit	Description
Bit 4 to Bit 7	Reserved
Bit 3	Overflow/underflow detection <ul style="list-style-type: none"> • 0: Disabled • 1: Enabled

Bit	Description
Bit 2	Limit exceeded detection <ul style="list-style-type: none"> • 0: Disabled • 1: Enabled
Bit 1	Disconnection detection <ul style="list-style-type: none"> • 0: Disabled • 1: Enabled
Bit 0	Temperature offset <ul style="list-style-type: none"> • 0: Disabled • 1: Enabled

6.3 Appendix 3: Version Matching Information

The version matching information is shown in the following table.

Product Name:	Firmware Version	Device Description File (.xml)
This module	Board software: 4.0.4.0 and later Logic software: 4.1.0.0 and later	-
GL20-RTU-ECT32 series communication interface module	Logic software: 0.1.4.5 and later	3.0.30.0 and later

Note

You can get the firmware of the module and the firmware of communication interface module from Inovance technical support, and download XML files and InoProShop from <https://www.inovance.com>.

Service and Support

Should you encounter a safety accident during the use or operation of the product, or face challenges in operating and maintaining the equipment, which remain unresolved after the relevant documentation is consulted, we provide multiple channels to ensure prompt resolution:

- Channel #1: Contact service@inovance.com.
- Channel #2: Visit <https://www.inovance.com/global> to access document downloads, after-sales support, spare parts ordering, repair applications, and authenticity verification services.
- Channel #3: Download My Inovance app (<https://zshc-eu.inovance.com/download-pc/>) where you can access products info and documentation, and query product parameters.

We are committed to providing you with quick and professional technical support, and we look forward to your satisfaction and trust.



Copyright © Shenzhen Inovance Technology Co., Ltd.

PS00021374A00

Shenzhen Inovance Technology Co., Ltd.

www.inovance.com

Suzhou Inovance Technology Co., Ltd.

www.inovance.com

Add.: Inovance Headquarters Tower, High-tech Industrial Park,
Guanlan Street, Longhua New District,
Shenzhen 518000, P.R. China

Tel: (0755) 2979 9595

Fax: (0755) 2961 9897

Add.: No. 52, Tian E Dang Road, Wuzhong District, 215104,
Suzhou City, Jiangsu Province, P.R. China

Tel: (0512) 6637 6666

Fax: (0512) 6285 6720