



GL20-8TC Series Thermocouple Input Temperature Detection Module User Guide



Industrial
Automation



Intelligent
Elevator



New Energy
Vehicle



Industrial
Robot



Rail
Transit



Data code PS00019553A00

Legal Information

Copyright

Copyright © Shenzhen Inovance Technology Co., Ltd. 2024 All rights reserved

This documentation is the exclusive property of Shenzhen Inovance Technology Co., Ltd. No individual or entity may excerpt, reproduce, modify, translate, or distribute any content herein without written consent from Inovance.

Legal action will be taken against infringement.

Trademarks

INOVANCE is a registered trademark of Shenzhen Inovance Technology Co., Ltd. and its affiliates. All other trademarks or registered trademarks mentioned in this documentation are the property of their respective owners. Unauthorized use of these trademarks by third parties for any purpose without written authorization could violate the rights of their owners.

Disclaimer of Liability

Due to continuous updates and improvements of products and technologies, the content of this documentation may not fully match the actual products. In the event of any discrepancies, the actual products shall prevail.

The contents are subject to change without notice due to product upgrade.

Waste Disposal

The storage, use, and disposal of this product (including optional accessories) must comply with local laws and regulations.

Qualified Personnel

The product/system described in this documentation may be operated only by personnel qualified for the specific task in accordance with the relevant documentation, in particular its warning notices and safety instructions. Qualified personnel can identify the risks of the product/system and prevent possible dangers.

Proper Use of the Product

Proper transportation, storage, assembly, installation, commissioning, operation, and maintenance are required to ensure the safe operation of the product without any problems. The required ambient conditions must be met. All operations must follow the guidelines provided in this documentation.

Preface

Introduction

The GL20-8TC is an 8-channel thermocouple input temperature detection module. It can be used with GL20 series communication interface modules, such as GL20-RTU-ECT32.

This guide describes the mechanical installation, electrical installation, program commissioning, troubleshooting, and version matching information of the product.

Standards Compliance

The following table lists the certifications, directives, and standards that the product may comply with. For details about the acquired certificates, see the certification marks on the product nameplate.

Certification	Directive		Standard
CE Certification	EMC Directive	2014/30/EU	24 VDC products: EN 61131-2 220 VAC products: EN 61131-2 EN 61000-3-2 EN 61000-3-3
	LVD Directive	2014/35/EU	EN 61010-1 EN 61010-2-201
	RoHS Directive	2011/65/EU amended by (EU)2015/863	EN IEC 63000
UL/cUL Certification	-		UL 61010-1 UL 61010-2-201 CAN/CSA-C22.2 No. 61010-1 CSA C22.2 NO. 61010-2-201
KCC Certification	-		-
EAC Certification	-		-
UKCA Certification	Safety Regulations	Electrical Equipment (Safety) Regulations 2016	EN 61010-1 EN 61010-2-201
	EMC Regulations	Electromagnetic Compatibility Regulations 2016	24 VDC products: EN 61131-2 220 VAC products: EN 61131-2 EN 61000-3-2 EN 61000-3-3
	RoHS Regulations	Directive (RoHS) Regulations 2012	EN IEC 63000

More Data

Name	Code	Description
GL20-RTU-ECT32 Series Communication Interface Module User Guide	PS00013434	Introduces the installation, wiring, and other information of the product.
GL20-8TC Series Thermocouple Input Temperature Detection Module User Guide (This guide)	PS00019553	Introduces the mechanical installation, electrical installation, program commissioning, troubleshooting, and version matching information of the product.

Revision History

Date	Version	Revision
September 2025	A00	Initial release.

Access to the Guide

This guide is not delivered with the product. You can obtain the PDF version in the following ways

- Do keyword search under Service and Support at www.inovance.com.
- **QR code:** Scan the QR code on the product with your smart phone.
- **My Inovance APP:** Scan the QR code below to install the app, where you can search for and download user guides.



Warranty Disclaimer

Inovance provides warranty service within the warranty period (as specified in your order) for any fault or damage that is not caused by improper operation of the user. You will be charged for any repair work after the warranty period expires.

Within the warranty period, maintenance fee will be charged for the following damage:

- Damage caused by operations not following the instructions in the user guide
- Damage caused by fire, flood, or unusual voltage
- Damage caused by unintended use of the product
- Damage caused by use beyond the specified scope of application of the product
- Damage or secondary damage caused by force majeure (natural disaster, earthquake, and lightning strike)

The maintenance is charged according to the latest Price List of Inovance. If otherwise agreed upon, the terms and conditions in the agreement shall prevail.

For details, see Product Warranty Card.

1 General Safety Rules

1.1 Fundamental Safety Instructions

Safety Precautions

1. Read and follow the safety instructions when installing, operating, and maintaining the equipment.
2. To ensure your safety and prevent damage to the equipment, follow the marks on the equipment and all the safety instructions in this guide.
3. "CAUTION", "WARNING", and "DANGER" items in this guide do not indicate all safety precautions that need to be followed; instead, they just supplement the safety precautions.
4. Use this equipment according to the designated environment requirements; otherwise, a fault may occur. Malfunction or damage caused by improper use is not covered by warranty.
5. Inovance shall take no responsibility for any personal injury or property damage caused by improper use.

Safety Levels and Definitions



"DANGER" indicates that failure to comply with the notice will result in death or severe personal injuries.



"WARNING" indicates that failure to comply with the notice may result in death or severe personal injuries.



"CAUTION" indicates that failure to comply with the notice may result in minor personal injuries or equipment damage. Keep this user guide properly for future use and deliver it to the end user.

Control System Design	
	<ul style="list-style-type: none">• Provide a safety circuit outside the PLC so that the control system can still work safely once external power failure or controller fault occurs.• Add an external fuse or circuit breaker to prevent the module from smoking or catching fire due to long-time overcurrent caused by operation above rated current or load short-circuit.
	<ul style="list-style-type: none">• An emergency stop circuit, a protection circuit, a forward/reverse operation interlocked circuit, and an upper position limit and lower position limit interlocked circuit must be set in the external circuits of PLC to prevent damage to the equipment.• To ensure safe operation, for the output signals that may cause critical accidents, use external protection circuit and safety mechanism.• Once the CPU of the PLC detects an exception in the system, all outputs may be closed; however, when a fault occurs in the controller circuit, the output may not be under control. Therefore, it is necessary to design an appropriate external control circuit to ensure normal operation.• If the output units such as relays or transistors are damaged, the output may fail to switch between ON and OFF states according to the commands.• The PLC is designed to be used in an indoor electrical environment compliant with overvoltage category II. The power supply must have a system-level surge protector to ensure that overvoltage caused by lightning shock cannot be applied to power supply input terminals, signal input terminals, and control output terminals of the PLC, therefore preventing damage to the product.

Installation

- Installation must be carried out by skilled personal who have undergone specialized electrical training and possess comprehensive electrical expertise.
- Disconnect all external power supplies of the system before installing/removing the module. Failure to do so may result in electric shock, module fault, or malfunction.
- Do not use the PLC in environments with dust, greasy smoke, conductive dust, corrosive or combustible gases, exposed to high temperature, condensation, wind & rain, or subject to vibration and shock. Electric shock, fire, and malfunction may also result in damage or deterioration to the product.
- The PLC is open-type equipment that must be installed in a control cabinet with lock (cabinet housing protection > IP20). Only the skilled personnel who have undergone specialized electrical training and possess comprehensive electrical expertise can open the cabinet.





- Prevent metal filings and wire ends from dropping into ventilation holes of the PLC during installation. Failure to comply may result in fire, fault, and malfunction.
- Ensure there are no unwanted matters on ventilation surface. Failure to comply may result in poor ventilation, which may cause fire, fault, or malfunction.
- Ensure the module is connected to the respective connector securely and hook the module firmly. Improper installation may result in malfunction, fault, or fall-off.
- Ensure natural ventilation for the equipment.

Wiring

- Wiring must be carried out by skilled personnel who have undergone specialized electrical training and possess comprehensive electrical expertise.
- Disconnect all external power supplies of the system before wiring. Failure to comply may result in electric shock, module fault, or malfunction.
- After wiring, install the terminal cover attached to the product before power-on or operation. Failure to comply may result in electric shock.
- Insulate the cable terminals properly to ensure the insulation distance between cables will not be shortened after cables are connected to the terminal block. Failure to comply may result in electric shock or damage to the product.



- To avoid electric shock, cut off the power supply before connecting the equipment to the power supply.
- The input power supply of this product must be 24 VDC. Power supplies outside $\pm 20\%$ of 24 VDC can cause severe damage to the product. Therefore, check whether the DC power supply provided by the switching-mode power supply is stable at a regular interval.

Operation and maintenance
<p> CAUTION</p> <ul style="list-style-type: none">• Operation and maintenance must be carried out by skilled personnel who have undergone specialized electrical training and possess comprehensive electrical expertise.• Do not touch the terminals while the power is on. Failure to comply may result in electric shock or malfunction.• Disconnect all external power supplies of the system before cleaning the module or re-tightening screws on the terminal block or the connector. Failure to comply may result in electric shock.• Disconnect all external power supplies of the system before assembling/disassembling the module or connecting/removing the communication cables. Failure to comply may result in electric shock or malfunction.
<p>Safety Recommendations</p> <ul style="list-style-type: none">• In the position where the operator directly touches the machinery part, for example, where a machinery tool is loaded/unloaded, or where a machine runs automatically, the on-site manual operating devices and any other alternative means must be carefully arranged and designed so that they are independent of the PLC and can start or terminate the automatic running of the system.• If modification on the program is needed during system operation, use the lock function or other protective measures. Ensure that only authorized personnel can make the necessary modifications.
Disposal
<p> CAUTION</p> <ul style="list-style-type: none">• Treat the scrapped product as industrial waste. Dispose of the battery according to local laws and regulations.• Recycle retired equipment by observing industry waste disposal standards to avoid environmental pollution.

1.2 Industrial Information Security

The product provides interfaces to connect to the network and transmit data through the network interfaces. In order to protect factories, systems, machines and networks from network attacks and ensure their safe operation, implement appropriate industrial information security protection mechanisms.

The customer is responsible for providing and continuously ensuring a secure connection between the product and the network to prevent unauthorized access to its factories, systems, machines and networks. The system can only be connected to the corporate network or the Internet if it is connected securely and appropriate security measures are in place (for example, using anti-virus software and a firewall).

Inovance continuously develops and improves products and solutions to improve safety. It is strongly recommended that you update the product promptly and always use the latest version.



Tampering with software (such as viruses, Trojans, and Worms) can lead to unsafe drive state, which can put the device in an unsafe operation state. This may result in death, serious injury, and property damage. Observe the following strictly.

- Always use the latest software version. If the product version is no longer supported or the latest version of the program is not applied, customers are at increased risk of cyber-attacks.
 - Take proper protection measures (including but not limited to deploying anti-virus software, firewall, WAF, IPS/IDS, situational awareness system, ID verification, and data encryption) to prevent files in the mobile storage device from being damaged by malware and protect products, networks, systems, and interfaces from unauthorized access, disturbance, intrusion, data disclosure, or information theft.
 - Check all safety-related interfaces and settings after commissioning.
-

2 Product Information

2.1 Model and Nameplate

Model

GL 20 -8 TC
 ① ② ③ ④

<p>① Product Information GL: Inovance general local module</p>	<p>③ Number of Input Channels • 4: 4 input channels • 8: 8 input channels</p>
<p>② Series Number 20: 20 series module</p>	<p>④ Module Type TC: Thermocouple temperature detection</p>

Nameplate

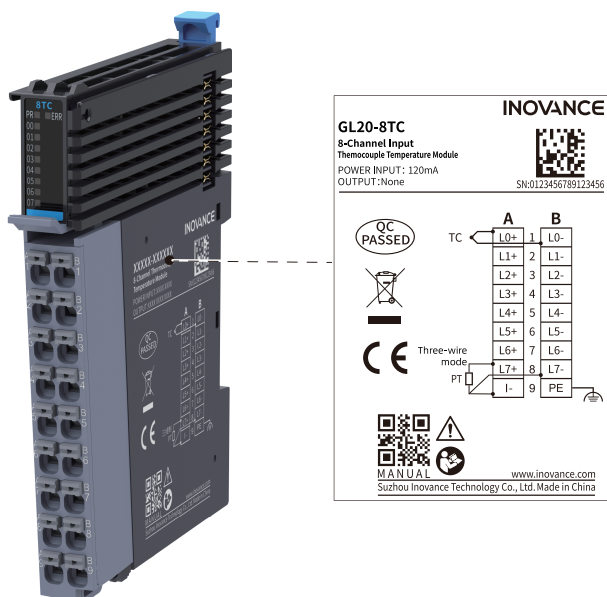





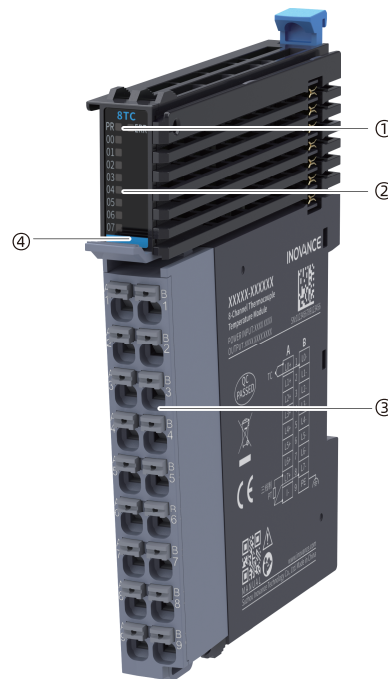

The data for ordering the product is shown in the following table.

Model	Description	Material Code	Applicable Model
GL20-8TC	GL20 series 8-channel thermocouple input temperature detection module	01441245	Applicable to GL20 series communication interface modules, such as GL20-RTU-ECT32

2.2 Components



No.	Component	Description			
①	Signal indicators	PR (POWER +RUN)	Power/Run indicator	Yellow-green	<ul style="list-style-type: none"> • Solid ON: The module is operating normally. • Flashing quickly: The module is addressed successfully. • Flashing slowly: The module is powered on but not addressed. • OFF: The module is not powered on or is faulty.
		ERR	Fault indicator	Red	ON when the module is faulty. For details, see “Troubleshooting” on page 26
②	I/O signal indicator	00 to 07	Channel indicator	Yellow-green	<ul style="list-style-type: none"> • Solid ON: The channel is not faulty. • OFF: The channel encounters faults such as disabling, overlimit, disconnection, overflow, and underflow.
③	I/O terminals	Eight thermocouple inputs, as defined in “4.2 Terminal Definition” on page 16			
④	Color identification		Red: Digital output		Orange: Analog output
			Gray: Digital input		Green: Analog input
			White: Communication		Blue: Other modules

Note

- Flashing quickly: The indicator is on for 200 ms and off for 200 ms.
- Flashing slowly: The indicator is on for 200 ms and off for 1 s.

2.3 Technical Specifications

General specifications

Item	Specification
IP rating	IP20
Dimensions (W x H x D)	12 mm x 100 mm x 75 mm
Weight	About 62 g

Power supply specifications

Item	Specification
Rated voltage of bus input power supply	5 VDC (4.75 VDC to 5.25 VDC)
Rated current of bus input power supply	110 mA (typical value@5 V)
Hot swap	Not supported

Input specifications

Item	Specification
Number of input channels	8
Digital resolution	24-bit resolution
Display sensitivity	0.1, 0.01, or 0.001 (depending on the number of decimal places). The unit is °C or °F.
Input type	Thermocouple input. Supported thermocouple types include B, E, N, J, K (default), R, S, T, C and ±100 mV.
Compensation method	Supports internal and external cold junction compensation. To apply the external cold junction compensation, the 7th channel of the module shall adopt the PT100 three-wire connection. <ul style="list-style-type: none"> External cold junctions: For normal wiring, the value of the external cold junction is displayed. For abnormal wiring (including two-wire connection), the maximum value of 3276.7 is displayed. When overlimit/sensor disconnection/overflow detection is enabled, the corresponding fault code will be reported. Internal cold junctions: No difference with other channels
Accuracy (at normal temperature: 25°C)	(±0.1%) ^[1] (±100mV full scale) + cold junction compensation error ^[2]
Accuracy (at operating temperature: -20°C to +55°C)	(±0.3%) ^[1] (±100mV full scale) + cold junction compensation error ^[2]
Isolation	Isolated between I/O terminals and power supply, as well as between channels and MCU. Not isolated between channels.
Input indicator	/
Input derating	/
Overflow and open circuit detection	Supported
Power consumption	< 0.6 W
Anti-interference capacity ^[3]	For default parameter settings, the anti-interference capacity is 50 dB in differential mode and 120 dB in common mode.

Note

- [1]: Indicates ADC sampling accuracy, which needs to be determined based on sensor type and thermocouple detection temperature range. For details, see [“7.1 Appendix 1: Accuracy Calculation” on page 28](#).
- [2]: The cold junction compensation error needs to be determined based on the compensation type, installation direction, adjacent module type and operating temperature range. For details, see [“7.1 Appendix 1: Accuracy Calculation” on page 28](#).
- [3]: The anti-interference capacity is strongly associated with sampling cycle and filter time. The anti-interference capacity is only about 25 dB when the filter time is set to 0, and sampling cycle to 100ms. The sensor must be equipped with shielded cables for use by the customer.

Software specifications

Item	Specification
Input PDO data volume	Max. 32 bytes
Diagnostic report function configuration	Supported
Diagnostic detection enable configuration	Overflow and offline detection supported
Filter time	0s to 16s (configurable through software, default is 5s)
Overflow and underflow detection	Overflow and underflow faults are reported only when the overflow detection function is enabled.
Overflow detection configuration	Supported
Independent channel configuration	Supported
Temperature offset configuration	Supported
Temperature configuration range	-204.8 to +204.7
Display mode	Centigrade degree (°C), Fahrenheit degree (°F)
Sampling cycle	100ms, 500 ms, 1000 ms, 2000 ms for 8 channels
Warm-up time	45 min
Sampling refresh	Refresh asynchronously according to the sampling cycle, with no need to refresh synchronously according to the bus cycle
Stop mode	Output based on the maximum value with no further refresh
Open circuit or overflow/underflow detection	Output based on the maximum value with no further refresh
Channel diagnosis	Beyond upper limit alarm, beyond lower limit alarm, open circuit alarm, overflow error
Software diagnostics	Not supported
Configuration diagnosis	Configuration fault identification, channel parameter configuration fault

2.4 Environmental Specifications

Item	Specification
Installation/Operating environment	Free from conductive dust, conductive fibers, explosive dust, flammable gases, water mist/greasy dirt, corrosive dusts/gases, strong vibration, and repetitive shock
Max. altitude	≤ 2000 m
Pollution degree	2
Immunity	2 kV on power supply cable (compliant with IEC 61000-4-4)
Overvoltage category	I
EMC immunity level	Zone B, IEC61131-2
ESD protection level	Contact discharge +/-6 kV, air discharge +/-8 kV

Product Information

Item	Specification
Vibration resistance	<ul style="list-style-type: none"> • Application scenario: Tested according to IEC60068-2-6; 3.5 mm amplitude at 5 Hz to 8.4 Hz; 1 g acceleration at 8.4 Hz to 200 Hz; in ten cycles/axes • Transportation scenario: Tested according to IEC60068-2-64, 0.01 g²/Hz power spectral density at 5 Hz to 100 Hz; 0.001 g²/Hz power spectral density at 200 Hz; 1.14 g Grms
Shock resistance	Application/Transportation scenario: Tested according to IEC60068-2-27; 15 g peak gravitational acceleration; 11ms pulse width; 18 times in X/Y/Z-axis directions
Operating temperature/ humidity	<ul style="list-style-type: none"> • Temperature: -20°C to +55°C • Humidity: < 95% RH (30°C), without condensation
Storage temperature/ humidity	<ul style="list-style-type: none"> • Temperature: -20°C to +60°C • Humidity: < 95% RH (30°C), without condensation
Transportation temperature/humidity	<ul style="list-style-type: none"> • Temperature: -40°C to +70°C • Humidity: < 95% RH (40°C), without condensation

3 Mechanical Installation

3.1 Installation Precautions

- Make sure the module is powered off before installing or removing.
- Do not hot swap the modules. Otherwise, the modules may be damaged by overcurrent or overvoltage, and the communication interface module or PLC may be subject to restart, user data loss or corruption.
- Do not drop or shock the housing or terminals of the module to avoid damage.

3.2 Installation Dimensions

Module

The installation dimensions (in mm) are shown in the figure below.

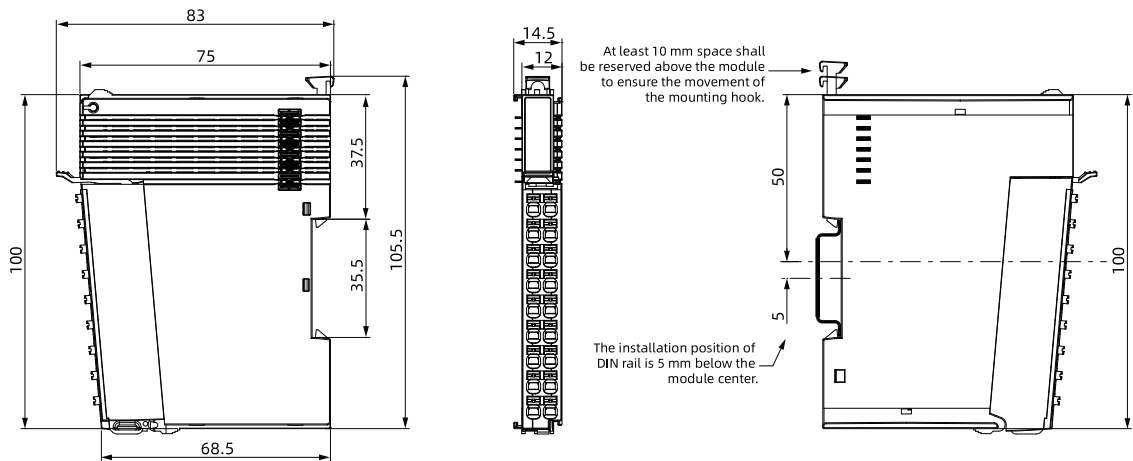

Cable

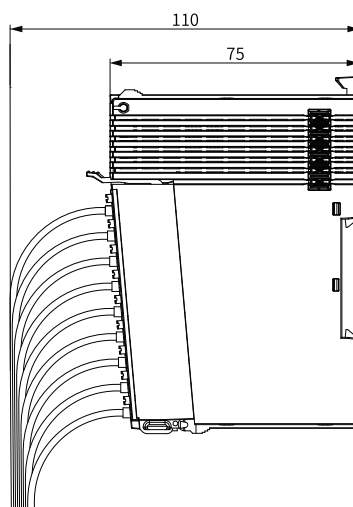

3.3 Installation Method

The module is mounted onto a DIN rail in conformity with IEC 60715 (width: 35 mm, thickness: 1 mm). The dimensions (unit: mm) are shown below.

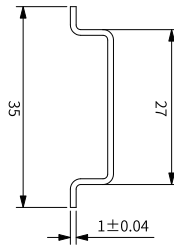

Caution

When installed on a DIN rail other than the recommended one (especially the one whose thickness is not 1.0 mm), the product will not fit in place as the mounting hook does not work.

Installing modules side by side

Install modules side by side by sliding them along the top and bottom guide rails of adjacent modules.

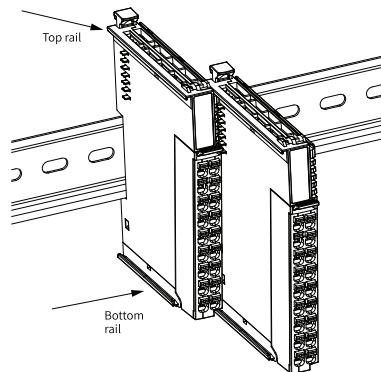

Installing modules onto DIN Rail

1. Align the module with the DIN rail and push the module in the direction indicated by the arrow until you hear a click, as shown below.

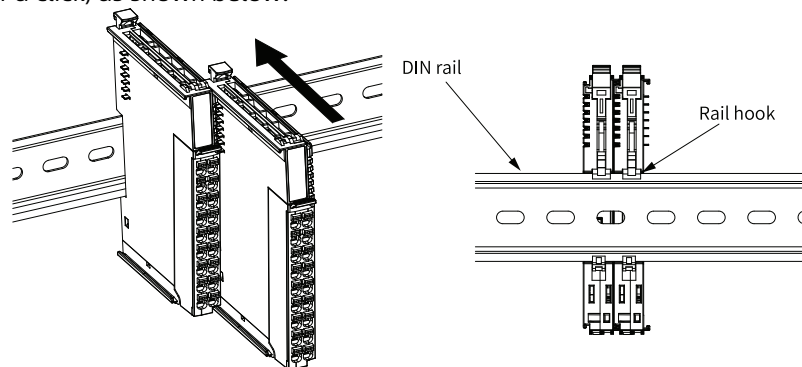

2. Make sure the DIN rail mounting hook of the module is locked. The locked and unlocked states of the mounting hook are shown below.

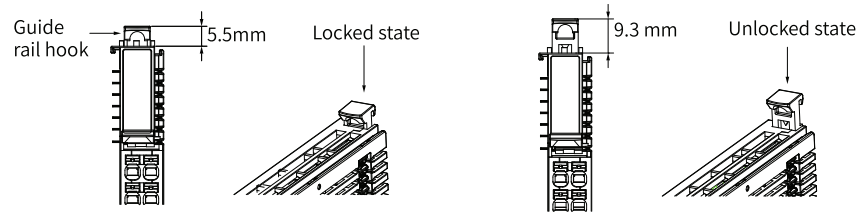

- If the mounting hook is pressed down, it is locked.
- If the mounting hook is lifted up, it is unlocked.

To lock the module to the DIN rail, press down the mounting hook.



Caution

When the module is not installed on the DIN rail, keep the rail hook in locked state. A hook that kept in unlocked state for a long period of time may fail to function properly.

3. Install a DIN rail end plate on both sides of the PLC or the module.

To install the end plate, hook the bottom of it to the bottom of the DIN rail, rotate the end plate to hook the top of it to the top of the DIN rail, and then tighten the screw to lock the end plate in place,

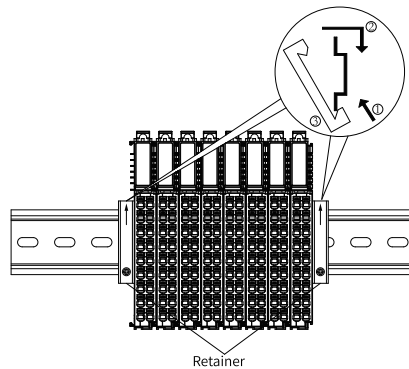
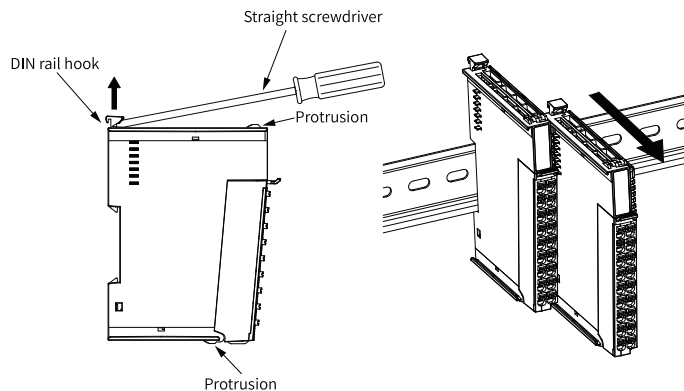

Figure 3-1 Installing end plate

Removing modules

Pry the DIN rail mounting hook upwards with a tool such as a slotted screwdriver, hold the protrusions and pull the module out straight forward. Then, press down the top of the mounting hook.



4 Electrical Installation

4.1 Cable Selection

The cable lug and cable diameter included in the following table are only for reference.

Material Name	Applicable Cable Diameter		KST		Suzhou Yuanli	
	mm ²	AWG	Model	Crimping Tool	Model	Crimping Tool
Tubular lug	0.3	22	E0308	KST2000L	0308	YAC-5
	0.5	20	E0508			
	0.75	18	E7508			
	1.0	18	E1008			
	1.5	16	E1508			

To use other types of tubular lugs, crimp the lug to the cables according to the shape and dimension requirements shown below.

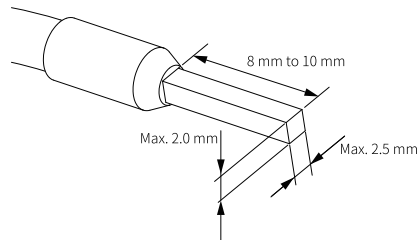

4.2 Terminal Definition

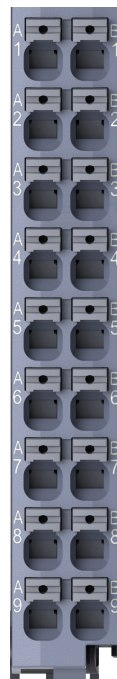

Left Signal Description	Left Signal	Left Terminal	Right Terminal	Right Signal	Right Signal Description
Channel 0 thermocouple input (+)	L0+	A1	B1	L0-	Channel 0 thermocouple input (-)
Channel 1 thermocouple input (+)	L1+	A2	B2	L1-	Channel 1 thermocouple input (-)
Channel 2 thermocouple input (+)	L2+	A3	B3	L2-	Channel 2 thermocouple input (-)
Channel 3 thermocouple input (+)	L3+	A4	B4	L3-	Channel 3 thermocouple input (-)
Channel 4 thermocouple input (+)	L4+	A5	B5	L4-	Channel 4 thermocouple input (-)
Channel 5 thermocouple input (+)	L5+	A6	B6	L5-	Channel 5 thermocouple input (-)
Channel 6 thermocouple input (+)	L6+	A7	B7	L6-	Channel 6 thermocouple input (-)
Channel 7 thermocouple input (+)	L7+	A8	B8	L7-	Channel 7 thermocouple input (-)
Input B for the external PT cold junction compensation (three-wire mode)	I-	A9	B9	PE	Grounding

4.3 Terminal Wiring

Wiring precautions

- Do not bundle the expansion cable together with power cables (with high voltage and large current) that produce strong interference signals; otherwise, the expansion cable may be influenced by noise, surge, or induction. Separate it from other cables and avoid cabling in parallel.
- Use recommended cables and adapter boards for connection. It is recommended that shielded cables be used as expansion cables to enhance anti-interference capacity.
- Apply single-point grounding for the shielding of shielded cable and solder sealed cable.

Circuit block diagram and wiring diagram

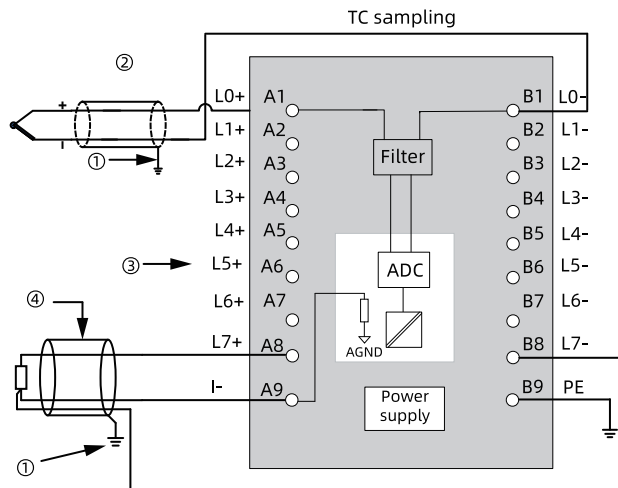

Name	Description
①	Use shielded compensating cables and connect the shield to PE. It is recommended to connect the PE terminal of the module to the external PE.
②	Compensating cables are required to extend thermocouples; otherwise, temperature measurements may be abnormal.
③	8-channel TC wiring: The wiring methods for A2 and B2 to A7 and B7 are the same as those for A1 and B1.
④	1-channel three-wire PT wiring (for external cold junction compensation): Terminals A8, B8, and A9 are connected. Use a cable with three low-resistance wires that have no difference in resistance.

5 Program Commissioning

The following is an example where AM600 is used as the master control module along with the GL20-8TC module in InoProShop.

1. Enable the AM600 series PLC as the EtherCAT master and add the GL20-RTU-ECT32 communication interface module.

- a. In the left **Devices** pane, double-click **Network Configuration** and click the AM600 figure in the upper left corner of the interface. Check the "EtherCAT Master" to enable the PLC as an EtherCAT master.

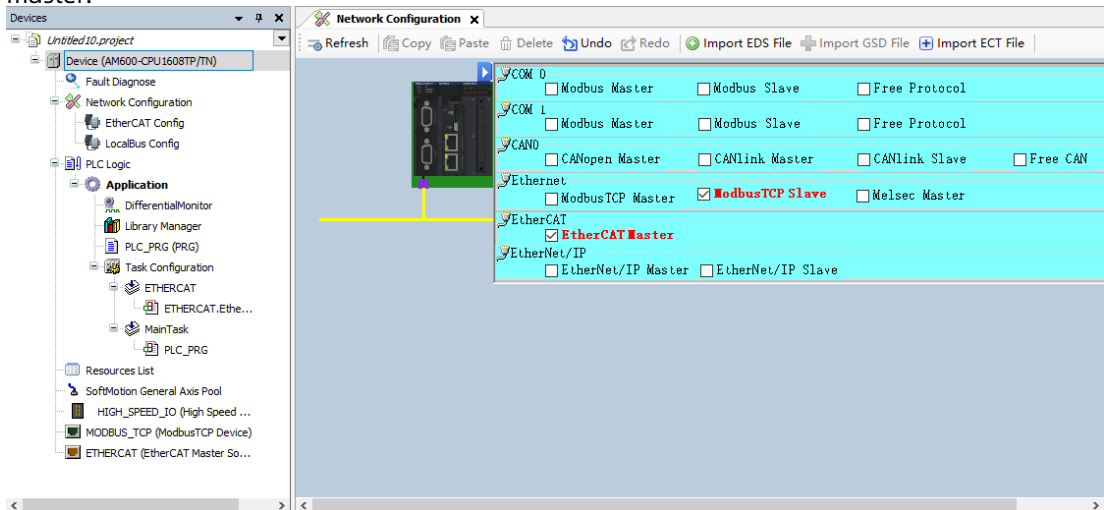

- b. Add the GL20-RTU-ECT32 communication interface module.

- Method 1: In the right **Network Devices List**, double-click "GL20-RTU-ECT32" to add the module.

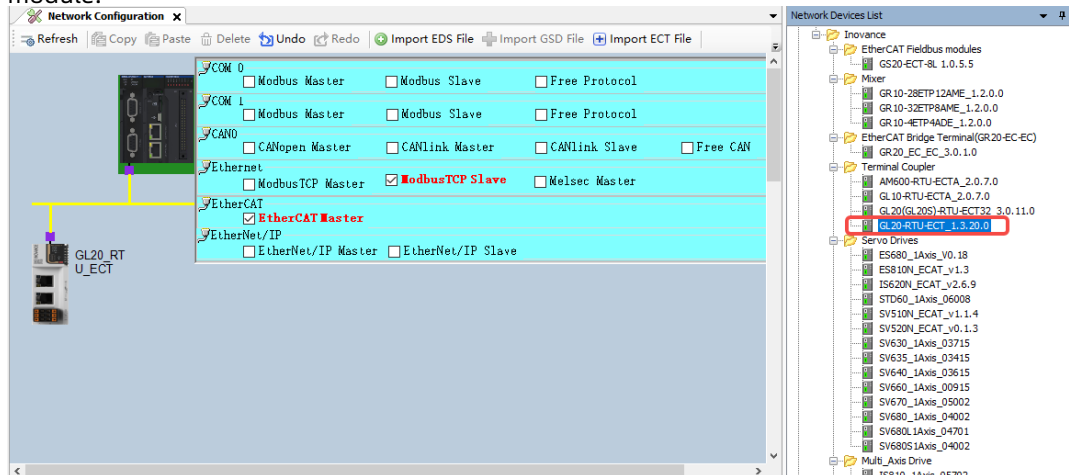

- Method 2: In the left **Devices** pane, right-click **ETHERCAT(EtherCAT Master SoftMotion)** and select **Add Device**. Select "GL20_RTU_ECT32_X.X.X.X" in the pop-up dialog box and click **Add Device**.

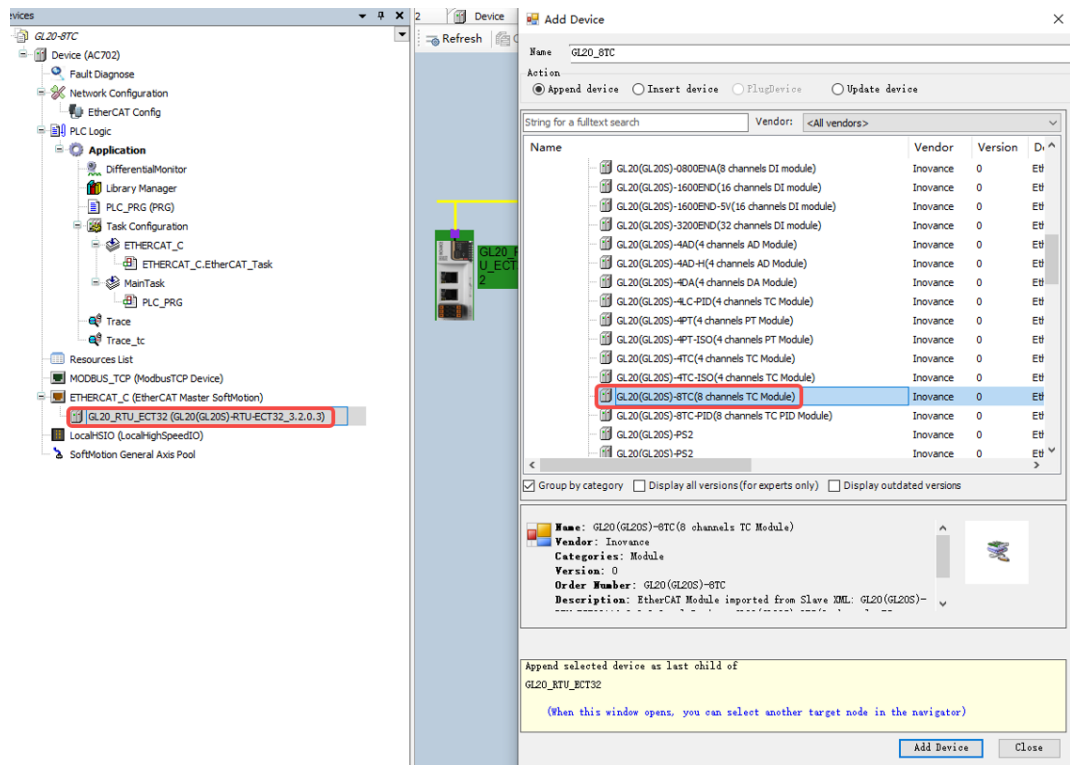

- Method 3: In the left **Devices** pane, right-click **ETHERCAT(EtherCAT Master SoftMotion)** and select **Scan For Devices**. Click **Scan Devices**, select the GL20-RTU-ECT32 module, and click **Copy Scan Device**.

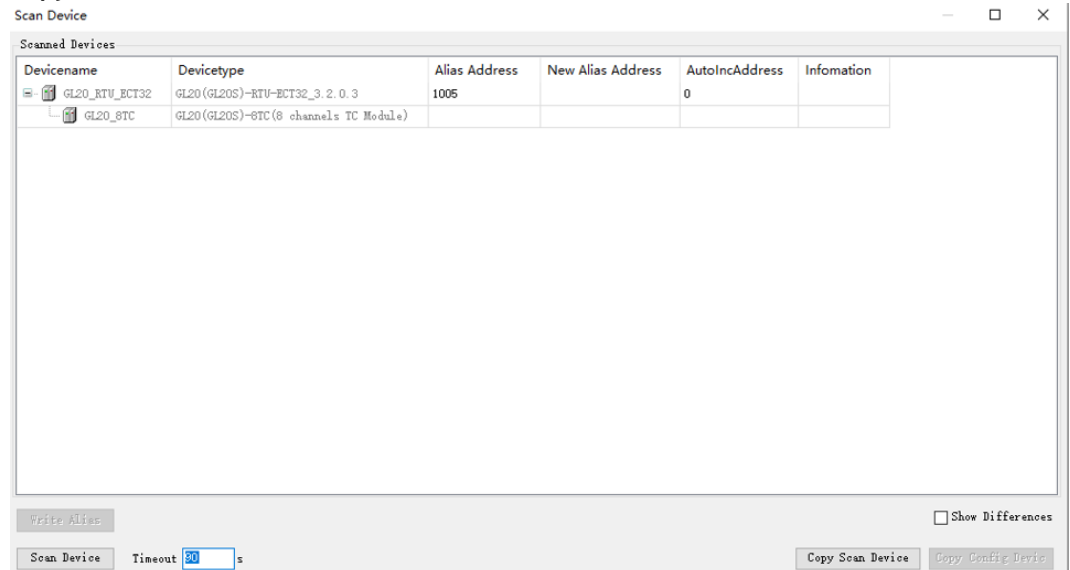

2. Add the GL20-8TC module.

- Method 1: Open the **Hardware Configuration** pane by double-clicking **EtherCAT Config** in the left **Devices** pane, or double-clicking the GL20-RTU-ECT32 figure in the **Network Configuration** pane. In the right **In\Output Module List**, double-click "GL20-8TC" or drag and place it after the GL20-RTU-ECT32 module.

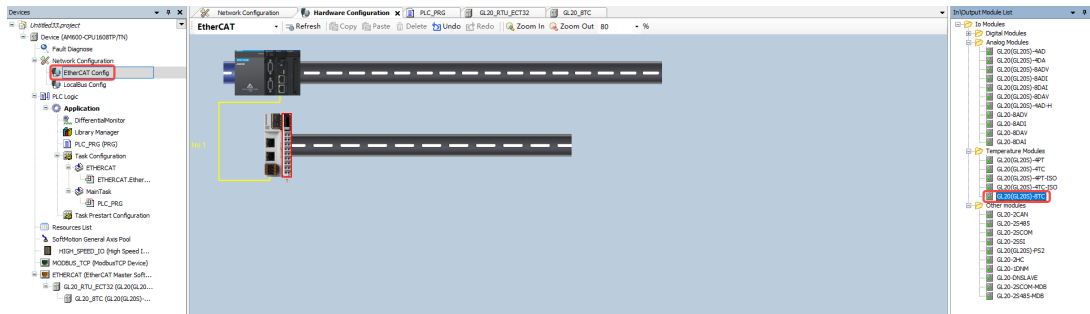

- Method 2: In the left **Devices** pane, right click "GL20_RTU_ECT32" and select **Add Device**. Select "GL20-8TC" in the pop-up dialog box and click **Add Device**.

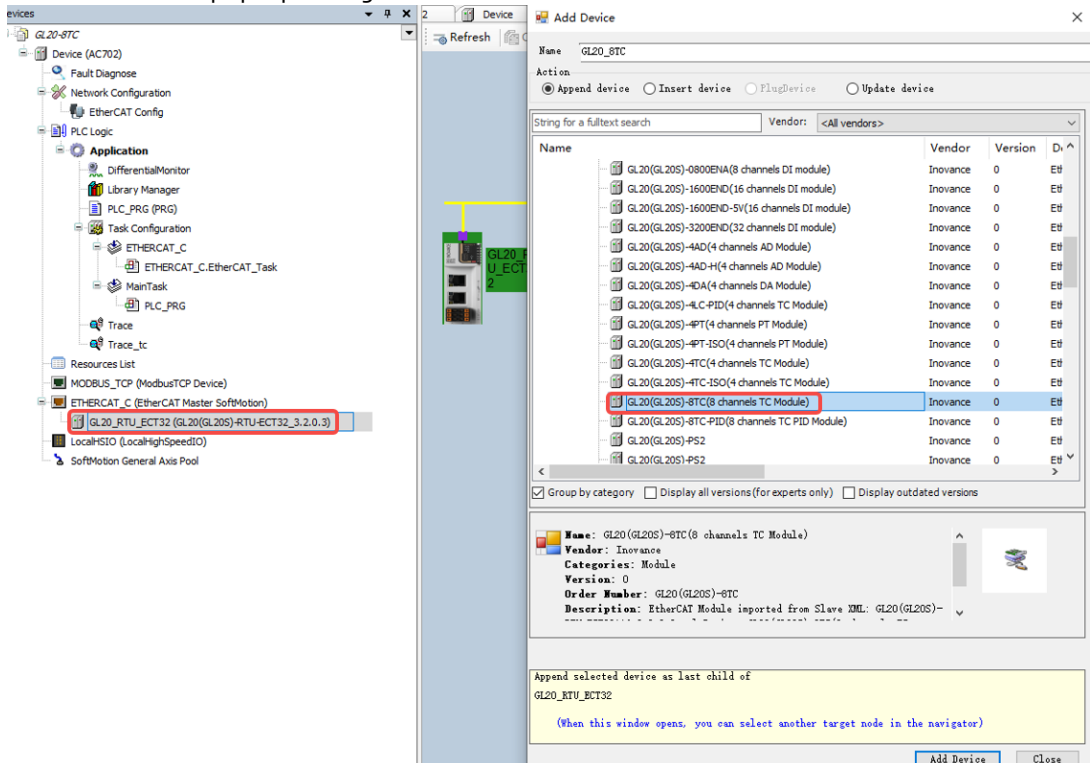

- Method 3: In the left **Devices** pane, right-click **ETHERCAT(EtherCAT Master SoftMotion)** and select **Scan For Devices**. Click **Scan Devices**, select the GL20-8TC module, and click **Copy Scan Device**.

3. Double-click the GL20-8TC module in the left **Devices** pane to set the **Generic Configuration**.

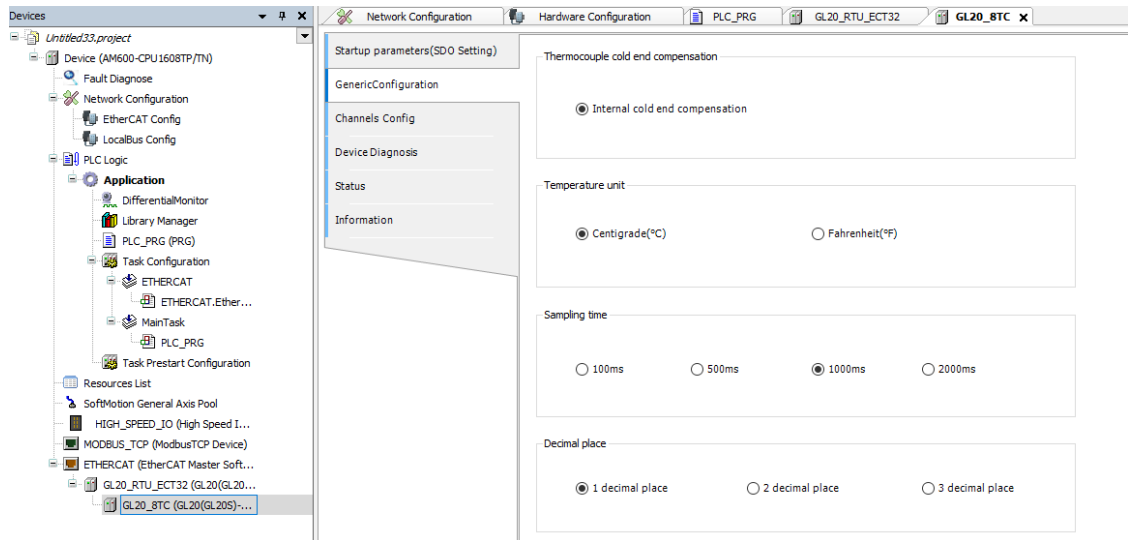

The following table introduces the internal cold junction compensation parameters.

Parameter	Description	Configuration
Cold junction compensation of thermocouple	Cold junction compensation method of thermocouple sensors	Supports internal (default) and external cold junction compensation. For external cold junction compensation, the 7th channel of the module shall be connected to a PT100 thermal resistance for cold junction compensation and cannot be used for sampling.
Temperature unit	The unit of temperature data collected by the module	Supported temperature units (by default is Centigrade degree): <ul style="list-style-type: none"> • Centigrade degree (°C) • Fahrenheit degree (°F)
Sampling cycle	Sampling and polling time of temperature data for the 8-channel module	Supported sampling cycles: <ul style="list-style-type: none"> • 100ms • 500ms • 1000ms (default value) • 2000 ms
Decimal places	Temperature sampling accuracy	Supported decimal places: <ul style="list-style-type: none"> • One decimal place (default) • Two decimal places • Three decimal places

4. Double-click the GL20-8TC module to set the **Channels Config**.

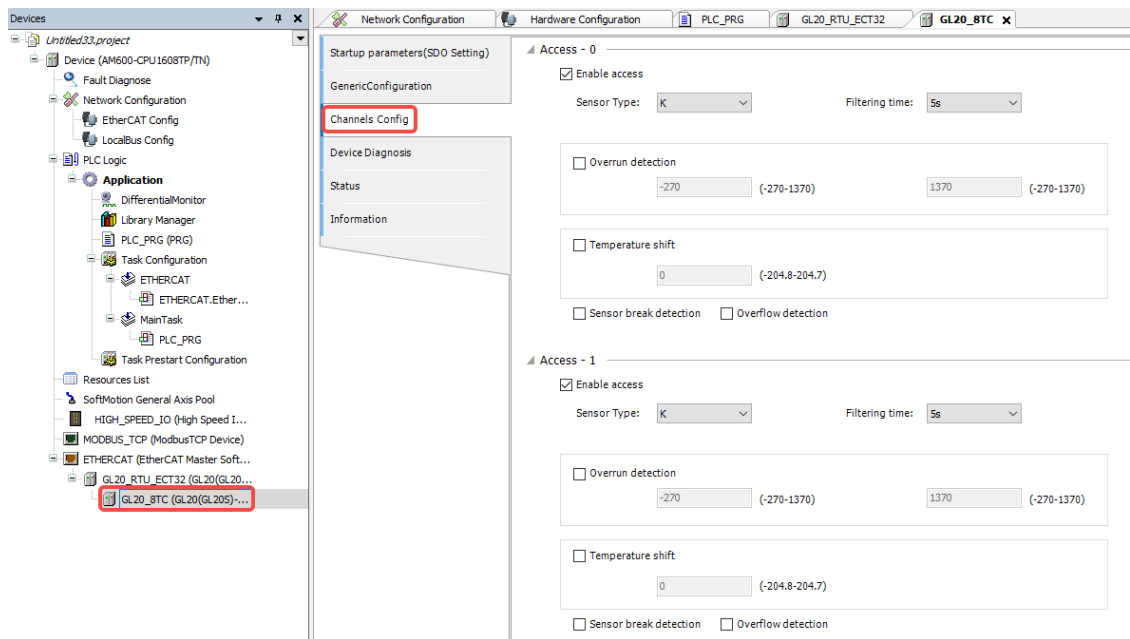

The parameters for channel configuration are shown in the following table.

Parameter	Description	Configuration
Enable access	Whether to enable the channel	Checked by default <ul style="list-style-type: none"> • Check to enable the channel • Uncheck to disable the channel
Sensor Type	Type of sensor connected to the module channel	Supported thermocouple types: K (default), J, E, B, N, S, T, C, and ± 100 mV
Filter time	Sampling filter time for module analog channels	0s to 16s, with the default of 5s
Overflow detect	Whether to detect the channel data overflow	Unchecked by default <ul style="list-style-type: none"> • Check to enable overflow detection • Uncheck to disable overflow detection
Lower Value (°C)	Lower limit of channel data	Depends on sensor models
Upper Value (°C)	Upper limit of channel data	Depends on sensor models
Enable offset	Whether to enable the channel data offset	Unchecked by default <ul style="list-style-type: none"> • Check to enable temperature offset • Uncheck to disable temperature offset
Offset value (°C)	Offset value of channel data	-204.8 to +204.7, with the default of 0
Sensor offline detect	Whether to enable the open circuit detection of the channel	Unchecked by default <ul style="list-style-type: none"> • Check to enable sensor open circuit detection • Uncheck to disable sensor open circuit detection
Up and down overflow detection	Whether to detect overflow and underflow of the channel data	Unchecked by default <ul style="list-style-type: none"> • Check to enable overflow/underflow detection • Uncheck to disable overflow detection

5. Create new variables.

- a. In the left **Devices** pane, double-click **PLC_PRG** and click  in the upper right corner to switch to table mode.

Program Commissioning

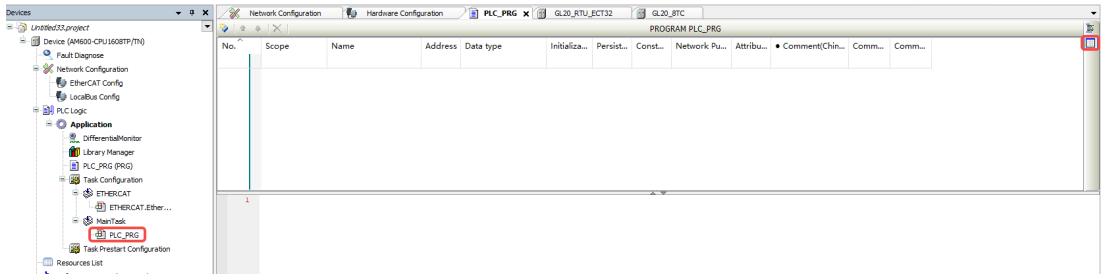

b. Add custom input variables "GL20_8TC_CH0", "GL20_8TC_CH1", "GL20_8TC_CH2", "GL20_8TC_CH3", "GL20_8TC_CH4", "GL20_8TC_CH5", "GL20_8TC_CH6", and "GL20_8TC_CH7". Set the scope of these variables to "VAR" and data type to "REAL", as shown below.

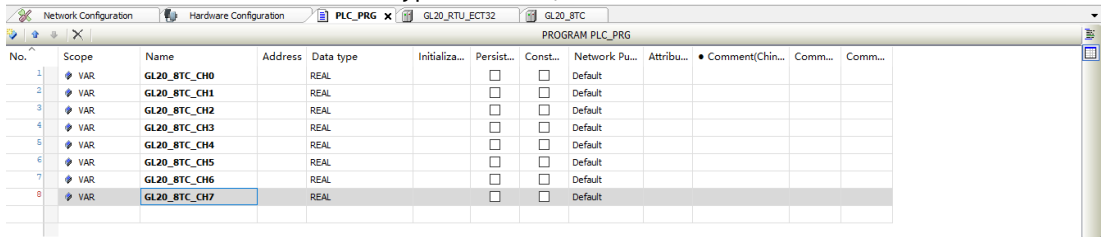

6. Map variables to the corresponding input channels.

a. In the left **Devices** pane, double-click **GL20_RTU_ECT32** and click the **EtherCAT I/O Mapping** tab.

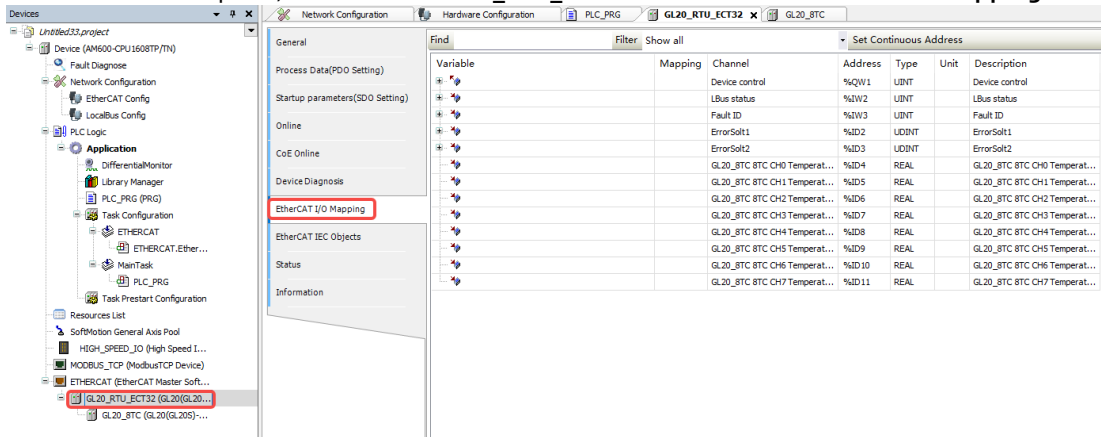

b. On the **EtherCAT I/O Mapping** tab, double-click a variable entry and click  to open the **Input Assistant** dialog box. Choose **Application > PLC_PRG > specific variables** and click **OK** .

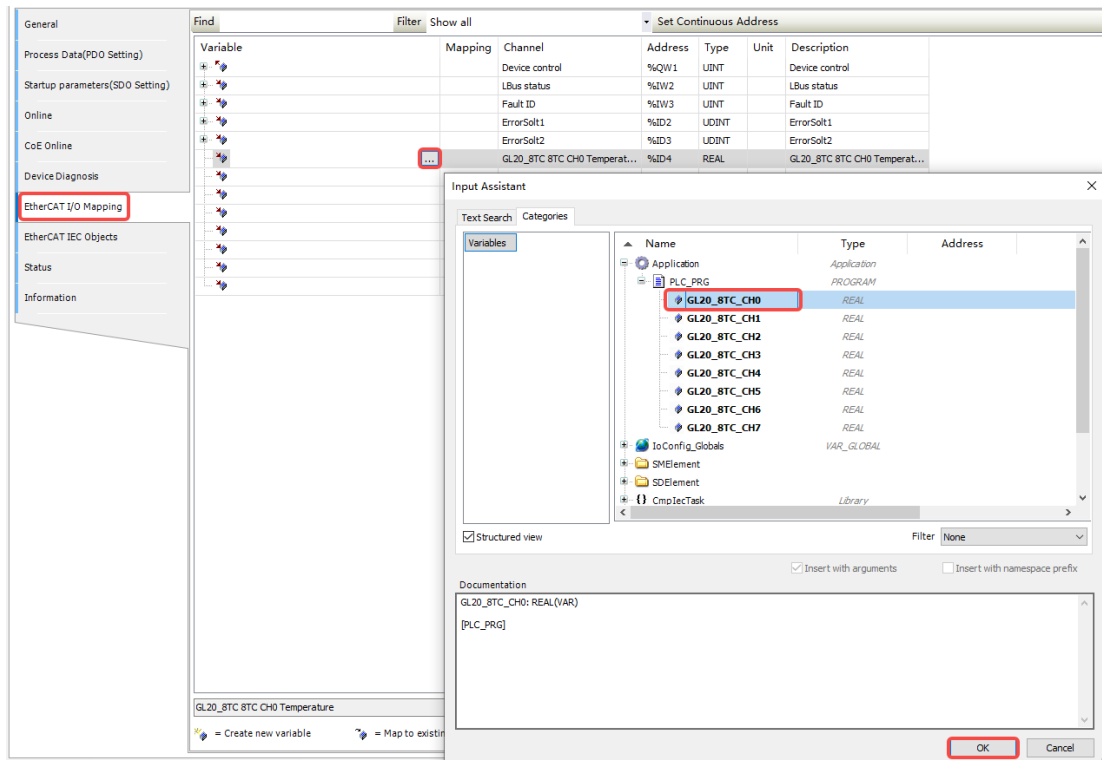



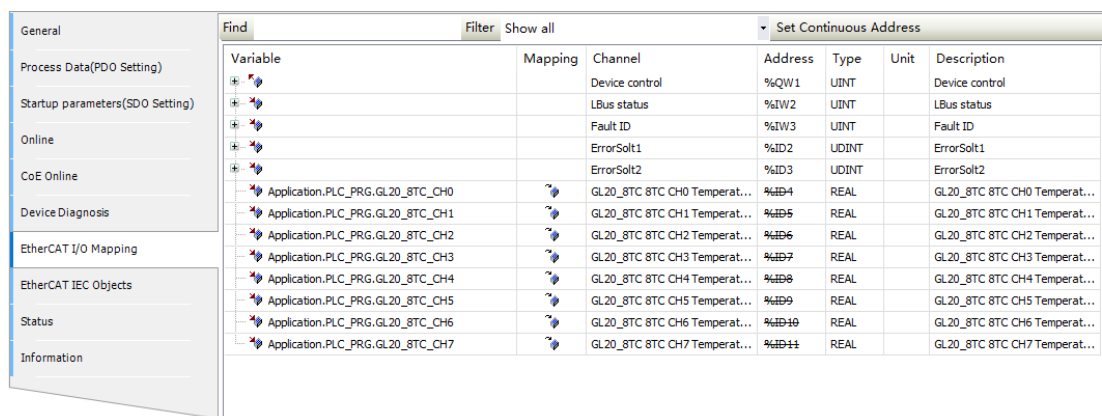

In the **EtherCAT I/O Mapping** tab, map the input variables "GL20_8TC_CH0", "GL20_8TC_CH1", "GL20_8TC_CH2", "GL20_8TC_CH3", "GL20_8TC_CH4", "GL20_8TC_CH5", "GL20_8TC_CH6", and "GL20_8TC_CH7" to the input channels of the configured module, as shown in the figure below.



7. Double-click **PLC_PRG** in the left **Devices** pane and complete the programming on the **PLC_PRG** page.

8. Check, compile, log in, download, and run the program.

- Click  on the toolbar at the top of the interface to check whether the program is correct.
- Click  on the toolbar to compile all the code into PLC executable code.
- Click  on the toolbar, and follow the interface prompts to log in to the PLC and download the program.
- Click  on the toolbar to execute the program.

6 Troubleshooting

When the ERR indicator is ON, it indicates that the module is faulty. The module reports a fault code, which can be obtained through the diagnostic data object dictionary value in the **CoE Online** interface, as shown below.

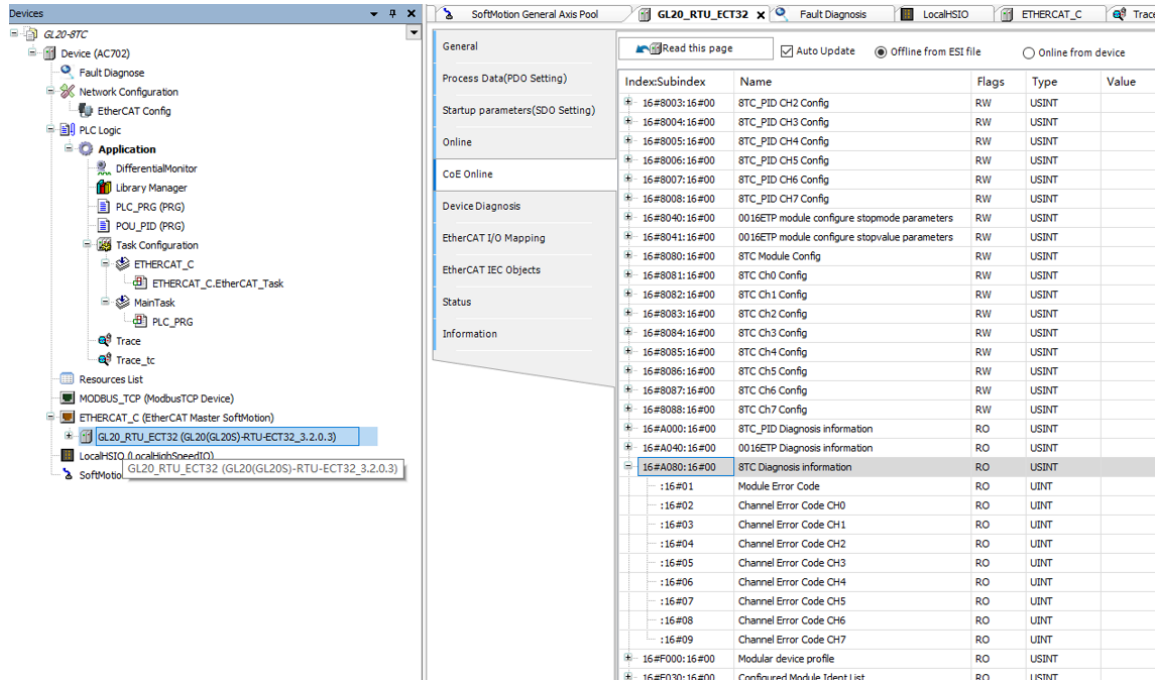

For the module in slot n ($n = 0$ to 62), the object dictionary definition for index $0xA000+0x40*n$ is shown in the table below.

Index	0xA000+0x40*n: 8TC Diag data				
Subindex	Name	Data Type	Access Type	Mapping	Default Value
0	Subindex 000	USINT	RO	NO	9
1	Module Error Code	UINT	RO	NO	0x0000
2	Channel Error Code CH0	UINT	RO	NO	0x0000
3	Channel Error Code CH1	UINT	RO	NO	0x0000
4	Channel Error Code CH2	UINT	RO	NO	0x0000
5	Channel Error Code CH3	UINT	RO	NO	0x0000
6	Channel Error Code CH4	UINT	RO	NO	0x0000
7	Channel Error Code CH5	UINT	RO	NO	0x0000
8	Channel Error Code CH6	UINT	RO	NO	0x0000
9	Channel Error Code CH7	UINT	RO	NO	0x0000

Note

The thermocouple input supports fault detection for the module and channels.

The channel fault codes are defined as follows:

Fault Code	Description	Solution
0x6001	Channel open-circuited	Check the wiring of the sensor.
0x6002	Channel short-circuited	/
0x6003	Channel data exceeds the upper limit.	Check whether the sensors, wiring, or configured limit ranges are appropriate.
0x6004	Channel data exceeds the lower limit.	Check whether the sensors, wiring, or configured limit ranges are appropriate.
0x6005	Overflow	Check whether the selected sensor range is exceeded.
0x6006	Underflow	Check whether the selected sensor range is undershot.

7 Appendix

7.1 Appendix 1: Accuracy Calculation

Within the operating temperature range, when the temperature change rate is less than 0.3°C/min, it is necessary to wait 45 minutes before measuring. The accuracy of this product is shown below.

- Internal cold junction measurement accuracy = ADC sampling accuracy + Internal cold junction compensation error (irrelevant to the installation method)
 - It is recommended to install the module horizontally in upright position (refer to [“3.3 Installation Method” on page 14](#)) and use it adjacent to temperature modules within the operating temperature range. In this case, the cold junction compensation error is within ±3°C.
 - It is not recommended to use the module adjacent to modules that consume more than 3.5W power, such as GL20-3232ETN module.

The following table shows the internal cold junction compensation error.

Installation Direction	Adjacent Module Type	Cold Junction Compensation Error (-20°C to 0°C)	Cold Junction Compensation Error (0°C to 55°C)
Horizontal, upright	Temperature module	±3°C	±1.75°C
	Non-temperature module	±6.5°C	±4.5°C
Non-horizontal, upright	Temperature module	±5.5°C	±4°C
	Non-temperature module	±5.5°C	±4.5°C

The module is equipped with four built-in temperature sensors for internal cold junction compensation.

- External cold junction measurement accuracy = ADC sampling accuracy + External cold junction compensation error (±1°C) + Sensor error (irrelevant to the installation method)

The external cold junction measurement principle is shown below. The module requires a 45-minute warm-up after power-on before measurement.

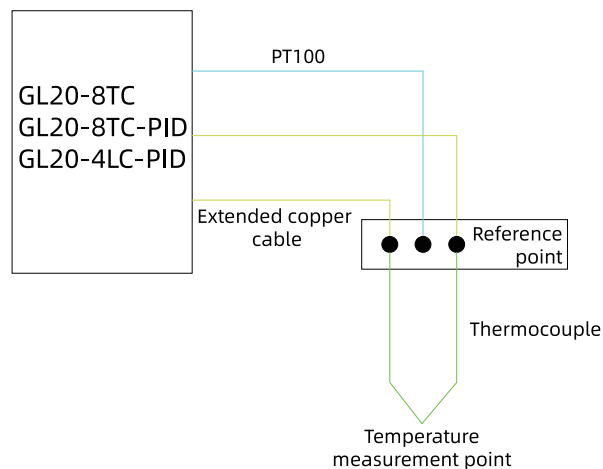

The following table shows the thermocouple detection range and ADC sampling accuracy.

Sensor type	Detection range	ADC Sampling Accuracy
B	200.0°C to 1800.0°C, 392.0°F to 3272.0°F	$\geq \pm 5^\circ\text{C}@200^\circ\text{C} \leq T \leq 400^\circ\text{C}$ $< \pm 5^\circ\text{C}@400^\circ\text{C} \leq T \leq 750^\circ\text{C}$ $< \pm 3^\circ\text{C}@750^\circ\text{C} \leq T \leq 1200^\circ\text{C}$ $< \pm 3.5^\circ\text{C}@1200^\circ\text{C} \leq T \leq 1800^\circ\text{C}$
E	-270.0°C to +1000.0°C, -454.0°F to +1832.0°F	$\geq \pm 1^\circ\text{C}@-270^\circ\text{C} \leq T \leq -200^\circ\text{C}$ $< \pm 1^\circ\text{C}@-200^\circ\text{C} \leq T \leq 400^\circ\text{C}$ $< \pm 1.5^\circ\text{C}@400^\circ\text{C} \leq T \leq 1000^\circ\text{C}$
N	-200.0°C to +1300.0°C, -328.0°F to +2372.0°F	$< \pm 2^\circ\text{C}@-200^\circ\text{C} \leq T \leq -150^\circ\text{C}$ $< \pm 1.5^\circ\text{C}@-150^\circ\text{C} \leq T \leq 750^\circ\text{C}$ $< \pm 0.2\%$ of displayed value $@750^\circ\text{C} \leq T \leq 1300^\circ\text{C}$
J	-210.0°C to +1200.0°C, -346.0°F to +2192.0°F	$\geq \pm 1^\circ\text{C}@-210^\circ\text{C} \leq T \leq -100^\circ\text{C}$ $< \pm 1^\circ\text{C}@-100^\circ\text{C} \leq T \leq 500^\circ\text{C}$ $< \pm 0.2\%$ of displayed value $@500^\circ\text{C} \leq T \leq 1200^\circ\text{C}$
K	-270.0°C to +1370.0°C, -454.0°F to +2498.0°F	$\geq \pm 1.5^\circ\text{C}@-270^\circ\text{C} \leq T \leq -200^\circ\text{C}$ $< \pm 1.5^\circ\text{C}@-200^\circ\text{C} \leq T \leq -100^\circ\text{C}$ $< \pm 1^\circ\text{C}@-100^\circ\text{C} \leq T \leq 500^\circ\text{C}$ $< \pm 0.2\%$ of displayed value $@500^\circ\text{C} \leq T \leq 1300^\circ\text{C}$ $\geq \pm 2.6^\circ\text{C}@1300^\circ\text{C} \leq T \leq 1370^\circ\text{C}$
R	-50.0°C to +1765.0°C, -58.0°F to +3209.0°F	$\geq \pm 4^\circ\text{C}@-50^\circ\text{C} \leq T \leq 0^\circ\text{C}$ $< \pm 4^\circ\text{C}@0^\circ\text{C} \leq T \leq 250^\circ\text{C}$ $< \pm 2^\circ\text{C}@250^\circ\text{C} \leq T \leq 500^\circ\text{C}$ $< \pm 3.5^\circ\text{C}@500^\circ\text{C} \leq T \leq 1700^\circ\text{C}$ $\geq \pm 3.5^\circ\text{C}@1700^\circ\text{C} \leq T \leq 1765^\circ\text{C}$
S	-50.0°C to +1765.0°C, -58.0°F to +3209.0°F	$\geq \pm 4^\circ\text{C}@-50^\circ\text{C} \leq T \leq 0^\circ\text{C}$ $< \pm 4^\circ\text{C}@0^\circ\text{C} \leq T \leq 250^\circ\text{C}$ $< \pm 2^\circ\text{C}@250^\circ\text{C} \leq T \leq 500^\circ\text{C}$ $< \pm 3.5^\circ\text{C}@500^\circ\text{C} \leq T \leq 1700^\circ\text{C}$ $\geq \pm 3.5^\circ\text{C}@1700^\circ\text{C} \leq T \leq 1768^\circ\text{C}$
T	-270.0°C to +400.0°C, -454.0°F to +752.0°F	$\geq \pm 1^\circ\text{C}@-270^\circ\text{C} \leq T \leq -200^\circ\text{C}$ $< \pm 1^\circ\text{C}@-200^\circ\text{C} \leq T \leq 400^\circ\text{C}$
C	0°C to 2300°C, 32°F to +3276.7°F	$\leq \pm 3^\circ\text{C}@0^\circ\text{C} \leq T < 300^\circ\text{C}$ $\leq \pm 4^\circ\text{C}@300^\circ\text{C} \leq T < 700^\circ\text{C}$ $\leq \pm 5.75^\circ\text{C}@700^\circ\text{C} \leq T < 2300^\circ\text{C}$

7.2 Appendix 2: Object Dictionary Definition

Introduction

The GL20-8TC module is used for thermocouple temperature collection. It is equipped with 8 independent channels for simultaneous temperature collection. The configuration of each channel is independent from each other.

- Name: 8TC Module
- Module category: Temperature Measure
- Module identification code: 0x10F41052

Input data

For the module in slot n (n = 0 to 62) and channel m (m = 0 to 3), the object dictionary definition for index 0x7000+0x40*n+m is shown in the table below.

Index	0x7000+0x40*n+m:			
Subindex	Name	Data Type	Access Type	Mapping
0	Subindex 000	USINT	RO	NO
1	CHm Temperature	REAL	RO	YES

The parameters for channel configuration are shown in the following table.

Parameter	Description
Temperature	Feedback temperature

Configuration Data

For the module in slot n (n = 0 to 62), the object dictionary definition for index 0x8000+0x40*n is shown in the table below.

Index	0x8000+0x40*n: SampleTime/Unit/Float/CoolJunction				
Subindex	Parameter	Data Type	Access Type	Mapping	Default Value
0	Subindex 000	USINT	RO	NO	1
1	SampleTime/ Unit/Float/ CoolJunction	UINT	RW	NO	162

The parameters for channel configuration are shown in the following table.

Parameter	Description	Value Range	Unit
SampleTime/Unit/Float/ CoolJunction	Sampling cycle + Temperature unit + Decimal place + Cold junction compensation	Sampling cycle: Bit 0 to Bit 2 • 0: 100ms • 1: 500ms • 2: 1000ms • 3: 2000ms Temperature unit: Bit 3 to Bit 4 • 0: Celsius degree • 1: Fahrenheit degree Decimal places: Bit 5 to Bit 6 • 1: 1 decimal place • 2: 2 decimal places • 3: 3 decimal places Cold junction compensation of thermocouple: Bit 7 • 0: External cold junction compensation • 1: Internal cold junction compensation	-

For the module in slot n (n = 0 to 62), the object dictionary definition for index 0x8001+0x40*n is shown in the table below.

Index	0x8001+0x40*n: 8TC MODE					
Subindex	Name	Data Length	Data Type	Access Type	Mapping	Default Value
0	Subindex 000	1	USINT	RO	NO	0xF
1	Ch0 SampleMode + SenserType + ChannelEnable	1	USINT	RW	NO	131
2	Ch0 Filter	1	USINT	RW	NO	5
3	Ch0 Detect	1	USINT	RW	NO	0
4	Ch0 Reserve	1	USINT	RW	-	-
5	Ch0 Bias	2	INT	RW	NO	0
6	Ch0 UpLimit	2	INT	RW	NO	13700
7	Ch0 DownLimit	2	INT	RW	NO	-2700

The parameters for channel configuration are shown in the following table.

Index	Name	Description	Value Range	Default Value	Unit
0x8001: 1	SampleMode + SenserType + ChannelEnable	Sampling mode + Sensor type + Channel enabling	Bit 0 to Bit 1: Sampling mode Thermocouple sampling Default: 3 Bit 2 to Bit 6: Sensor type Default is K type. .0: K .1: J .2: E .3: B .4: N .5: R .6: S .7: T .8: C .9: ±100 mv Bit 7: Channel enabling .0: Disabled .1: Enabled	131	-
0x8001: 2	Filter	Channel filter parameter	0s to 16s, with the default of 5s	5	s

Index	Name	Description	Value Range	Default Value	Unit
0x8001: 3	Detect	Temperature detection and diagnostic parameters	Bit 0: Temperature offset • 0: Disabled • 1: Enabled (normal) Bit 1: Wire disconnection detection • 0: Disabled • 1: Enabled Bit 2: Overlimit detection • 0: Disabled • 1: Enabled Bit 3: Overflow/underflow detection • 0: Disabled • 1: Enabled Bit 4 to Bit 6: Reserved Bit 7: Default is 0. Value 1 is for test tooling only, used to block the cold junction temperature. In normal conditions, there is no need to configure this bit.	4	-
0x8001: 4	Reserve	-	-	0	-
0x8001: 5	Bias	Channel temperature offset parameter	-204.8 to +204.7, with the default of 0	0	-
0x8001: 6	UpLimit	Upper limit of channel temperature	The range of "UpLimit" equals to the temperature setting range of the current sensor type, with the default being the maximum value of the temperature setting range in the current mode.	13700	-
0x8001: 7	DownLimit	Lower limit of channel temperature	The range of "DownLimit" equals to the temperature setting range of the current sensor type, with the default being the minimum value of the temperature setting range in the current mode.	-2700	-

7.3 Appendix 3: Version Matching Information

The version matching information is shown in the following table.

Product Name	Firmware Version	Device Description File (.xml)	InoProShop Version
This module	Board software: 1.1.8.0 and later Logic software: 4.0.0.0 and later	-	V1.9.1 and later
GL20-RTU-ECT32 series communication interface module	Board software: 3.1.16.0 and later Logic software: 0.1.4.5 and later	3.2.0.3 and later	

Note

You can get the firmware of the module and the firmware of communication interface module from Inovance technical support, and download XML files and InoProShop from <https://www.inovance.com>.

Service and Support

Should you encounter a safety accident during the use or operation of the product, or face challenges in operating and maintaining the equipment, which remain unresolved after the relevant documentation is consulted, we provide multiple channels to ensure prompt resolution:

- Channel #1: Contact service@inovance.com.
- Channel #2: Visit <https://www.inovance.com/global> to access document downloads, after-sales support, spare parts ordering, repair applications, and authenticity verification services.
- Channel #3: Download My Inovance app (<https://zshc-eu.inovance.com/download-pc/>) where you can access products info and documentation, and query product parameters.

We are committed to providing you with quick and professional technical support, and we look forward to your satisfaction and trust.



Copyright © Shenzhen Inovance Technology Co., Ltd.

PS00019553A00

Shenzhen Inovance Technology Co., Ltd.

www.inovance.com

Suzhou Inovance Technology Co., Ltd.

www.inovance.com

Add.: Inovance Headquarters Tower, High-tech Industrial Park,
Guanlan Street, Longhua New District,
Shenzhen 518000, P.R. China

Tel: (0755) 2979 9595

Fax: (0755) 2961 9897

Add.: No. 52, Tian E Dang Road, Wuzhong District, 215104,
Suzhou City, Jiangsu Province, P.R. China

Tel: (0512) 6637 6666

Fax: (0512) 6285 6720