

PS00008916A02

GL20-2SSI 2-Channel Encoder Input Module User Guide

Suzhou Inovance Technology Co., Ltd.

Add.: No.52, Tian E Dang Road, Wuzhong District,
Suzhou 215104, P.R. China

Tel: (0512) 6637 6666 Fax: (0512) 6285 6720

www.inovance.com



Preface

■ Introduction

The GL20-2SSI series 2-channel encoder input module can be used with GL20 series communication interface module such as GL20-RTU-ECT.

This guide introduces the product information, mechanical installation, electrical installation, commissioning, and troubleshooting of the product.

■ Standard

The following table lists the certifications, directives, and standards that the product may comply with. For details about the acquired certificates, see the certification marks on the product nameplate.

Certification	Directive		Standard
CE Certification	EMC Directive	2014/30/EU	24 VDC products: EN 61131-2 220 VAC products: EN 61131-2 EN 61000-3-2 EN 61000-3-3
	LVD Directive	2014/35/EU	EN 61010-1 EN 61010-2-201
	RoHS Directive	2011/65/EU amended by (EU) 2015/863	EN IEC 63000
UL/cUL Certification	-		UL 61010-1 UL 61010-2-201 CAN/CSA-C22.2 No. 61010-1 CSA C22.2 NO. 61010-2-201
KCC Certification	-		-
EAC certification	-		-

Certification	Directive		Standard
UKCA Certification	Safety Regulations	Electrical Equipment (Safety) Regulations 2016	EN 61010-1 EN 61010-2-201
	EMC Regulations	Electromagnetic Compatibility Regulations 2016	24 VDC products: EN 61131-2 220 VAC products: EN 61131-2 EN 61000-3-2 EN 61000-3-3
	RoHS Regulations	Directive (RoHS) Regulations 2012	EN IEC 63000

More Documents

Document Name	Document Coding	Description
GL20-RTU-ECT Communication Interface Module User Guide	PS00004985	This guide describes the installation, wiring and more of the product.
GL20-RTU-PN Communication Interface Module User Guide	PS00007594	This guide describes the installation, wiring and more of the product.

Revision History

Revision date	Version	Description
March 2025	A02	Updated "3.3 Terminal Wiring" on page 23 .
November 2023	A01	Optimized the Caution content in "4.1 Overview" on page 25 .
July 2023	A00	Initial release.

Access to the Guide

This guide is not delivered with the product. You can obtain the PDF version by the following methods:

- Do keyword search under Service and Support at www.inovance.com.
- Scan the QR code on the product with your smart phone.
- Scan the QR code below to install My Inovance app, where you can search for and download user guides.



■ Warranty Disclaimer

Inovance provides warranty service within the warranty period (as specified in your order) for any fault or damage that is not caused by improper operation of the user. Maintenance will be charged after the warranty expires.

Within the warranty period, maintenance will be charged for the following damage:

- Damage caused by operations not following the instructions in the user guide
- Damage caused by fire, flood, or unusual voltage
- Damage caused by unintended use of the product
- Damage caused by use beyond the specified scope of application of the product
- Damage or secondary damage caused by force majeure (natural disaster, earthquake, and lightning strike)

The maintenance is charged according to the latest Price List of Inovance. If otherwise agreed upon, the terms and conditions in the agreement shall prevail.

For details, see the Product Warranty Card.

Fundamental Safety Instructions

■ Safety Disclaimer

1. Read and comply with the safety instructions during installation, operation, and maintenance of the equipment.
2. To ensure your safety and prevent damage to the equipment, follow the marks on the equipment and all the safety instructions in this guide.
3. "CAUTION", "WARNING", and "DANGER" items in the guide do not indicate all safety precautions that need to be followed; instead, they just supplement the safety precautions.
4. Use this equipment according to the designated environment requirements; otherwise, a fault may occur. Malfunction or damage caused by improper use is not covered by warranty.
5. Inovance shall take no responsibility for any personal injury or property damage caused by improper use.

■ Safety Levels and Definitions



"DANGER" indicates that failure to comply with the notice can result in severe personal injury or even death.



"WARNING" indicates that failure to comply with the notice may result in severe personal injury or even death.



"CAUTION" indicates that failure to comply with the notice may result in minor or moderate personal injury or equipment damage. Keep this guide properly for future use and deliver it to the end user.

Control System Design



- Provide a safety circuit outside the PLC so that the control system can still work safely once external power failure or PLC fault occurs.
- Add a fuse or circuit breaker because the module may smoke or catch fire due to long-time overcurrent caused by operation above rated current or load short-circuit.



- An emergency stop circuit, a protection circuit, a forward/reverse operation interlocked circuit, and an upper position limit and lower position limit interlocked circuit must be set in the external circuits of PLC to prevent damage to the equipment.
- To ensure safe operation, for the output signals that may cause critical accidents, use external protection circuits and safety mechanism.
- Once the CPU of the PLC detects an exception in the system, all outputs may be closed; however, when a fault occurs in the controller circuit, the output may not be under control. Therefore, it is necessary to design an appropriate external control circuit to ensure normal operation.
- If the PLC output units such as relays or transistors are damaged, the output may fail to switch between ON and OFF states according to the commands.
- The PLC is designed to be used in an indoor electrical environment (overvoltage category II). The power supply must have a system-level surge protector, assuring that overvoltage due to lightning shock cannot be applied to the PLC's power supply input terminals, signal input terminals and output terminals, preventing damage to the equipment.

Installation



- Installation must be carried out by skilled personnel who have undergone specialized electrical training and possess comprehensive electrical expertise.
- Disconnect all external power supplies of the system before removing/installing the module. Failure to do so may result in electric shock, module fault or malfunction.
- Do not use the PLC in environments with dust, greasy smoke, conductive dust, corrosive or combustible gases, exposed to high temperature, condensation, wind & rain, or subject to vibration and shock. Electric shock, fire and malfunction may also result in damage or deterioration to the equipment.
- The controller is open-type equipment that must be installed in a control cabinet with lock (IP rating of the control cabinet enclosure > IP20). Only qualified professionals can open the cabinet.



- Prevent metal filings and wire ends from dropping into ventilation holes of the PLC during installation. Failure to comply may result in fire, fault and malfunction.
- Ensure there are no foreign matters on ventilation surface. Failure to comply may result in poor ventilation, which may cause fire, fault and malfunction.
- Ensure the module is connected to the respective connector securely and hook the module firmly. Improper installation may result in malfunction, fault or fall-off.

Wiring



- Wiring must be carried out by skilled personnel who have undergone specialized electrical training and possess comprehensive electrical expertise.
- Disconnect all external power supplies of the system before wiring. Failure to comply may result in electric shock, module fault or malfunction.
- Insulate the cable terminals properly to ensure the insulation distance between cables will not be shortened after cables are connected to the terminal block. Failure to comply may result in electric shock or damage to the equipment.



- To avoid electric shock, cut off the power supply before connecting the equipment to the power supply.
- The input power of the product must meet the specifications listed in this guide. If the power input does not meet the specifications, the equipment may be damaged. Thus, check regularly that the DC power provided by the switching-mode power supply unit is stable.

Operation and Maintenance



- Operation and maintenance must be carried out by skilled personnel who have undergone specialized electrical training and possess comprehensive electrical expertise.
- Do not touch the terminals while the power is on. Failure to comply may result in electric shock or malfunction.
- Disconnect all external power supplies of the system before cleaning the module. Failure to comply may result in electric shock.
- Disconnect all external power supplies of the system before assembling/disassembling the module or connecting/removing the communication cables. Failure to comply may result in electric shock or malfunction.

Safety Recommendations

- In the position where the operator directly touches the machinery part, for example, where a machinery tool is loaded/unloaded, or where a machine runs automatically, the on-site manual operating devices and any other alternative means must be carefully arranged and designed so that they are independent of the programmable controller and can start or terminate the automatic running of the system.
- If you need to modify the program while the system is running, use the lock function or other protective measures. Ensure that only authorized personnel can make the necessary modifications.

Disposal



- Treat the scrapped equipment as industrial waste. Dispose of the battery according to local laws and regulations.
- Recycle retired equipment by observing industry waste disposal standards to avoid environmental pollution.

1 Product Information

1.1 Overview

The GL20-2SSI 2-channel encoder input module is located between the SSI absolute encoder and the controller, and serves to process the periodically sampled encoder values in the controller.

It has the following features:

- Supports the standardization of SSI absolute encoder data frames (i.e. SSI data frames).
- Supports inversion mode to adjust the motion direction of the SSI absolute encoder to the rotation direction of the motion axis.
- Supports the settings of SSI absolute encoder encoding type (Gray code/binary code).
- Supports flexible settings of SSI absolute encoder bits to accommodate more types of SSI absolute encoders (10-bit to 32-bit).
- Supports parity check.
- Supports a wider range of SSI absolute encoder baud rate settings (0.1 MHz to 2 MHz).
- Supports flexible settings of monostable trigger time (interval time between adjacent frames).
- Supports multi-sampling mode (activated only when the frame interval is 512 μ s or 1024 μ s).

1.2 Naming Rules and Nameplate

GL 20 - 2 SSI

① ② ③ ④

① Product Information GL: Inovance general local module	③ Number of Channels 2: Two channels
② Series Number 20: 20 series module	④ Module Type SSI: Encoder input module

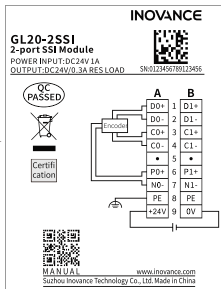
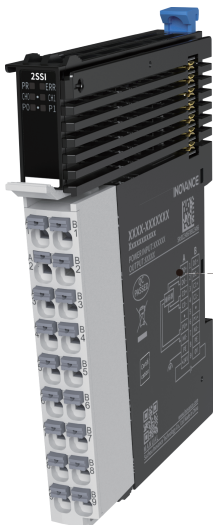





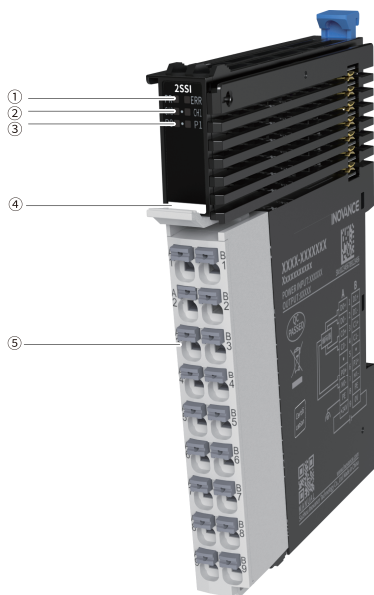

The data for ordering the product is shown below.

Model	Description	Product Code	Applicable Model
GL20-2SSI	GL20 series 2-channel encoder input module	01440445	GL20 communication interface module

1.3 Components



No.	Name	Description			
①	Signal indicator	PR (POWER +RUN)	Power/Run indicator	Yellow-green	<ul style="list-style-type: none"> ● Steady ON: Module in normal operation ● Quick flashing: Module addressed successfully ● Slow flashing: Module powered on but not addressed ● OFF: Module not powered on or abnormal
		ERR	Error indicator	Red	Module error
②	Encoder indicator	CH0/CH1	SSI0/SSI1 indicator	Yellow-green	<ul style="list-style-type: none"> ● ON: Encoder active ● OFF: Encoder inactive
③	Power indicator	P0/P1	SSI0/SSI1 24V power indicator	Yellow-green	<ul style="list-style-type: none"> ● ON: 24V power active ● OFF: 24V power inactive
④	Color identification		Red: Digital output		Orange: Analog output
			Gray: Digital input		Green: Analog input
			White: Communication		Blue: Other module
⑤	I/O terminal	See detailed definition in "3.2 Terminal Definition" on page 22.			

Note

- Quick flashing: The indicator is on for 200 ms and off for 50 ms, repeating this cycle.
- Slow flashing: The indicator is on for 200 ms and off for 1 s, repeating this cycle.

1.4 Technical Specifications

■ General Specifications

Item	Specification
IP rating	IP20
Dimensions (W x H x D)	12 mm x 100 mm x 75 mm
Weight (g)	Approx. 61 g

■ Power supply specifications

Item	Specification
Rated current of bus input power supply	115 mA
Rated voltage of terminal input power supply	24 VDC (20.4 VDC to 28.8 VDC)
Rated current of terminal input power supply	1 A
Hot swap	Not supported
Anti-reverse connection 24 V	Supported
Output channels of terminal power supply	2 channels
Rated voltage of terminal output power supply	24 VDC (20.4 VDC to 28.8 VDC)
Rated current of terminal output power supply	300 mA per channel
Terminal output power supply protection	<ul style="list-style-type: none">• Over-current protection: When short-circuit or over-current occurs, the internal circuit will self-lock for protection.• Short-circuit diagnosis: After short circuit protection, the circuit sends a low-level signal to the microcontroller to indicate entering the protection state.• Protection unlock: When the circuit is self-locked, the microcontroller needs to send an unlocking signal to control the power supply to resume power supply.

Item	Specification
Isolation from the input power supply	Not supported
Isolation between two power supplies	Not supported

■ Interface specifications

Item	Specification
Number of channels	2 channels
Interface type	SSI
Channel interface signal	<ul style="list-style-type: none"> • SSI output: 2, clock output (C+, C-) • SSI input: 2, data input (D+, D-)
SSI signal voltage	5 V
Output voltage	2 x 24 V
Baud rate and transmission distance	100 kHz - 200 m 200 kHz - 120 m 300 kHz - 100 m 400 kHz - 80 m 500 kHz - 60 m 1 MHz - 25 m 1.25 MHz - 20 m 1.5 MHz - 15 m 2 MHz - 10 m Default: 500 kHz - 60 m
Termination resistor	120 Ω termination resistor provided at the receiving end of the SSI data signal inside the module
Isolation mode	Digital isolation from internal logic signals
Diagnostic report configuration	Supported
Independent channel configuration	Supported (24 V short-circuit diagnosis, communication fault diagnosis, data frame error diagnosis)
Action taken upon encoder disconnection	Encoder output value set to 0

Item	Specification
Signal type	Binary/Gray code Default: Gray code
Data type	Adjustable length: 10 bits to 32 bits Default: 25 bits
Inversion sign	ON/OFF
Parity Check	None/Odd check/Even check

1.5 Environmental Specifications

Item	Specification
Installation/ application environment	Free from conductive dust, conductive fibers, explosive dust, flammable gases, water mist/greasy dirt, corrosive dusts/gases, strong vibration, and repetitive shock
Altitude	≤ 2,000 m
Pollution degree	2
Immunity	2 kV on power supply cable (compliant with IEC 61000-4-4)
Overvoltage category	I
EMC immunity level	Zone B, IEC61131-2
Anti-static rating	Contact discharge +/-6 kV and air discharge +/-8 kV
Vibration resistance	<ul style="list-style-type: none"> ● Application scenario: Tested according to IEC60068-2-6, 3.5 mm amplitude from 5 Hz to 8.4 Hz; 1 g acceleration from 8.4 Hz to 200 Hz; 10 cycles per axial direction ● Transportation scenario: Tested according to IEC60068-2-64, 0.01 g²/Hz power spectral density from 5 Hz to 100 Hz; 0.001 g²/Hz power spectral density at 200 Hz; 1.14 g Grms
Shock resistance	Application/Transportation scenario: Tested according to IEC60068-2-27; 15 g peak acceleration, 11 ms pulse width, 18 cycles in total in X, Y and Z axial directions
Operating temperature/humidity	<ul style="list-style-type: none"> ● Temperature: -20°C to +55°C ● Humidity: < 95% RH (30°C), without condensation

Item	Specification
Storage temperature/ humidity	<ul style="list-style-type: none">● Temperature: -20°C to +60°C● Humidity: < 95% RH (30°C), without condensation
Transportation temperature/humidity	<ul style="list-style-type: none">● Temperature: -40°C to +70°C● Humidity: < 95% RH (40°C), without condensation

2 Mechanical Installation

2.1 Installation Precautions

- Before installing or removing the module, ensure that the module is powered off.
- Do not hot swap the modules. Otherwise, the modules may be damaged by overcurrent or overvoltage, and the communication interface module or PLC may be subject to restart, user data loss, or corruption.
- Prevent the enclosure or terminals of the module from dropping or being impacted to avoid damage to the module.

2.2 Installation Dimensions

■ Module

The installation dimensions (in mm) are shown in the figure below.

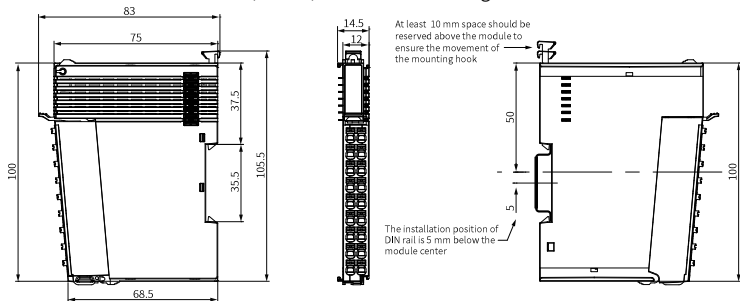

■ Cable connection

The cable dimensions (in mm) are shown in the figure below.

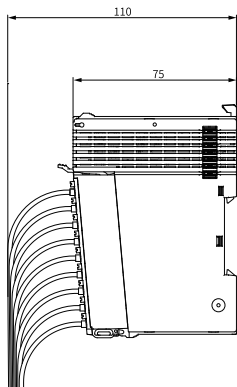

2.3 Installation Method

■ Installing the modules to each other

The module is mounted onto a DIN rail in conformity with IEC 60715 (width: 35 mm, thickness: 1 mm). The dimensions (in mm) are shown below.

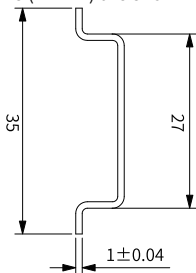

Caution

When installed on a DIN rail other than the recommended one (especially the one whose thickness is not 1.0 mm), the product will not fit in place as the mounting hook does not work.

Install the modules to each other through top and bottom guide rails, as shown below.

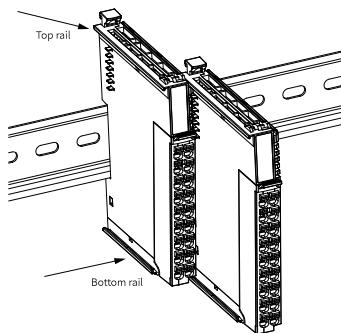

■ Installing the module onto DIN rail

1. Align the module with the DIN rail and push it in the direction indicated by the arrow until you hear a click. See the following figure.

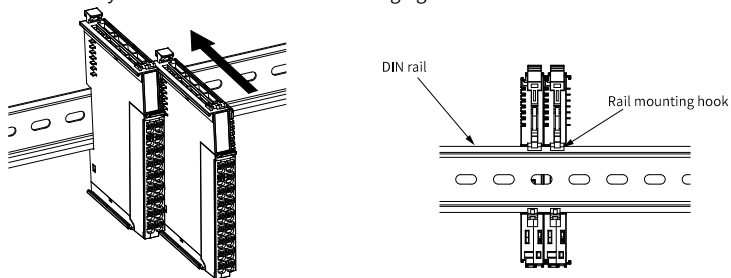

2. Make sure the DIN rail mounting hook of the module is locked. The locked and unlocked states of the mounting hook are shown below.

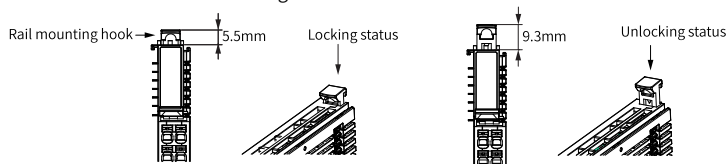

- If the mounting hook is pressed down, it is locked.
- If the mounting hook is lifted up, it is unlocked.

To lock the PLC to the DIN rail, press down the mounting hook.



When the module is not installed on the rail, keep the mounting hook in the locked state. Keeping the mounting hook unlocked for a prolonged time may cause the hook to fail.

3. Mount a DIN rail end plate on both sides of the PLC or the module.

To install the end plate, hook the bottom of it to the bottom of the DIN rail, rotate the end plate to hook the top of it to the top of the DIN rail, and then tighten the screw to lock the end plate in place.

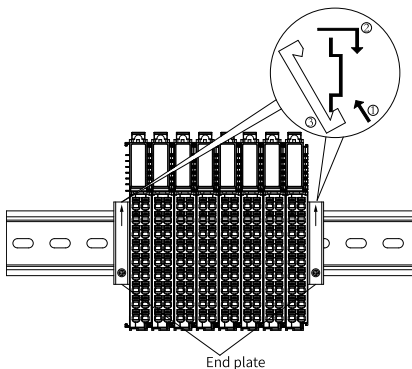

■ Removal

Pry the DIN rail mounting hook upwards with a tool such as a slotted screwdriver, hold the protrusions and pull the module out straight forward. Then, press down the top of the mounting hook.

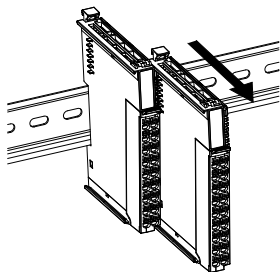
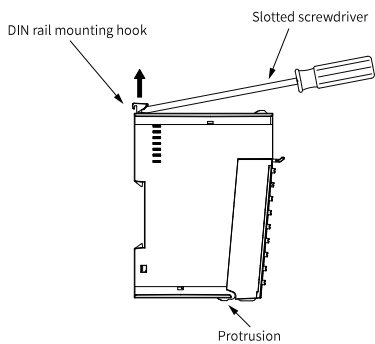

3 Electrical Installation

3.1 Cable Selection

The cable lugs and diameters in the following table are only for reference.

Material Name	Applicable Cable Diameter		KST		Suzhou Yuanli	
	mm ²	AWG	Model	Crimping Tool	Model	Crimping Tool
Tubular lug	0.3	22	E0308	KST2000L	0308	YAC-5
	0.5	20	E0508		0508	
	0.75	18	E7508		7508	
	1.0	18	E1008		1008	
	1.5	16	E1508		1508	

To use other types of tubular lugs, crimp the lug to the cables according to the shape and dimension requirements shown below.

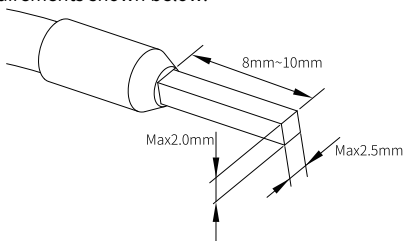

3.2 Terminal Definition

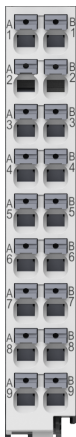

Left Indicator	Left Signal	Left Terminal	Right Terminal	Right Signal	Right Indicator
SSI0 differential data positive side	D0+	A1	B1	D1+	SSI1 differential data positive side
SSI0 differential data negative side	D0-	A2	B2	D1-	SSI1 differential data negative side
SSI0 differential clock positive side	C0+	A3	B3	C1+	SSI1 differential clock positive side
SSI0 differential clock negative side	C0-	A4	B4	C1-	SSI1 differential clock negative side
Floating pin	NC	A5	B5	NC	Floating pin

Left Indicator	Left Signal	Left Terminal	Right Terminal	Right Signal	Right Indicator
SSI0 24V positive side	P0+	A6	B6	P1+	SSI1 24V positive side
SSI0 0V positive side	N0-	A7	B7	N1-	SSI1 0V positive side
Protective grounding	PE	A8	B8	PE	Protective grounding
Module power supply input positive side	24V	A9	B9	0V	Module power supply negative side

3.3 Terminal Wiring

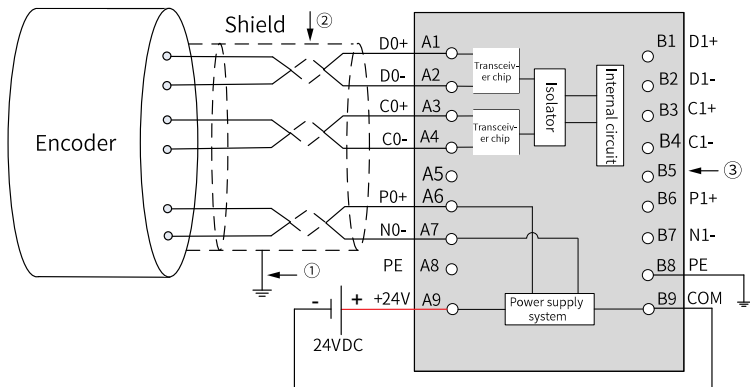

No.	Description
①	Keep good connection between the shielding layer and the PE (if connected to the PE of the SSI module, it is recommended that the PE be properly grounded externally via cables).
②	Use the shielded twisted pair cable as the encoder cable.
③	A5 and B5 are empty terminals with no electrical connections.

Note

Wiring requirements

- Use the shielded twisted pair cable as the encoder cable;
- The PE terminal of the SSI module is recommended to be well grounded through a cable.

When the on-site environment is harsh or the encoder has abnormal data:

- Add a magnetic ring to the shield cable near the module terminals;
 - It is recommended to ground the shielding layer of the encoder's shielded cable at both ends.
-

4 Program Commissioning

4.1 Overview

Before configuring the GL20-2SSI module, it is necessary to understand the functions and principles.

■ SSI absolute encoder value detection

The SSI absolute encoder uploads the encoder value in its data frame to the GL20-2SSI module. The GL20-2SSI module will initialize the transmission of the clock signal in the cycle rate while the GL20-2SSI module processes the encoder value transmitted in synchronization with its cycle rate.

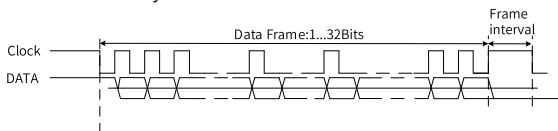

■ Gray code/binary code conversion

You can choose whether to convert the received data frames depending on the encoder type.

- When you choose not to convert the data frames, the received raw SSI data frames will be fully uploaded to the input PDO mapping.
- When Gray code is configured, you can choose to convert the received raw SSI data frames from Gray code to binary code. (No conversion by default.)
- When binary code is configured, you can choose to convert the received raw SSI data frames from binary code to Gray code. (No conversion by default.)

The correspondence between hexadecimal, binary codes, and Gray codes is shown in the table below.

Hexadecimal	Binary Code	Gray Code
0	0000	0000
1	0001	0001
2	0010	0011
3	0011	0010
4	0100	0110

Hexadecimal	Binary Code	Gray Code
5	0101	0111
6	0110	0101
7	0111	0100
8	1000	1100
9	1001	1101
A	1010	1111
B	1011	1110
C	1100	1010
D	1101	1011
E	1110	1001
F	1111	1000



Caution

When the encoding format of SSI absolute encoder is Gray code, if you choose to convert received data frames of the original SSI Gray code type to binary code, certain bits (error bit, parity bit, etc.) will affect the absolute encoder value and can potentially affect consecutive bits. It is recommended not to convert the data frame in this case, but to parse it in the controller. A similar situation does not exist when the SSI absolute encoder type is binary code.

If the data frame is converted, it is considered normal behavior that a non-zero reading on the module channel occurs when the encoder is not connected.

■ Data frame type setting

The transmitted encoder value includes the encoder position of the SSI absolute encoder as well as other bits located before and after the encoder position. In order for the GL20-2SSI module to accurately acquire the encoder position value, set the data frame type according to the following conditions:

- When the SSI absolute encoder is a single-turn 13-bit encoder, select "SingleTurn-13Bit" mode. However, if there are other bits (status bits) in the 13 bits that do not need to be uploaded, select "Variable" mode and set the data bits that need to be uploaded and the most significant bit of valid data.

- When the SSI absolute encoder is a multi-turn 25-bit encoder, select "MultiTurn-25Bit" mode. However, if there are other bits (status bits) in the 25 bits that do not need to be uploaded, select "Variable" mode and set the data bits that need to be uploaded and the most significant bit of valid data.
- When the SSI absolute encoder uses other number of bits, use variable bits in order to get the position value of the SSI absolute encoder.
- Single-turn - 13 Bits Data

Received data frame												
0: MSB	1	2	3	4	5	6	7	8	9	10	11	12
S12	S11	S10	S9	S8	S7	S6	S5	S4	S3	S2	S1	S0

Note

S0 to S12 are the single-turn data bits of the SSI absolute encoder.

- Multi-turn - 25 Bits Data

Received data frame													
0: MSB	1	2	3	4	5	6	7	8	9	10	11	12	13
M11	M10	M9	M8	M7	M6	M5	M4	M3	M2	M1	M0	S12	S11

Received data frame											
14	15	16	17	18	19	20	21	22	23	24	
S10	S9	S8	S7	S6	S5	S4	S3	S2	S1	S0	

Note

S0 to S12 are single-turn data bits of the SSI absolute encoder, and M0 to M11 are multi-turn data bits of the absolute encoder.

- Variable-XX Bits Data

Received data frame													
0: MSB	1	2	3	4	5	6	7	8	9	10	11	12	13
M11	M10	M9	M8	M7	M6	M5	M4	M3	M2	M1	M0	S12	S11

Received data frame															
14	15	16	17	18	19	20	21	22	23	24	25	26	27 to 29	30	31
S10	S9	S8	S7	S6	S5	S4	S3	S2	S1	S0	-	-	-	-	-

Note

S0 to S12 and M0 to M11 are single-turn and multi-turn data bits, and the rest of the bits can be set as stop bits, status bits, etc.

Example 1: For 13-bit encoder without parity check, select "SingleTurn-13Bit" for **Frame Type**. The configuration is shown in the figure below.

Access - 0

Enable access

Coding Mode: gray binary

MulSample Mode: Unenable

Baudrate: 500K

Data Mode: None

Frame Type: SingleTurn-13Bit

Parity Check: None

Direction Invert: No invert sign

PulseTrans Interval: 1024

Frame Size: 13

DataBit Size: 13

Example 2: For 13-bit encoder with parity check, taking odd check as an example, select "SingleTurn-13Bit" for **Frame Type**. The configuration is shown in the figure below, and the received data frame is shown in the table below.

Access - 0

Enable access

Coding Mode: gray binary

MulSample Mode: Unenable

Baudrate: 500K

Data Mode: None

Frame Type: SingleTurn-13Bit

Parity Check: Odd check

Direction Invert: No invert sign

PulseTrans Interval: 1024

Frame Size: 13

DataBit Size: 13

Received data frame													
0: MSB	1	2	3	4	5	6	7	8	9	10	11	12	13
S12	S11	S10	S9	S8	S7	S6	S5	S4	S3	S2	S1	S0	CheckBit

The last bit is the parity check bit. See "Parity Check" below for possible problems when uploading parity check bit.

Example 3: For 24-bit encoder without parity check and status bit, the configuration is shown in the figure below, and the received data frame is shown in the table below.

Access - 0

Enable access

Coding Mode: gray binary

MulSample Mode: Unenable

Baudrate: 500K

Data Mode: None

Frame Type: Variable

Parity Check: None

Direction Invert: No invert sign

PulseTrans Interval: 1024

Frame Size: 24

DataBit Size: 24

Received data frame										
0: MSB	1	2	3	4	...	20	21	22	23	24
M23	M22	M21	M20	M19	...	M4	M3	M2	M1	M0

When the data type of the encoder is 24-bit, the effective data bit is 24, i.e. the MSB is 24.

Example 4: For 25-bit encoder with the last bit as parity check bit, i.e., high 24Bit as the effective data bit (MSB), the received data frame is shown in the table below.

Received data frame										
0: MSB	1	2	3	4	...	21	22	23	24	25
M23	M22	M21	M20	M19	...	M3	M2	M1	M0	Check-Bit

If you need to upload parity check bit, configure it as shown in the figure below; Otherwise, just refer to Example 3.

Access - 0

Enable access

Coding Mode: gray binary

MulSample Mode: Unenable

Baudrate: 500K

Data Mode: None

Frame Type: Variable

Parity Check: Odd check

Direction Invert: No invert sign

PulseTrans Interval: 1024

Frame Size: 24

DataBit Size: 24

Example 5: Single-turn xxBit, multi-turn xxBit encoder, no parity check bit.

Taking single-turn 13Bit, multi-turn 12Bit as an example, the configuration is shown in the figure below, and the received data frame is shown in the table below.

Access - 0

Enable access

Coding Mode: gray binary

MulSample Mode: Unenable

Baudrate: 500K

Data Mode: None

Frame Type: Variable

Parity Check: None

Direction Invert: No invert sign

PulseTrans Interval: 1024

Frame Size: 25

DataBit Size: 25

After receiving the data frame according to this configuration, it is necessary to parse the single- and multi-turn data according to the specifications of the encoder. Other types of encoders can also be configured according to this example, such as the encoder with one frame of data containing velocity, displacement, or acceleration, etc.

Received data frame												
0: MSB	1	2	...	11	12	13	14	15	...	23	24	25
M11	M10	M9	M2	M1	M0	S12	S11	S10	...	S2	S1	S0

S0, S1... are the single-turn data bits of the encoder, M0, M1 are the multi-turn data bits of the encoder. The start bit of single-turn data is S0 and the data length is 13, and the start bit of multi-turn data is M0 and the data length is 12.

■ Rotation direction inversion

The inversion function can adjust the motion direction of the SSI absolute encoder to the direction of the motion axis.

Example:

When using a single-turn 13-bit SSI absolute encoder ($2^{13}=8192$ step, rotation), set the parameters as shown in the table below.

Parameter	Value
Coding Mode	Gray
Frame Type	SingleTurn-13Bit

Parameter	Value
Data Mode	Gray->Bin
Direction Invert	Invert sign

If the encoder position value before inversion is 8192, the encoder position value after inversion is 0.

■ Parity Check

The parity check function is used to determine whether the SSI data frame received by the GL20-2SSI module is abnormal. During the use, if the parameter is set to 25Bit, a 26Bit data frame can be read from the encoder if odd/even check is selected (The SSI absolute encoder itself should support the parity check function). The bit after the least significant bit is the parity check bit. Parity check errors can be fed back via index A0xx.

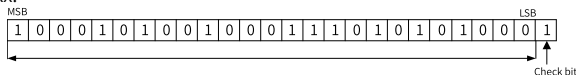

■ Frame interval setting

You can configure the frame interval based on the sampling rate supported by the encoder, including 16 μ s, 32 μ s, 48 μ s, 64 μ s, 512 μ s, 1024 μ s.

Here we take frame interval of 48 μ s as an example:

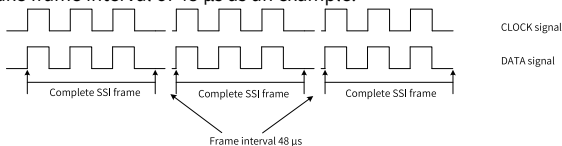

Caution

Different SSI absolute encoders have different frame interval requirements. The frame interval must be configured strictly according to the specifications. If the frame interval is not configured according to the specifications, the input values in the background may be abnormal.

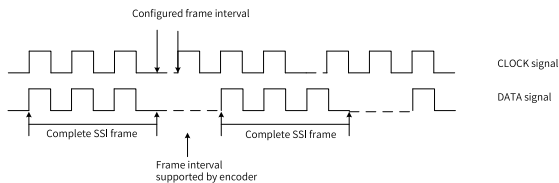

Multi-sampling mode



The multi-sampling mode can be manually enabled only when PulseTrans Interval is set to 512 or 1024.

For multi-sampling mode with frame interval set to 512 μs or 1024 μs , an additional frame of clock signal is sent at an interval of 100 μs after the previous frame of clock signal. The received data will be compared and a fault code will be reported if there is a data difference. For the description and solution for the fault code, see "[Fault Diagnosis](#)" on page 47.

Here we take frame interval of 1024 μs as an example:

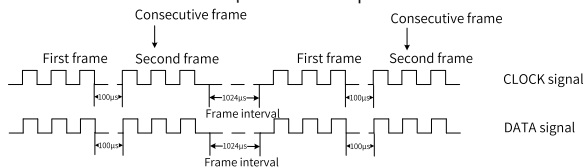

When the frame interval is set to 1024 μs , multi-sampling mode is enabled. The module sends a frame of clock pulse signal first, and sends a second frame of clock pulse signal at an interval of 100 μs after detecting the last clock pulse signal. The received two frames of data will be compared. If there is a difference, the first frame of data will be uploaded and a fault code 0x6032 will be reported to the protocol stack.

4.2 Program Commissioning (InoProShop)

Here we take AM600 as a master with remote EtherCAT bus control as an example.

1. Enable the AM600 PLC as the EtherCAT master and add the GL20-RTU-ECT communication interface module.

- a. In the left **Devices** pane, double-click **Network Configuration** and click the AM600 PLC figure in the upper left corner of the interface. Check the "EtherCAT Master" to enable the PLC as an EtherCAT master.

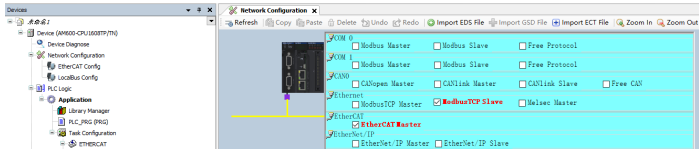

b. Add the GL20-RTU-ECT communication interface module.

- Method 1: In the right **Network Devices List** pane, double-click "GL20-RTU-ECT" to add the module.

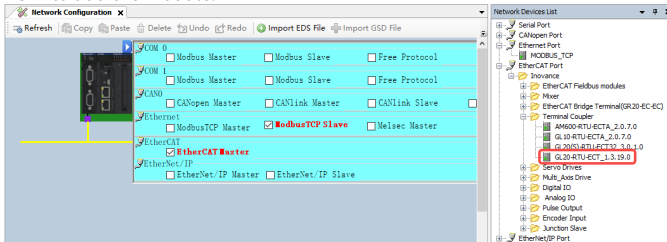

- Method 2: In the left **Devices** pane, right click **ETHERCAT(EtherCAT Master SoftMotion)** ① and select **Add Device**. Select "GL20_RTU_ECT_x.x.x.x" ② in the pop-up dialog box and click **Add Device** ③.

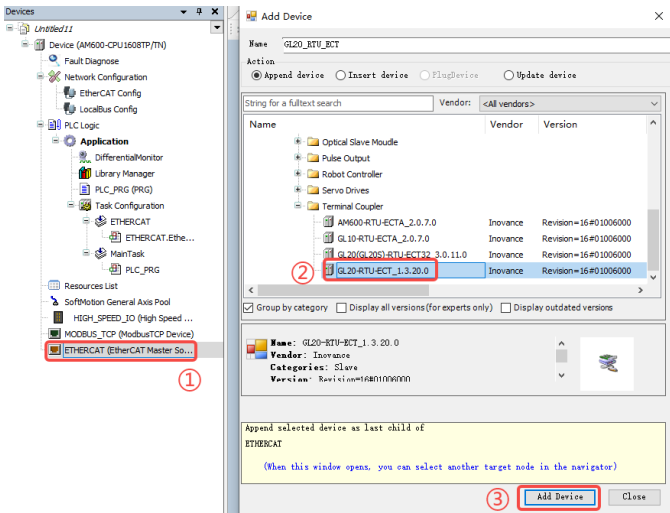

- Method 3: In the left **Devices** pane, right-click on **ETHERCAT(EtherCAT Master SoftMotion)** and select **Scan For Devices**, then click **Scan Devices** and select the scanned GL20-RTU-ECT module, and finally click **Copy all to project**.

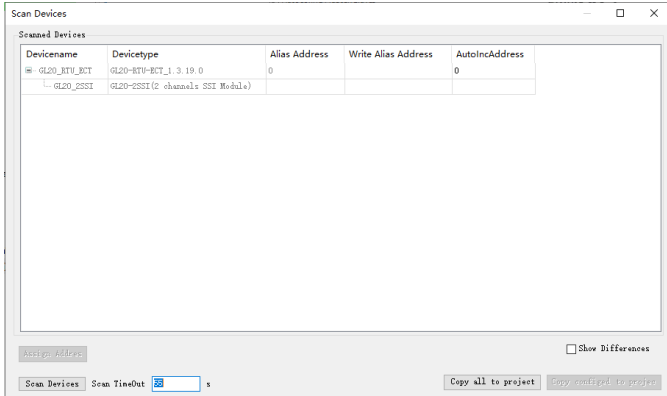

2. Add GL20-2SSI module.

- Method 1: In the left **Devices** pane, double-click on **EtherCAT Config** ①, or in the **Network Configuration** pane, double-click on the GL20-RTU-ECT icon to open the **Hardware Configuration** pane, then in the right **In\Output Module List**, double-click on **GL20_2SSI** ② or drag the GL20_2SSI module and place it after the GL20-RTU-ECT module.

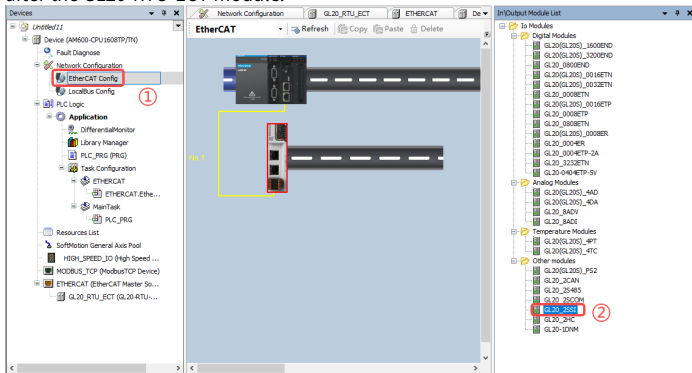

- Method 2: In the left **Devices** pane, right click on "GL20_RTU_ECT" ① and select **Add Device**. Select "GL20-2SSI" ② in the pop-up dialog box and click **Add Device** ③.

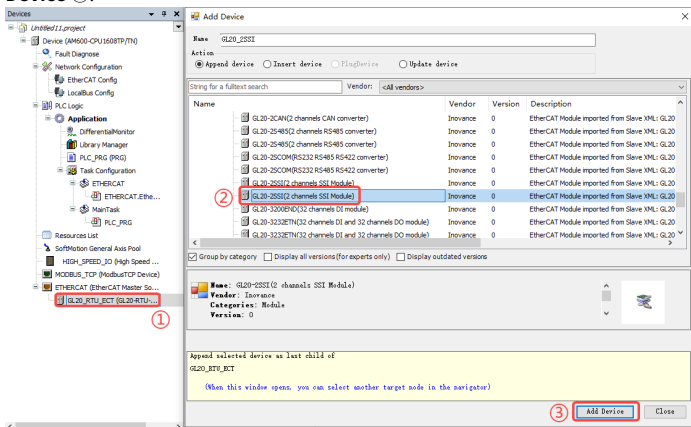

- Method 3: In the left **Devices** pane, right-click on **ETHERCAT(EtherCAT Master SoftMotion)** and select **Scan For Devices**, then click **Scan Devices** and select the scanned GL20-2SSI module, and finally click **Copy all to project**.

3. Configure channels of the GL20-2SSI module.

You can configure each channel of the module independently and set relevant parameters depending on the encoder. As an example, we use an absolute encoder and set coding mode of channel 1 to Gray code, data frame size to 13 bits, and frame interval to 32 μ s, without parity check.

In the left **Devices** pane, double-click on **GL20_2SSI** ①, or in the **Hardware Configuration** pane, double-click on the GL20-RTU-ECT icon to open the configuration page, then click **Channels Config** ② to configure the channel parameters. The parameters for channel configuration are shown in the following

table.

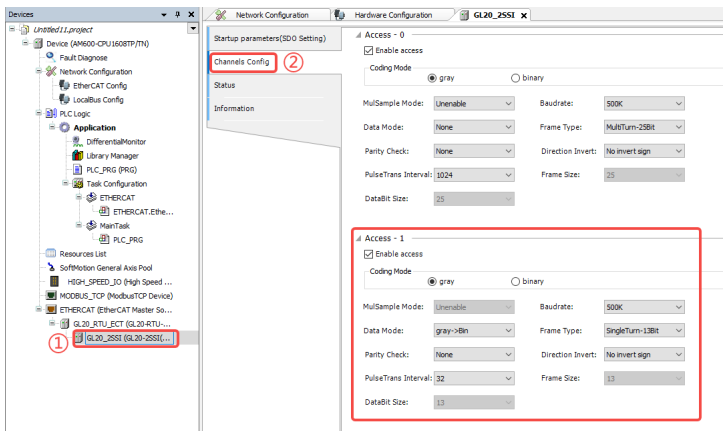

Parameter	Description	Value	Default
Enable access	Check to enable the channel	<ul style="list-style-type: none"> ● Check ● Uncheck 	Checked
Coding Mode	Select the coding mode according to the encoder type.	<ul style="list-style-type: none"> ● Gray ● Binary 	Gray
MultiSample Mode	It determines the validity of the encoder position value, and sends a fault code to the host if it is invalid.	<ul style="list-style-type: none"> ● Unenable ● Enable 	Unenable
Data Mode	<ul style="list-style-type: none"> ● When Coding Mode is set to "gray", configure this parameter if you need to upload data as binary code. ● When Coding Mode is set to "binary", use the default value. 	<ul style="list-style-type: none"> ● None ● Gray->Bin 	None

Parameter	Description	Value	Default
Parity Check	If the assigned parity check is for a 25-bit encoder, 26 bits can be read from the encoder. The bit after the least significant bit will be judged as the parity bit, and parity errors will be sent to the host in the form of a fault code.	<ul style="list-style-type: none"> ● None ● Odd check ● Even check 	None
PulseTrans Interval	Set the interval according to the encoder specifications. If you need to increase the response speed of the encoder, you can adjust this parameter according to the performance of the encoder. This parameter is strongly related to the encoder performance.	16/32/48/64/512/1024	1024
DataBit Size	This parameter configuration is available only when Frame Type is set to "Variable".	0 to 32	-
Baud rate	The baud rate affects the accuracy of the encoder as well as the rate of position updates. You can adjust it according to the actual transmission rate and performance of the encoder. This parameter is strongly related to the encoder performance.	100K/200K/300K/400K/ 500K/1000K/1250K/1500K/ 2000K	500K
Frame Type	It is recommended to select "Variable" when there are status bits in the encoder bits. This parameter should be used in combination with "DataBit Size" and "Frame Size".	<ul style="list-style-type: none"> ● SingleTurn-13Bit ● MultiTurn-25Bit ● Variable 	Multi-Turn-25Bit

Parameter	Description	Value	Default
Direction Invert	The inversion function can adjust the motion direction of the absolute encoder to the direction of the motion axis.	<ul style="list-style-type: none"> No invert sign Invert sign 	No invert sign
Frame Size	This parameter configuration is available only when Frame Type is set to "Variable".	0 to 32	-

4. After successful compiling, download the project and run it.

4.3 Program Commissioning (TwinCAT)

Prerequisite

Obtain XML file for the GL20-RTU-ECT module from the software and debugging tools tab on the GL20 series product page at <https://www.inovance.com>

Operating procedure

1. Copy the XML file to the TwinCAT installation directory: ../TwinCAT/3.1/Config/IO/EtherCat.

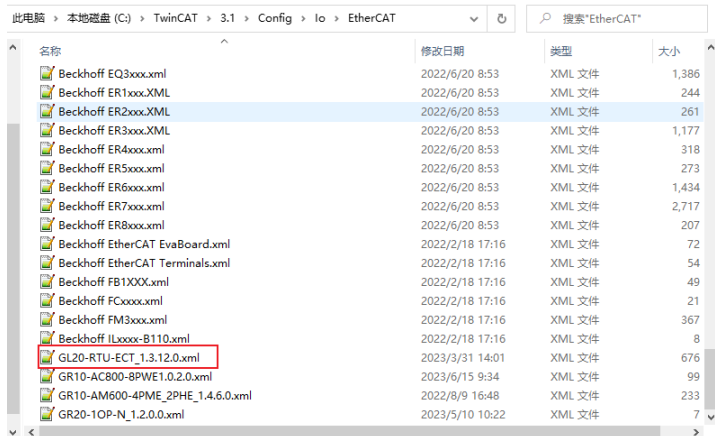

2. Create a TwinCAT project.

3. In the **Solution Explorer** pane, click **I/O** ①, right-click on **Devices** ② and select **Scan** ③.

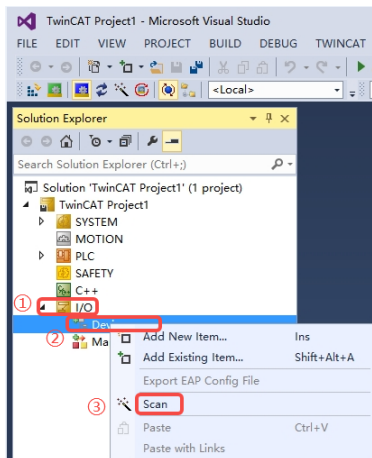

4. In the pop-up dialog, select the network card corresponding to the network port of GL20-RTU-ECT module and click **OK**.

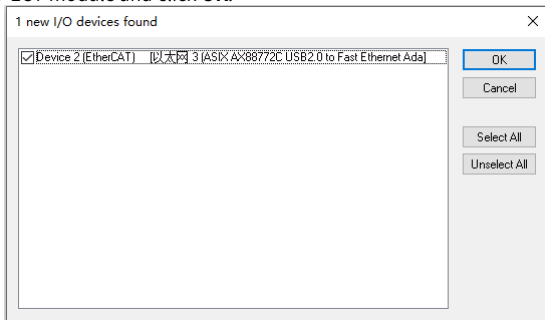

5. In the pop-up dialog, click **Yes** and then **Yes**.

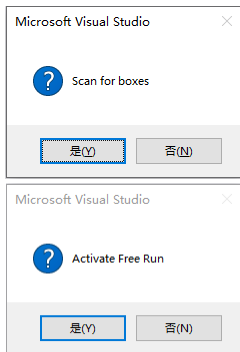

Under **Device 2 (EtherCAT)**, you can view the GL20-RTU-ECT and GL20-SSI configuration information.

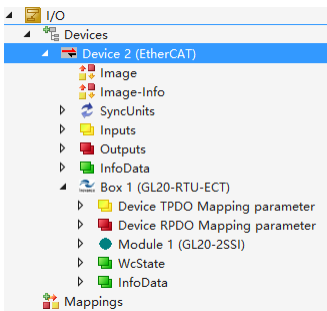

6. Configure GL20-2SSI module parameters.

Click **Box 1 (GL20-RTU-ECT)** ① and click **CoE - Online** ② tab in the opened interface on the right side. Click "+" ③ before the index "8000:0", double-click the corresponding value in the **Value** column, and configure the GL20-2SSI module parameters in the pop-up dialog. After configuration is completed, click **OK**. The parameters for channel configuration are shown in the following table.

The collected data information of the module will be displayed at the bottom of the interface.

The screenshot shows the TwinCAT Project19 interface. The 'Startup' tab is active, displaying a table of configuration parameters. A red box highlights the entry '0x8000: 255 Chn_0 ConfigData'. Below this table is another table with columns: Name, Online, Type, Size, >Add..., In/Out, User..., and Linked to.

Index	Name	Flags	Value	Unit
* 1C120	RuPDO assign	RO	> 1 <	
* 1C130	TuPDO assign	RO	> 2 <	
* 1C320	SM output parameter	RO	> 32 <	
* 1C330	SM input parameter	RO	> 32 <	
* 30100	Port 0 error counter	RO	> 4 <	
* 30110	Port 1 error counter	RO	> 4 <	
* 30120	ESC error counter	RO	> 4 <	
* 30160	Station address	RO	> 4 <	
* 3020	Fpga soft version	RO	0x00010402 (66562)	
* 30210	Module software version	RO	> 2 <	
* 30000	TS51 RV data	RO	> 12 <	
0x8000	255 Chn_0 ConfigData	RW	> 12 <	
800001	Chn_0 enable and BaudRate	RW	0x0401 (1025)	
800002	Chn_0 Frame Format	RW	0x0104 (260)	
800003	Chn_0 ParityCheck and Pulse...	RW	0x0000 (0)	
800004	Chn_0 FrameLength and MSB	RW	0x0020 (32)	
800005	Chn_0 reserve0	RW	0x0000 (0)	
800006	Chn_0 reserve1	RW	0x0000 (0)	
800007	Chn_1 enable and BaudRate	RW	0x0401 (1025)	

Name	Online	Type	Size	>Add...	In/Out	User...	Linked to
LBUS status	8	UINT	2.0	26.0	Input	0	
Fault ID	0	UINT	2.0	28.0	Input	0	
Ch0 Para Input	0	UDINT	4.0	30.0	Input	0	
Ch0 Reserve d...	0	UDINT	4.0	34.0	Input	0	
Ch0 Reserve d...	0	UDINT	4.0	38.0	Input	0	
Ch0 Reserve d...	0	UDINT	4.0	42.0	Input	0	
Ch0 Reserve d...	0	UDINT	4.0	46.0	Input	0	
Ch0 Reserve d...	0	UDINT	4.0	50.0	Input	0	
Ch1 Para Input	0	UDINT	4.0	54.0	Input	0	

Table 4-1 0x800x: Channel Configuration

Index	0x8000: Channel Configuration				
Subindex	Name	Data Type	Access Mode	Mapping	Default Value
0	SubIndex 000	USINT	RW	NO	-
1	Chn_0 Enable and BaudRate	UINT	RW	NO	0x0401 (1025)
2	Chn_0 Frame Format	UINT	RW	NO	0x0104 (260)
3	Chn_0 Parity Check and Pulse interval	UINT	RW	NO	0x0000 (0)
4	Chn_0 Frame Length and Data Length	UINT	RW	NO	0x1919 (25)
5	Chn_0 Reserve0	-	-	-	-
6	Chn_0 Reserve0	-	-	-	-

Index	0x8000: Channel Configuration				
Sub-index	Name	Data Type	Access Mode	Mapping	Default Value
7	Chn_1 Enable and BaudRate	UINT	RW	NO	0x0401 (1025)
8	Chn_1 Frame Format	UINT	RW	NO	0x0104 (260)
9	Chn_1 Parity Check and Pulse interval	UINT	RW	NO	0x0000 (0)
10	Chn_1 Frame Length and Data Length	UINT	RW	NO	0x1919 (25)
11	Chn_1 Reserve0	-	-	-	-
12	Chn_1 Reserve0	-	-	-	-

Table 4-2 Sub-index 001

Bit	Description
Bit 0	Channel 0 enable <ul style="list-style-type: none"> ● 0: Disable ● 1: Enable
Bit 1	MulSample Mode <ul style="list-style-type: none"> ● 0: Disable ● 1: Enable
Bit 2 to 7	Reserved
Bit 8 to 11	Baud rate (bps) <ul style="list-style-type: none"> ● 0: 100k ● 1: 200k ● 2: 300k ● 3: 400k ● 4: 500k ● 5: 1000k ● 6: 1250k ● 7: 1500k ● 8: 2000k
Bit 12 to 15	Reserved

Table 4-3 Sub-index 002

Bit	Description
Bit 0	Coding Mode <ul style="list-style-type: none"> ● 0: Gray code ● 1: Binary code
Bit 1 and 2	Data Mode <ul style="list-style-type: none"> ● 0: Gray code ->binary code ● 1: Binary code ->Gray code ● 2: None
Bit 3 to 7	Reserved
Bit 8 and 9	Frame Type <ul style="list-style-type: none"> ● 0: SinglTurn-13Bit ● 1: MultiTurn-25Bit ● 2: Variable
Bit 10 to 15	Reserved

Table 4-4 Sub-index 003

Bit	Description
Bit 0 to 2	Parity Check <ul style="list-style-type: none"> ● 0: None ● 1: Odd check ● 2: Even check
Bit 3	Direction Invert <ul style="list-style-type: none"> ● 0: No invert sign ● 1: Invert sign
Bit 4 to 7	Reserved

Bit	Description
Bit 8 to 10	PulseTrans Interval <ul style="list-style-type: none"> ● 0: 1024 ● 1: 16 ● 2: 32 ● 3: 48 ● 4: 64 ● 5: 512
Bit 11 to 15	Reserved

Table 4-5 Sub-index 004

Bit	Description
Bit 0 to 7	Frame Size
Bit 8 to 15	DataBit Size

Note

Subindex 007 to subindex 0010 are the same as subindex 001 to subindex 004.

7. After successful compiling, download the project and run it.

4.4 Program Commissioning (TIA Portal)

For details, see *GL20-RTU-PN Communication Interface Module User Guide*.

5 Troubleshooting

When the ERR indicator is ON, it indicates that the module is faulty. The module reports a fault code, which can be obtained through the diagnostic data object dictionary value in the "CoE Online" interface, as shown below. For the module installed in slot n (n = 0 to 31), the object dictionary definition for index 0xA000 +0x40*n is shown in the table below.

General		<input type="button" value="Read this page"/> <input checked="" type="checkbox"/> Auto Update <input checked="" type="radio"/> Offline from ESI file <input type="radio"/> Online from device			
Process Data(PDO Setting)	Index:Subindex	Name	Flags	Type	Value
Startup parameters(SDO Setting)	16#100A:16#00	Software version	RO	STRING(13)	
Online	16#1018:16#00	Identity	RO	USINT	
	16#1C00:16#00	Sync manager type	RO	USINT	
	16#1C12:16#00	RxPDO assign	RO	USINT	
CoE Online	16#1C13:16#00	TxPDO assign	RO	USINT	
Device Diagnosis	16#1C32:16#00	SM output parameter	RO	USINT	
	16#1C33:16#00	SM input parameter	RO	USINT	
EtherCAT I/O Mapping	16#3010:16#00	Port 0 error counter	RO	USINT	
	16#3011:16#00	Port 1 error counter	RO	USINT	
EtherCAT IEC Objects	16#3012:16#00	ESC error counter	RO	USINT	
Status	16#3016:16#00	Station address	RO	USINT	
	16#3020:16#00	Fpga sortf version	RO	UBINT	
Information	16#3021:16#00	Module software version	RO	USINT	
	16#6000:16#00	2SSI RX_data	RO	USINT	
	16#8000:16#00	2SSI Chn_0 ConfigData	RW	USINT	
	16#A000:16#00	2SSI module Diagnosis information	RO	USINT	
	16#01	SSI Module Diagnosis information	RO	UINT	
	16#02	Ch0 Diagnosis information	RO	UINT	
	16#03	Ch1 Diagnosis information	RO	UINT	
	16#04	reserve0	RO	UINT	
	16#05	reserve1	RO	UINT	
	16#06	reserve2	RO	UINT	
	16#07	reserve3	RO	UINT	
	16#08	reserve4	RO	UINT	
	16#09	reserve5	RO	UINT	
	16#0A	reserve6	RO	UINT	
	16#0B	reserve7	RO	UINT	
	16#0C	reserve8	RO	UINT	

Index	0xA000+0x40*n: 2SSI module diagnostic information				
Subindex	Name	Data Type	Access Mode	Mapping	Default Value
0	2SSI module fault information	USINT	RO	NO	2
1	2SSI module channel 0 fault information	UINT	RO	NO	0
2	2SSI module channel 1 fault information	UINT	RO	NO	0

■ Module fault code

Fault code	Description	Solution
0x5003	External 24 V power supply failure	Check the isolated power supply of the module.

■ Module channel fault code

Fault code	Description	Solution
0x6030	Channel output 24V short-circuit	Check for short circuit in module or encoder wiring.
0x6031	Channel communication error	<ul style="list-style-type: none"> • Check whether the positive and negative terminals of the DATA signal line and the Clock signal line are reversed. If yes, correct the wiring. • See solution for 0x6032.
0x6032	Channel data error	<ul style="list-style-type: none"> • Check the encoder surroundings for interference. • Check whether the configured frame interval time matches the encoder. • Replace the sensor.

6 Appendix: Version Matching Information

Contact Inovance technical support to obtain the firmware of GL20-2SSI module and the firmware of communication interface module. XML files and the InoProShop software can be downloaded from the software and debugging tools tab on the GL20 series product page at <https://www.inovance.com>. The following table describes the version matching information.

GL20-2SSI Module Firmware Version	Communication Interface Module Firmware Version	XML/GSD File Version	InoProShop Version
Board software: 1.1.7.0 and later Logic software: 0.1.12.0 and later	<ul style="list-style-type: none">● GL20-RTU-ECT: Board software 2.4.12.0 and later, logic software 0.1.3.2 and later● GL20-RTU-ECT: Board software 2.2.0.0 and later, logic software 0.1.3.3 and later	<ul style="list-style-type: none">● GL20-RTU-ECT: 1.3.12.0 and later● GL20-RTU-PN: 20230522 and later	InoProShop: V1.7.3 SP5 and later