



PS00014215A01

## GL20-1DNM DeviceNet Master Module User Guide

Suzhou Inovance Technology Co., Ltd.

Add.: No.52, Tian'e Dang Road, Wuzhong District,  
Suzhou 215104, P.R. China

Tel: (0512) 6637 6666 Fax: (0512) 6285 6720

[www.inovance.com](http://www.inovance.com)





# Preface

## ■ Introduction

The GL20-1DNM is GL20 series 1-channel DeviceNet master module. It adapts to AC700/AC800/AM500 series products via the GL20-RTU-ECT32 communication interface module.

This guide describes the product information, mechanical installation, electrical installation, fault diagnosis, programming examples, and version information of the product.

## ■ Standards Compliance

The following table lists the certifications, directives, and standards that the product may comply with. For details about the acquired certificates, see the certification marks on the product nameplate.

Certification	Directive		Standard
CE Certification	EMC Directive	2014/30/EU	<b>24 VDC products</b> EN 61131-2 <b>220 VAC products</b> EN 61131-2 EN 61000-3-2 EN 61000-3-3
	LVD	2014/35/EU	EN 61010-1 EN 61010-2-201
	RoHS Directive	2011/65/EU amended by (EU) 2015/863	EN IEC 63000
UL/cUL Certification	-	-	UL 61010-1 UL 61010-2-201 CAN/CSA-C22.2 No. 61010-1 CSA C22.2 NO. 61010-2-201
KCC Certification	-	-	-

Certification	Directive		Standard
EAC Certification	-		-
UKCA Certification	Safety Regulations	Electrical Equipment (Safety) Regulations 2016	EN 61010-1 EN 61010-2-201
	EMC Regulations	Electromagnetic Compatibility Regulations 2016	<b>24 VDC products</b> EN 61131-2 <b>220 VAC products</b> EN 61131-2 EN 61000-3-2 EN 61000-3-3
	RoHS Regulations	Directive (RoHS) Regulations 2012	EN IEC 63000

## ■ More Data

Name	Data Code	Description
GL20-RTU-ECT32 Communication Interface Module User Guide	PS00013434	This guide describes the product information, installation, wiring, programming debug and fault diagnostics of the product.
GL20-1DNM DeviceNet Master Module User Guide	PS00014215	This guide describes the product information, mechanical installation, electrical installation, fault diagnosis, programming examples, and version information of the product.

## ■ Revision History

Date	Version	Description
February 2024	A01	<ul style="list-style-type: none"><li>● Updated "<a href="#">1.2 Components</a>" on <a href="#">page 10</a></li><li>● Updated "<a href="#">1.3 Specifications</a>" on <a href="#">page 12</a></li><li>● Updated "<a href="#">2.1 Installation Precautions</a>" on <a href="#">page 16</a></li></ul>
October 2023	A00	Initial release

## ■ How to Obtain

This guide is not delivered with the product. You can obtain the PDF version by the following methods:

- Do keyword search under **Service and Support** at <http://www.inovance.com>.
- Scan the QR code on the product with your smart phone.
- Scan the QR code below to install the app, where you can search for and download manuals.



## ■ Warranty Disclaimer

Inovance provides warranty service within the warranty period (as specified in your order) for faults or damage that occur during normal operation. Maintenance will be charged after the warranty expires.

Within the warranty period, maintenance fee will be charged for the following damage:

- Damage caused by operations not following the instructions in the user guide
- The product is damaged due to fire, flood, and abnormal voltage.
- Damage caused by unintended use of the product

- Damage caused by use beyond the specified scope of application of the product
- Damage or secondary damage caused by force majeure (natural disaster, earthquake, and lightning strike)

The maintenance is charged according to the latest Price List of Inovance. If otherwise agreed upon, the terms and conditions in the agreement shall prevail.



For details, see Product Warranty Card.

# Fundamental Safety Instructions

## ■ Safety Precautions

1. Before installing, using, and maintaining this equipment, read the safety information and precautions thoroughly, and comply with them during operations.
2. To ensure personal and equipment safety, observe the notes indicated on the product labels and all the safety instructions in the user guide.
3. "CAUTION", "WARNING", and "DANGER" in the user guide only indicate some of the precautions that need to be followed; they just supplement the safety precautions.
4. Use this equipment according to the designated environment requirements.  
Damage caused by improper use is not covered by warranty.
5. Inovance shall take no responsibility for any personal injury or property damage caused by improper use.

## ■ Safety Levels and Definitions

-  **危险** "DANGER" indicates that failure to comply with the notice can result in severe personal injury or even death.
-  **警告** "WARNING" indicates that failure to comply with the notice may result in death or severe personal injury.
-  **注意** "CAUTION" indicates that failure to comply with the notice may result in minor or moderate personal injury or equipment damage. Keep this manual properly for future use and deliver it to the end user.

### Control System Design

#### 危险

- Provide a safety circuit outside the PLC so that the control system can still work safely once external power failure or PLC fault occurs.
- Add a fuse or circuit breaker because the module may smoke or catch fire due to long-time overcurrent caused by operation above rated current or load short-circuit.

 警告

- An emergency stop circuit, a protection circuit, a forward/reverse operation interlocked circuit, and an upper position limit and lower position limit interlocked circuit must be set in the external circuits of PLC to prevent damage to the machine.
- To ensure safe operation, for the output signals that may cause critical accidents, please design external protection circuit and safety mechanism.
- Once the CPU of the PLC detects an exception in the system, all outputs may be closed; however, when a fault occurs in the controller circuit, the output may not be under control. Therefore, it is necessary to design an appropriate external control circuit to ensure normal operation.
- If the PLC output units such as relays or transistors are damaged, the output may fail to switch between ON and OFF states according to the commands.
- The PLC is designed to be used in an indoor electrical environment (overvoltage category II). The power supply must have a system-level surge protector, assuring that overvoltage due to lightning shock can't be applied to the PLC's power supply input terminals, signal input terminals and output terminals, to prevent damage to the equipment.

## Installation

 警告

- Installation must be carried out by the specialists who have received the necessary electrical training and understood enough electrical knowledge.
- Disconnect all external power supplies of the system before removing/installing the module. Failure to do so may result in electric shock, module fault or malfunction.
- Do not use the PLC where there are dust, oil smoke, conductive dust, corrosive or combustible gases, or exposed to high temperature, condensation, wind & rain, or subject to vibration and impact. Electric shock, fire and malfunction may also result in damage or deterioration to the product.
- The PLC is open-type equipment that must be installed in a control cabinet with lock (cabinet housing protection > IP20). Only the personnel who have received the necessary electrical training and understood enough electrical knowledge can open the cabinet.

 注意

- Prevent metal filings and wire ends from dropping into ventilation holes of the PLC during installation. Failure to comply may result in fire, fault and malfunction.
- Ensure there are no foreign matters on ventilation surface. Failure to comply may result in poor ventilation, which may cause fire, fault and malfunction.
- Ensure the module is connected to the respective connector securely and hook the module firmly. Improper installation may result in malfunction, fault or fall-off.

### Wiring



危险

- Wiring must be carried out by personnel who have received the necessary electrical training and understood enough electrical knowledge.
- Disconnect all external power supplies of the system before wiring. Failure to comply may result in electric shock, module fault or malfunction.
- Perform good insulation on terminals so that insulation distance between cables will not reduce after cables are connected to terminals. Failure to comply may result in electric shock or damage to the equipment.



注意

- To avoid electric shock, cut off the power supply before connecting the product to the power supply.
- The input power of the product must meet the specifications listed in this guide. If the power input does not meet the specifications, the equipment may be damaged. Thus, check regularly that the DC power provided by the switching-mode power supply unit is stable.

### Operation and Maintenance



注意

- Maintenance & inspection must be carried out by personnel who have the necessary electrical training and experience.
- Do not touch the terminals while the power is on. Failure to comply may result in electric shock or malfunction.
- Disconnect all external power supplies of the system before cleaning the module. Failure to comply may result in electric shock.
- Disconnect all external power supplies of the system before removing the module or connecting/removing the communication wirings. Failure to comply may result in electric shock or malfunction.

## Safety Recommendations

- In the position where the operator directly contacts the machinery part, for example, where a machinery tool is loaded/unloaded, or where a machine runs automatically, the onsite manual operating devices and any other alternative means must be carefully arranged and designed so that they are independent of the programmable controller and can start or terminate the automatic running of the system.
- If you need to modify the program while the system is running, use the lock function or other protective measures. Ensure that only authorized personnel can make the necessary modifications.

## Disposal



- Treat the scrapped product as industrial waste. Dispose of the battery according to local laws and regulations.
- Recycle retired equipment by observing industry waste disposal standards to avoid environmental pollution.

# 1 Product Information

## 1.1 Model Number and Nameplate

GL 20 - 1 DNM

①      ②      ③      ④

<p>① <b>Product Information</b> GL: General local module</p>	<p>③ <b>Number of Master Channels</b> 1: 1x channel</p>
<p>② <b>Series Number</b> 20: 20 series module</p>	<p>④ <b>Module Type</b> DNM: DeviceNet master module</p>

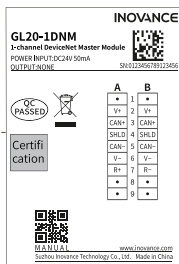





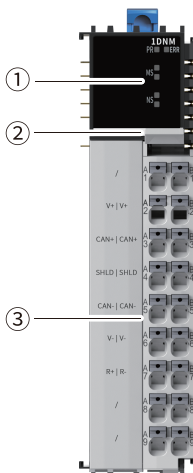

The data for ordering the product is shown below.

Model	Description	Product Code	Applicable Model
GL20-1DNM	GL20 series 1-channel DeviceNet master module	01440484	AC700/AC800/AM500 series

## 1.2 Components



No.	Interface	Description				
①	Signal indicator	PR (POWER +RUN)	Power/Run indicator	Yellow green	<ul style="list-style-type: none"> <li>● OFF: The module is not powered on or is faulty.</li> <li>● Flashing slowly (1s off, 200ms on): The module is powered on but not addressed successfully.</li> <li>● Flashing quickly (200 ms off, 200 ms on): The module is addressed successfully.</li> <li>● Steady ON: The module is running normally.</li> </ul>	
		ERR	Fault indicator	Red	ON when 24 V power failure or error occurs. For details, see " <a href="#">Fault Diagnosis</a> " on <a href="#">page 37</a> .	
		MS	Module status indicators	The meanings of the MS and NS indicators needs to be determined comprehensively. For details, see the following table.		
		NS	Network status indicator			
②	Color identification		Red: Digital output		Orange: Analog output	
			Gray: Digital input		Green: Analog input	
			White: Communication		Blue: Others	
③	User terminals	For details, see " <a href="#">3.2 Terminal Definitions</a> " on <a href="#">page 22</a>				

The following table describes the meanings of the MS and NS indicators.

MS indicator		NS indicator		Meaning
Red	Green	Red	Green	
OFF	OFF	OFF	OFF	The module is not powered on.
OFF	Steady ON	OFF	Steady ON	The module runs normally.
			Blinking	The DeviceNet communication bus is not configured with a slave.
		Blinking	Steady ON	<ul style="list-style-type: none"> <li>A slave on the DeviceNet communication bus is disconnected.</li> <li>The CAN node enters the BusOff state and disconnects from CAN bus.</li> </ul>
Steady ON	OFF	Steady ON	OFF	<ul style="list-style-type: none"> <li>EtherCAT communication bus is not connected.</li> <li>The module is not connected to the 24 V power.</li> <li>MAC ID conflict</li> </ul>
Flashing red and green alternatively		Flashing red and green alternatively		<ul style="list-style-type: none"> <li>The module is acquiring the configuration information.</li> <li>The module fails to receive the DeviceNet slave configuration data.</li> </ul>

## 1.3 Specifications

### ■ General specifications

Item	Specification
IP rating	IP20
Dimensions (W x H x D)	24 mm x 100 mm x 75 mm
Weight	Approx. 105 g

### ■ Power supply specifications

Item	Specification
Rated bus input voltage	5 VDC (4.75 VDC to 5.25 VDC)
Rated bus input current	100 mA (typical@5 V)
Rated terminal input voltage	11 VDC to 25 VDC
Rated terminal input current	50 mA (typical@24 V)

Item	Specification
Rated terminal output voltage	/
Rated terminal output current	/

## ■ Communication Specifications

Item	Specification																
Number of channels	1x CAN communication channel																
Terminal Type	Push-in terminal																
Communication rate	125 kbit/s, 250 kbit/s, and 500 kbit/s (default 125 kbit/s)																
Termination resistor	The termination resistor is connected by shorting R+ and R- terminals.																
Communication medium	<ul style="list-style-type: none"> <li>• 4-core flat cable: 2x signal wires and 2x power wires</li> <li>• 5-core shielded cable: 2x signal wires, 2x power wires, and 1x shielded wire</li> </ul>																
Communication distance of 4-core flat cable	<table border="1"> <thead> <tr> <th>Communication rate</th> <th>Length of the main cable</th> <th>Branch length</th> <th>Total branch length</th> </tr> </thead> <tbody> <tr> <td>125 kbit/s</td> <td>500 m max.</td> <td>6 m max.</td> <td>156 m max.</td> </tr> <tr> <td>250 kbit/s</td> <td>250 m max.</td> <td>6 m max.</td> <td>78 m max.</td> </tr> <tr> <td>500 kbit/s</td> <td>100 m max.</td> <td>6 m max.</td> <td>39 m max.</td> </tr> </tbody> </table>	Communication rate	Length of the main cable	Branch length	Total branch length	125 kbit/s	500 m max.	6 m max.	156 m max.	250 kbit/s	250 m max.	6 m max.	78 m max.	500 kbit/s	100 m max.	6 m max.	39 m max.
	Communication rate	Length of the main cable	Branch length	Total branch length													
	125 kbit/s	500 m max.	6 m max.	156 m max.													
250 kbit/s	250 m max.	6 m max.	78 m max.														
500 kbit/s	100 m max.	6 m max.	39 m max.														
Communication distance of 5-core shielded cable	<table border="1"> <thead> <tr> <th>Communication rate</th> <th>Length of the main cable</th> <th>Branch length</th> <th>Total branch length</th> </tr> </thead> <tbody> <tr> <td>125 kbit/s</td> <td>265 m max.</td> <td>6 m max.</td> <td>135 m max.</td> </tr> <tr> <td>250 kbit/s</td> <td>150 m max.</td> <td>6 m max.</td> <td>48 m max.</td> </tr> <tr> <td>500 kbit/s</td> <td>75 m max.</td> <td>6 m max.</td> <td>35 m max.</td> </tr> </tbody> </table>	Communication rate	Length of the main cable	Branch length	Total branch length	125 kbit/s	265 m max.	6 m max.	135 m max.	250 kbit/s	150 m max.	6 m max.	48 m max.	500 kbit/s	75 m max.	6 m max.	35 m max.
	Communication rate	Length of the main cable	Branch length	Total branch length													
	125 kbit/s	265 m max.	6 m max.	135 m max.													
250 kbit/s	150 m max.	6 m max.	48 m max.														
500 kbit/s	75 m max.	6 m max.	35 m max.														
Number of slaves	63 max.																

## ■ Software specifications

Item	Specification
Max. PDO of ETC32 module occupied by the DNM module <sup>[1]</sup>	<ul style="list-style-type: none"><li>● Input: 120 bytes</li><li>● Output: 120 bytes</li></ul>
Max. PDO of DNM module occupied by the DeviceNet slave <sup>[2]</sup>	<ul style="list-style-type: none"><li>● Input: 960 bytes</li><li>● Output: 960 bytes</li></ul>
Max. number of modules mounted to GL20-RTU-ECT32 communication interface module	4 <b>Note: The modules must be mounted in the first four slots of the GL20-RTU-ECT32 communication interface module.</b>
Cycle limit set for GL20-RTU-ECT32 communication interface module (when used with this module)	1 ms and more
Recommended cycle time of DeviceNet slave with the maximum PDO	1000 ms and more

## Note

- [1]: When the PDO from the DNM module is transmitted in the ECT32 module, it utilizes the maximum PDO data capacity that the ECT32 module can handle.
- [2]: When the PDO from the DNM module is transmitted in the DNM module, it utilizes the maximum PDO data capacity that the DNM module can handle. When the PDO from the DeviceNet slave exceeds 120 bytes, the PDO is transmitted in split frames in the ECT32 module.

## 1.4 Environmental Specifications

Item	Specification
Working environment	No corrosive and flammable gas and no excessive conductive dust
Altitude	≤2000 m

Item	Specification
Pollution degree	2
Noise immunity	2 kV on power supply line (Conforms to IEC 61000-4-4)
Overvoltage category	I
EMC immunity level	Zone B, IEC61131-2
Vibration resistance	<ul style="list-style-type: none"> <li>● Operating: Tested according to IEC 60068-2-6. 5 Hz to 8.4 Hz, 3.5 mm, 8.4 Hz to 200 Hz, 1g, 10 cycles each in X, Y and Z directions.</li> <li>● Transport: Tested according to IEC 60068-2-64. 5 Hz to 100 Hz, 0.01 g<sup>2</sup>/Hz; 200 Hz, 0.001 g<sup>2</sup>/Hz, 1.14 g, 30 min each in X, Y and Z directions.</li> </ul>
Shock resistance	<ul style="list-style-type: none"> <li>● Operating: Tested according to IEC 60068-2-27. 15 g, 11 ms, 18 shocks.</li> <li>● Transport: Tested according to IEC 60068-2-27. 15 g, 11 ms, 18 shocks.</li> </ul>
Operating temperature/humidity	<ul style="list-style-type: none"> <li>● Operating temperature: -20°C to +55°C</li> <li>● Relative humidity: 10% to 90% RH, non-condensing</li> </ul>
Storage temperature/humidity	<ul style="list-style-type: none"> <li>● Storage temperature: -40°C to +70°C</li> <li>● Relative humidity: &lt;90% RH, non-condensing</li> </ul>

## 2 Mechanical Installation

### 2.1 Installation Precautions

- Before installing or removing the module, ensure that the module is powered off.
- Do not hot swap the modules. Otherwise, the modules may be damaged by overcurrent or overvoltage, and the communication interface module or PLC may be subject to restart, user data loss or corruption.
- 坏Prevent the enclosure or terminals of the module from dropping or suffering from impact or shock.

### 2.2 Mounting Dimensions

#### ■ Module

The module mounting dimensions (in mm) are shown in the figure below.

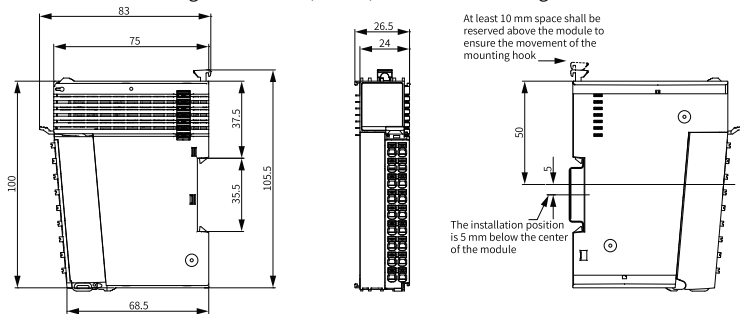

#### ■ Cable

The module mounting dimensions (in mm) with cables are shown in the figure below.

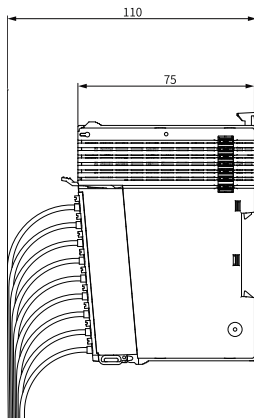

## 2.3 Installation Method

The module is mounted onto a DIN rail in conformity with IEC 60715 (width: 35 mm, thickness: 1 mm). The dimensions (unit: mm) are shown below.

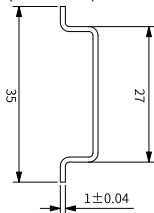

**Caution**

When installed on a DIN rail other than the recommended one (especially the one whose thickness is not 1.0 mm), the product will not fit in place as the mounting hook does not work.

## ■ Installing the modules to each other

You can install multiple modules to each other with the help of top and bottom guides on the modules, as shown below.

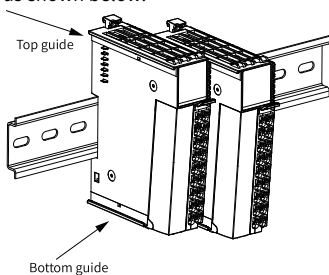

## ■ Installing the module onto DIN rail

1. Align the module with the DIN rail and push the module in the direction indicated by the arrow until you hear a clicking sound, as shown below.

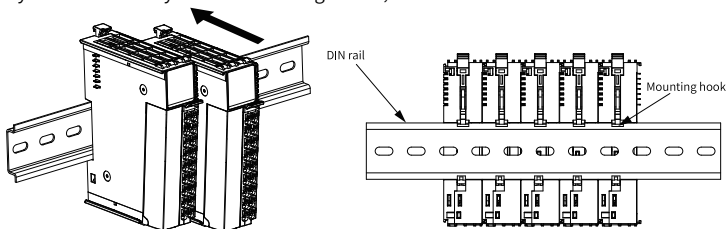

2. Make sure the DIN rail mounting hook of the module is locked. The locked and unlocked states of the mounting hook are shown below.

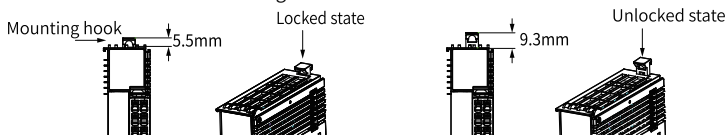

- If the mounting hook is pressed down, it is locked.
- If the mounting hook is lifted up, it is unlocked.

Press down the mounting hook to lock the module to the DIN rail.



When the module is not installed on the rail, keep the mounting hook in the locked state. Keeping the mounting hook unlocked for a prolonged time may cause the hook to fail.

3. Mount an end plate on either side of the PLC or the module.

To mount the end plate, hook the bottom of it to the bottom of the DIN rail, rotate the end plate to hook the top of it to the top of the DIN rail, and then tighten the screw to lock the end plate in place.

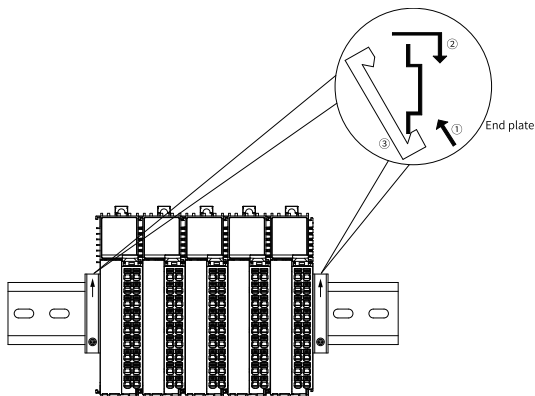

### ■ Removing the module

Pry the DIN rail mounting hook upwards with a tool such as slotted screwdriver, hold the protrusions and pull the module out straight forward, and then press down the top of the DIN rail mounting hook.

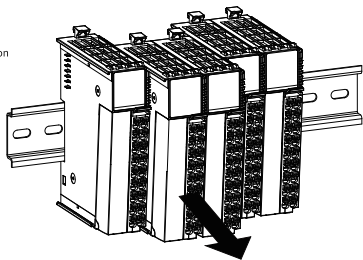
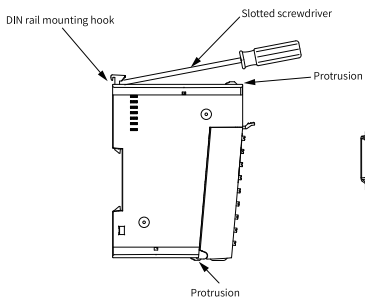

# 3 Electrical Installation

## 3.1 Cable Selection

The cable lug and cable diameter included in the following table are only for reference.

Material Name	Cable Diameter		KST		Suzhou Yuanli	
	mm <sup>2</sup>	AWG	Model	Crimping Tool	Model	Crimping Tool
Tubular lug	0.3	22	E0308	KST2000L	0308	YAC-5
	0.5	20	E0508		0508	
	0.75	18	E7508		7508	
	1.0	18	E1008		1008	
	1.5	16	E1508		1508	

If you use other types of tubular lug, crimp the lug to the cables according to the shape and dimension requirements shown in the figure below.

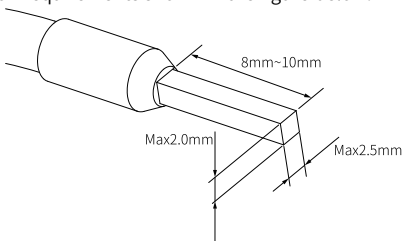

## 3.2 Terminal Definitions

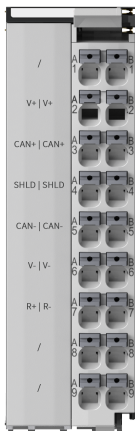

Left Signal	Left Terminal	Right Terminal	Right Signal
-	A1	B1	-
V+	A2	B2	V+
CAN+	A3	B3	CAN+
SHLD	A4	B4	SHLD
CAN-	A5	B5	CAN-
V-	A6	B6	V-
R+	A7	B7	R-
-	A8	B8	-
-	A9	B9	-

## 3.3 Terminal Wiring

The CAN/DeviceNet communication bus is a two-bus system, and all devices are connected to the bus system in parallel. Connect a 120  $\Omega$  termination resistor at either end of the bus to prevent signal reflection. The CAN/DeviceNet communication topology is shown below.

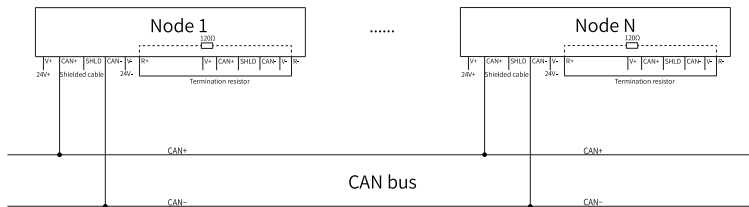

It is recommended to use the 5-core shielded cable for the DeviceNet communication. The V+ and V- terminals are connected to the power supply (11 VDC to 25 VDC), the CAN+ and CAN- terminals are connected to the differential signal cable, the SHLD is connected to the shielded cable, and the R+ and R- terminals are shorted to the termination resistor.

## Note

The V+, CAN+, SHLD, CAN-, and V- terminals on the left side are interconnected with the corresponding terminals on the right side. Therefore, you can connect the terminals on either side.

## 4 Programming Examples

As an example, the following describes how to connect the AC702 master controller to the DeviceNet master (GL20-1DNM) and the DeviceNet slaves (set to the auto-loop mode) via the GL20-RTU-ECT32 communication interface module to configure, send, and receive data.

1. Enable AC702 as EtherCAT master and add the GL20-RTU-ECT32 module.

- In the **Devices** pane, double-click **Network Configuration**, then check the "EtherCAT Master" corresponding to the PLC to which the GL20-RTU-ECT32 module is connected.

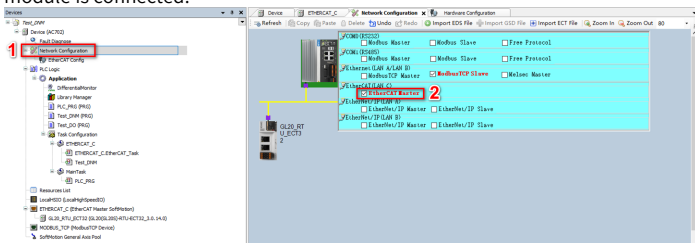

- In the **Network Device List** pane, double click **GL20-RTU-ECT32\_x.x.x.x**, or drag it to the **Network Configuration** page, to add the GL20-RTU-ECT32 communication interface module.



2. Add a GL20-1DNM DeviceNet master module.

- Adding the module via device scanning

- a. In the **Devices** pane, right-click **ETHERCAT\_x (EtherCAT Master SoftMotion)** and select **Scan Devices**. The **Scan Devices** dialog pops up.

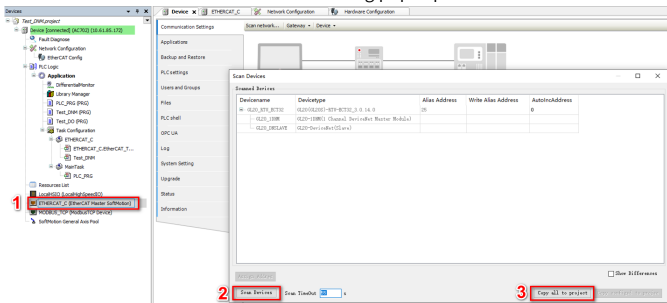

- b. Click **Scan Devices**. The scanned GL20-1DNM module will be displayed in the list. Then click **Copy all to project** to finish adding the module.

- Adding the module manually

In the **Devices** pane, double-click **EtherCAT Config**. In the **In\Output Module List** pane, double-click **GL20-1DNMASTER** or drag it to the **Hardware Configuration** page to add the GL20-1DNM module.

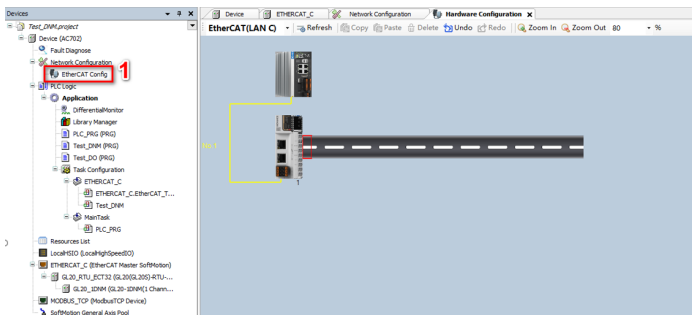

3. Configure the GL20-1DNM DeviceNet master module.

- a. In the **Devices** pane, double-click **GL20-DNMMaster**. The configuration page of GL20-DNMMaster opens.

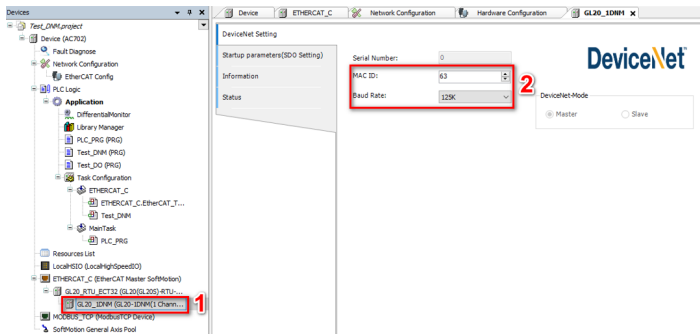

Parameter	Description
MAC ID	<p>Unique physical address of the module.</p> <p>The MAC ID is assigned according to the plan and must not be duplicate.</p> <p>Value range: 0 to 63.</p> <p>Default: 63</p>
Baud rate	<p>Subject to actual conditions.</p> <p>Value range: 125k, 250k, and 500k</p> <p>Default: 125k</p>

b. Configure the MAC ID and baud rate of the DeviceNet master.

#### 4. Add a virtual DeviceNet master.

The GL20-1DNM module needs to be used with a virtual DeviceNet master.

- a. In the **Devices** pane, right-click **Device (AC702)** and select **Add Virtual Device**. The **Insert Device** dialog pops up.

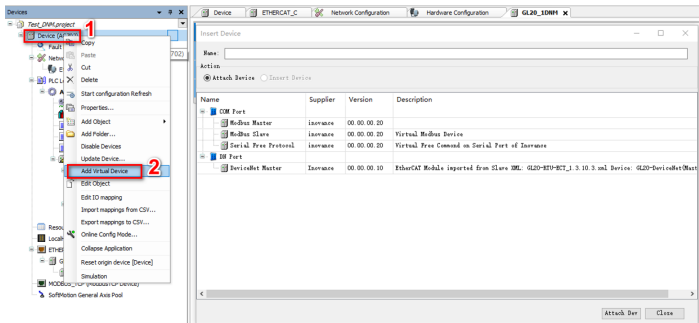

- b. Click **DeviceNet Master**, and then click **Attach Dev**.

After the addition is completed, a "DeviceNet Master\_Virtual" node will be created in the **Devices** pane.

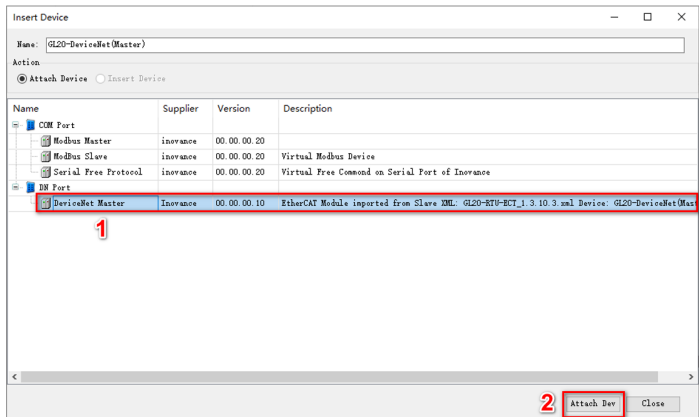

- c. In the **Devices** pane, double-click **DeviceNet Master\_Virtual**. In the **Settings** tab, select the actual DeviceNet master from the **EtherCAT device** drop-down list.

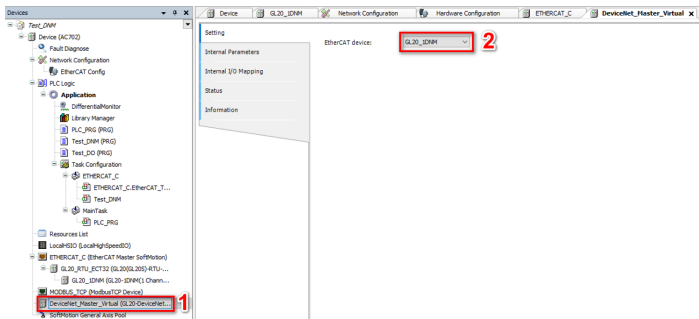

## 5. Add a DeviceNet slave module.

After adding the virtual DeviceNet master, add a DeviceNet slave module to complete the DeviceNet network configuration.

### a. (Optional) Import the EDS file of the DeviceNet slave.

To add a third-party DeviceNet slave, it is needed to import its EDS file.

- 1). Select **Tools > Device Repository** in the menu bar. The **Device Repository** dialog pops up.

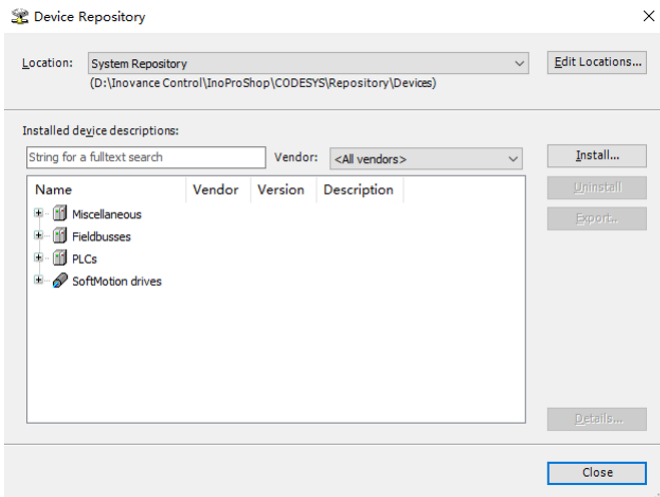

- 2). Click **Install**. In the pop-up dialog, select the EDS file of the third-party DeviceNet slave and then click **Open**.

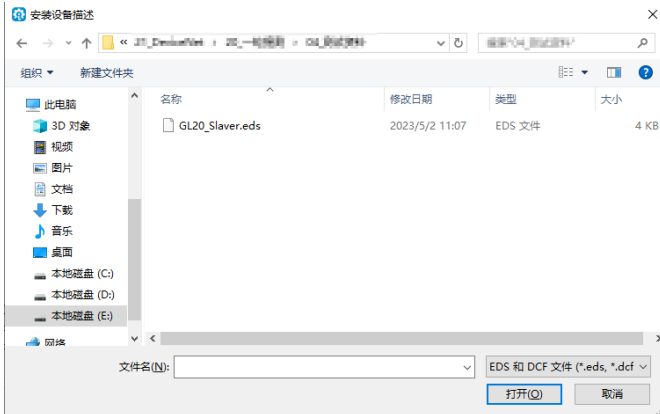

After installation, you can see the DeviceNet slave module.

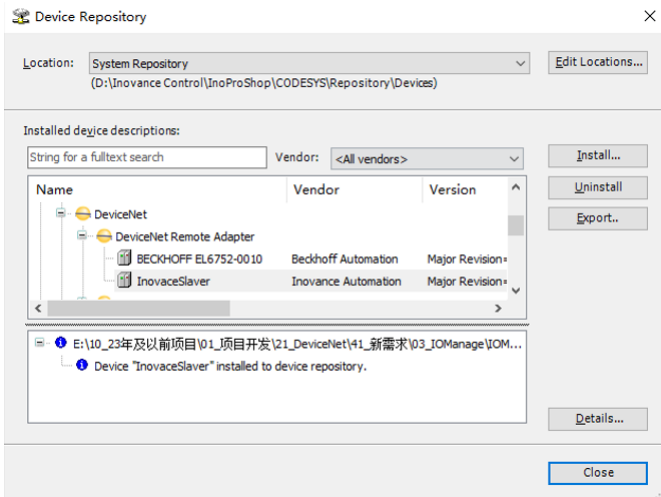

b. Add a DeviceNet slave module manually or via device scanning.

- Adding the module via device scanning



## Caution

If you want to add the DeviceNet slaves through scanning, you need to download the compiled program to the PLC before scanning.

- 1). In the **Devices** pane, right-click **DeviceNet Master\_Virtual** and select **Scan Devices**. The **Scan Devices** dialog pops up.

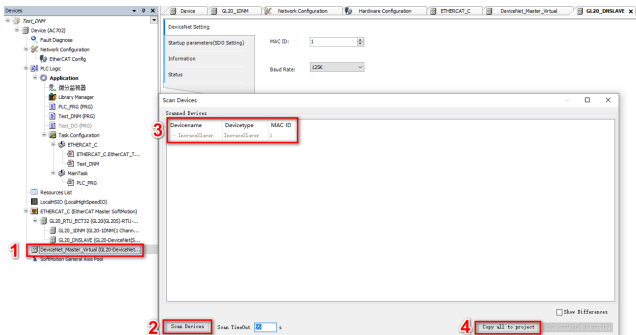

- 2). Click **Scan Devices**. After the scan is complete, the DeviceNet slave device will be displayed.



## Caution

The scanned slaves are ordered according to the MAC ID from the smallest to the largest, which may not be consistent with the order of the actual mounted DeviceNet slaves.

- 3). Select the DeviceNet slave device and click **Copy all to project** to finish adding the DeviceNet slave module.
- Adding the module manually
- 1). In the **Devices** pane, right-click **DeviceNet Master\_Virtual** and select **Add Device**. The **Add Device** dialog pops up.

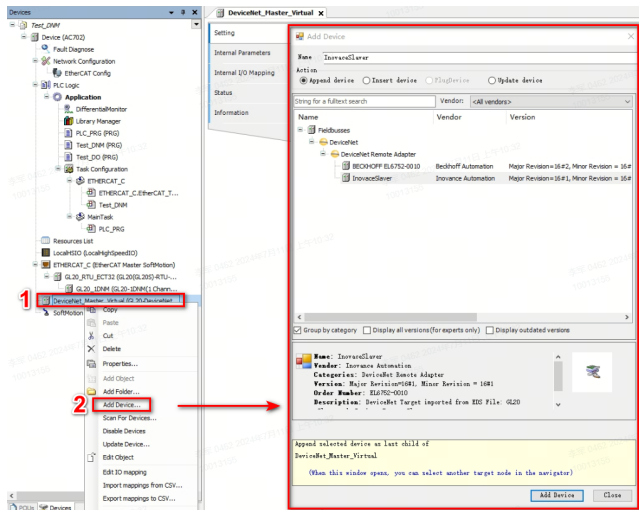

- 2). If there is no EDS file of the DeviceNet slave, click **InovanceSlaver** directly to configure the device. Click **Add Device** to add a corresponding number of DeviceNet slaves according to the actual mounted devices.

**Add Device** [X]

Name:

Action:  Append device  Insert device  PlugDevice  Update device

String for a fulltext search:  Vendor: <All vendors>

Name	Vendor	Version
Fieldbusses		
DeviceNet		
DeviceNet Remote Adapter		
BECKHOFF EL6752-0010	Beckhoff Automation	Major Revision=16#2, Minor Revision = 16#
<b>InovaceSlaver</b>	Inovance Automation	Major Revision=16#1, Minor Revision = 16#

1

Group by category  Display all versions (for experts only)  Display outdated versions

---

**Name:** InovaceSlaver  
**Vendor:** Inovance Automation  
**Categories:** DeviceNet Remote Adapter  
**Version:** Major Revision=16#1, Minor Revision = 16#1  
**Order Number:** EL6752-0010  
**Description:** DeviceNet Target imported from EDS File: GL20

---

Append selected device as last child of  
 DeviceNet\_Master\_Virtual

(When this window opens, you can select another target node in the navigator)

2

## 6. Configure the DeviceNet slave module.

- a. In the **Devices** pane, double-click the DeviceNet slave module and configure the MAC ID and Cycle Time of the DeviceNet slave according to the following table.

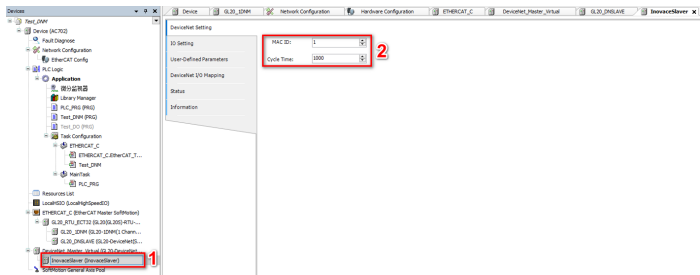

Parameter	Description
MAC ID	<p>Unique physical address of the module.</p> <p>The MAC ID is assigned according to the plan and must not be duplicate.</p> <p>Value range: 0 to 63.</p> <p>Default: 1</p>
Cycle time (ms)	<p>Subject to actual conditions.</p> <p>Value range: 200 to 2000.</p> <p>Default: 1000</p>

b. Click the **IO Setting** tab, and then click the **Add** button in the "Input: xx- byte" and "Output: xx- byte" panes respectively to add input/output data bytes of each DeviceNet slave as needed.

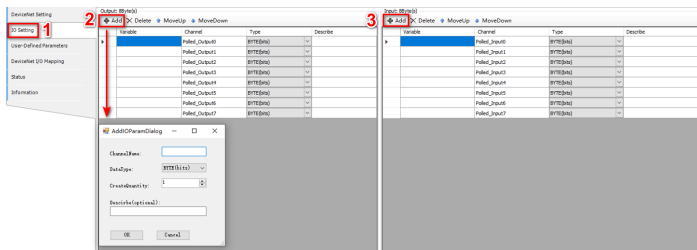

You can add different types of variables and implement batch addition. Each DeviceNet slave supports up to 255 bytes for input and output respectively, and the DeviceNet master supports up to 960 bytes for input and output respectively.

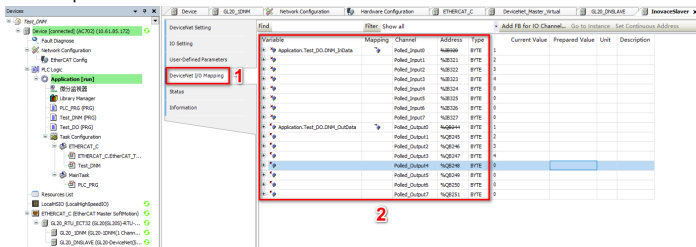

c. Click the **DeviceNet I/O Mapping** tab. In the **Variable** column, map the input and output data.



7. After successful compiling, download the project and run it to verify the self-loop function of data sending and receiving.

a. Click the    icons in the toolbar to check, compile, and download the program.

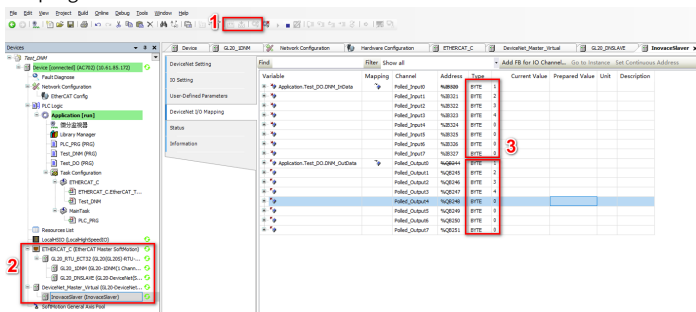

b. Ensure that the DeviceNet network is running properly.

- Method 1: In part 2 of the above figure, the icon  before the GL20 modules and virtual DeviceNet modules indicates that the DeviceNet network is running properly.
- Method 2: When the value of "LBus status" in the **EtherCAT I/O Mapping** tab is "8" and the value of "MasterState" in the **Internal I/O Mapping** tab is "5", the DeviceNet network is running properly.

Variable	Mapping	Channel	Address	Type	Current Value	Prepared Value	Unit	Description
Ibus status		NDR1	IBYTE					Ibus status
...	...	...	...	...	...	...	...	...

Variable	Mapp...	Channel	Address	Type	Current Value	Prepared Value	Unit	Descr...
MasterState		NDR1	IBYTE		0			
SlaveState		NDR16	ARRAY					
...	...	...	...	...	...	...	...	...

c. Observe whether the output data (sent data) is consistent with the input data (received data).

If the data is consistent, the self-loop function of data sending and receiving is successful.

## 5 Fault Diagnosis

### ■ Diagnosis via LED indicators

MS indicator		NS indicator		Meaning	Solution
Red	Green	Red	Green		
OFF	Steady ON	OFF	Blinking	The DeviceNet communication bus is not configured with a slave.	Configure a slave on the DeviceNet communication bus.
		Blinking	Steady ON	A slave on the DeviceNet communication bus is disconnected.	<ol style="list-style-type: none"> <li>1. Check whether the communication between DeviceNet master and slave is normal.</li> <li>2. Check that the DeviceNet slave is working properly.</li> </ol>
				The CAN node enters the BusOff state and disconnects from CAN bus.	The CAN bus generates Busoff. Check that the CAN bus cable is in good contact with the terminals and that a termination resistor is connected (Under normal circumstances, it is necessary to connect a termination resistor. A short connection between the R+ and R- terminals indicates that a termination resistor is connected. If R+ and R- terminals and termination resistor are damaged, you can connect an external termination resistor.)

MS indicator		NS indicator		Meaning	Solution
Red	Green	Red	Green		
Steady ON	OFF	Steady ON	OFF	EtherCAT communication bus is not connected.	Check that the EtherCAT cable is connected normally.
				The module is not connected to the 24 V power.	Check that the V+ and V- terminals are connected normally.
				MAC ID conflict	Check that the MAC ID of the module is not duplicate with the MAC ID of the DeviceNet slave.
Flashing red and green alternatively		Flashing red and green alternatively		The module is acquiring the configuration information.	Check that the PLC and the GL20-RTU-ECT32 are running normally.
				The module fails to receive the DeviceNet slave configuration data.	Reconfigure the module.

## ■ Diagnosis via object dictionary

When the ERR indicator of the module is ON, it indicates that the module encounters a fault. The module reports a fault code. You can get the fault code through the diagnostic data object dictionary value displayed on the "CoE Online" interface, as shown below.

The screenshot shows the SIMATIC Manager interface with the 'Information' table expanded. The table contains the following data:

Index/Subindex	Name	Flags	Type	Value
* 16#3011:16#00	Port 1 error counter	RO	USINT	4
* 16#3012:16#00	ESC error counter	RO	USINT	4
* 16#3016:16#00	Station address	RO	USINT	4
16#3020:16#00	Fpga softv version	RO	UDINT	66561
* 16#3021:16#00	Module software version	RO	USINT	4
* 16#5000:16#00	Disable Slot Control	RW	USINT	4
16#5001:16#00	Disable Function Control	RW	USINT	0
* 16#8000:16#00	DNMaster setp0	RW	USINT	15
* 16#8001:16#00	DNMaster setp1	RW	USINT	15
* 16#8040:16#00	DNSlave setp0	RW	USINT	15
* 16#8041:16#00	DNMaster setp1	RW	USINT	15
* 16#A000:16#00	DeviceNet Master module Diagnosis information	RO	USINT	15
-16#01	Module Err	RD	UINT	0
-16#02	Offline Number	RD	UINT	0
-16#03	Slave Offline_1_Flag	RD	UINT	0
-16#04	Slave Offline_2_Flag	RD	UINT	0
-16#05	Slave Offline_3_Flag	RD	UINT	0
-16#06	Slave Offline_4_Flag	RD	UINT	0
-16#07	DNMaster Status	RD	UINT	0
-16#08	DNSlave Station	RD	UINT	0
-16#09	DNSlave ErrCode	RD	UINT	0
-16#0A	CANRec Frame Count	RD	UINT	738
-16#0B	REC Err Count	RD	UINT	0
-16#0C	TEC Err Count	RD	UINT	0
-16#0D	CAN BUS-OFF Count	RD	UINT	0
-16#0E	CAN LoadRate	RD	UINT	0
-16#0F	Reserved_0	RD	UINT	0
* 16#A040:16#00	DeviceNet Slaver module Diagnosis information	RO	USINT	14
* 16#F000:16#00	Modular device profile	RO	USINT	2
* 16#F030:16#00	Configured Module Ident List	RO	USINT	2

For the module installed in slot n (n=1-32), the object dictionary definition for index 0xA000+0x40\*(n-1) is shown in the table below.

0xA000+0x40*(n-1): Diagnostic Information					
Sub-index	Name	Data type	Access mode	Mapping	Default
0	Fault code	USINT	RO	NO	F
1	Fault information	UINT	RO	NO	0
2	Number of offline DeviceNet slaves	UINT	RO	NO	0
3	Offline flag of DeviceNet slaves #0 to #15. Each bit represents one slave, and bit8 represents slave #8.	UINT	RO	NO	0
4	Offline flag of DeviceNet slaves #16 to #31. Each bit represents one slave, and bit8 represents slave #24.	UINT	RO	NO	0

Index	0xA000+0x40*(n-1): Diagnostic Information				
Sub-index	Name	Data type	Access mode	Mapping	Default
5	Offline flag of DeviceNet slaves #32 to #47. Each bit represents one slave, and bit8 represents slave #40.	UINT	RO	NO	0
6	Offline flag of DeviceNet slaves #48 to #63. Each bit represents one slave, and bit8 represents slave #56.	UINT	RO	NO	0
7	State of state machine of DeviceNet slave	UINT	RO	NO	0
8	DeviceNet slave number	UINT	RO	NO	0
9	DeviceNet slave fault code	UINT	RO	NO	0
A	CAN frame RX count	UINT	RO	NO	0
B	RX error count	UINT	RO	NO	0
C	TX error count	UINT	RO	NO	0
D	Bus disconnection count	UINT	RO	NO	0
E	Bus load rate	UINT	RO	NO	0
F	Reserved	UINT	RO	NO	0

### ● Module fault code

Fault code	Fault description	Solution
0x5003	External 24 V power failure	Check the isolated power supply of the module

### ● State of state machine of DeviceNet slave

Status code	Meaning
0	Operation
2	Slave initialization
4	Master initialization
5	Duplicate name detection
6	Fault

● **Network fault code**

Fault code	Fault description	Solution
0x0000	DeviceNet slave online	-
0x0001	No DeviceNet slave is connected to the module (DeviceNet master).	Check the configuration or the physical wiring of the DeviceNet network.
0x0002	DeviceNet slave fails to establish communication with the module (DeviceNet master).	Check the configuration or the physical wiring of the DeviceNet network.
0x0003	The MAC ID of the DeviceNet slave conflicts with the MAC ID of the module (DeviceNet master).	Check the MAC ID of the DeviceNet slave.
0x0004	The length of data to be received by the DeviceNet slave as configured on the DeviceNet master is inconsistent with the length of data received by the actual mounted DeviceNet slave.	Check the configured received data length based on the number of the faulty slave.
0x0008	The length of data to be sent by the DeviceNet slave as configured on the DeviceNet master is inconsistent with the length of data sent by the actual mounted DeviceNet slave.	Check the configured sent data length based on the number of the faulty slave.

## 6 Appendix: Version Matching Information

You can get the firmware of module and the firmware of communication interface module from Inovance technical support, and get XML file and InoProShop from <https://www.inovance.com>. The following table describes the version matching information.

Module Firmware Version	Communication Interface Module Firmware Version	XML File Version	InoProShop Version
Board software: 1.2.1.0 and above	GL20-RTU-ECT32: Board software 2.5.9.2 and above	GL20-RTU-ECT32: 3.0.3.0 and above	V1.8.0 and above