



GS20-IOL-8ADH Series Analog Input Module User Guide



Industrial
Automation



New Energy
Vehicle



Intelligent
Elevator



Intelligent
Robot



Digital
Energy



Rail
Transit



Data code PS00021555A01

Legal Information

Copyright

Copyright © 2025 Shenzhen Inovance Technology Co., Ltd. All rights reserved.

This documentation is the exclusive property of Shenzhen Inovance Technology Co., Ltd. No individual or entity may excerpt, reproduce, modify, translate, or distribute any content herein without written consent from Inovance.

Legal action will be taken against infringement.

Trademarks

INOVANCE is a registered trademark of Shenzhen Inovance Technology Co., Ltd. and its affiliates. All other trademarks or registered trademarks mentioned in this documentation are the property of their respective owners. Unauthorized use of these trademarks by third parties for any purpose without written authorization could violate the rights of their owners.

Disclaimer of Liability

Due to continuous updates and improvements of products and technologies, the content of this documentation may not fully match the actual products. In the event of any discrepancies, the actual products shall prevail.

The contents are subject to change without notice due to product upgrade.

Waste Disposal

The storage, use, and disposal of this product (including optional accessories) must comply with local laws and regulations.

Qualified Personnel

The product/system described in this documentation may be operated only by personnel qualified for the specific task in accordance with the relevant documentation, in particular its warning notices and safety instructions. Qualified personnel can identify the risks of the product/system and prevent possible dangers.

Proper Use of the Product

Proper transportation, storage, assembly, installation, commissioning, operation, and maintenance are required to ensure the safe operation of the product without any problems. The required ambient conditions must be met. All operations must follow the guidelines provided in this documentation.

Preface

Introduction

GS20-IOL-8ADH 8-channel analog input slave module supports voltage and current input modes, with a resolution of up to 16 bits. It can be used with an IO-Link master.

This guide describes the product information, mechanical installation, electrical installation, and commissioning of the product.

Standard

The following table lists the certifications, directives, and standards that the product may comply with. For details about the acquired certificates, see the certification marks on the product nameplate.

Certification	Directive		Standard
CE certification	EMC directive	2014/30/EU	24 VDC products: EN 61131-2 220 VAC products: EN 61131-2 EN 61000-3-2 EN 61000-3-3
	LVD directive	2014/35/EU	EN 61010-1 EN 61010-2-201
	RoHS directive	2011/65/EU amended by (EU)2015/863	EN IEC 63000
UL/cUL certification	-		UL 61010-1 UL 61010-2-201 CAN/CSA-C22.2 No. 61010-1 CSA C22.2 NO. 61010-2-201
KCC certification	-		-
EAC certification	-		-
UKCA certification	Safety regulations	Electrical Equipment (Safety) Regulations 2016	EN 61010-1 EN 61010-2-201
	EMC regulations	Electromagnetic Compatibility Regulations 2016	24 VDC products: EN 61131-2 220 VAC products: EN 61131-2 EN 61000-3-2 EN 61000-3-3
	RoHS regulations	Directive (RoHS) Regulations 2012	EN IEC 63000

More documents

Document	Code	Description
GS20-EIP-8L Series High Protection IO-Link Master Module User Guide	PS00007354	Introduces the product information, mechanical installation, electrical installation, programming commissioning, and troubleshooting of the product.
GS20-ECT-8L-INT Series High Protection IO-Link Master Module User Guide	PS00016635	Introduces the product information, mechanical installation, electrical installation, programming commissioning, and troubleshooting of the product.
GS20-IOL-8ADH Series Analog Input Module User Guide (This guide)	PS00021555	Introduces the mechanical installation, electrical installation, and program commissioning of the product.

Revision history

Date	Version	Revision
April 2026	A01	Updated the "General Safety Instructions" section.
September 2025	A00	Initial release.

Access to the guide

This guide is not delivered with the product. You can download the PDF version in the following ways:

- Visit <https://www.inovance.com/global>, and choose Service&Support > Support > Documentation Download.
- Scan the QR code on the product with your smart phone.
- Scan the QR code below to install My Inovance app, where you can search for and download the guide.



Warranty

Inovance provides warranty service within the warranty period (as specified in your order) for any fault or damage that is caused by proper operation of the user. Maintenance will be charged after the warranty expires.

Even within the warranty period, maintenance can be charged for the following product damage:

- Damage caused by operations not following the instructions in the guide
- Damage caused by fire, flood, or abnormal voltage
- Damage caused by using the product for unintended functions
- Damage caused by using the product outside the specified scope
- Secondary damage caused by force majeure (natural disaster, earthquake, lightning strike)

When applicable, relevant maintenance fee will be charged according to the latest Price List of Inovance. If otherwise agreed upon, the agreed terms and conditions shall prevail.

For details, see the Warranty Card.

1 General Safety Rules

1.1 General Safety Instructions

Safety disclaimer

1. Read through the safety instructions before installing, operating, and servicing the equipment, and comply with these instructions.
2. To ensure personal and equipment safety, observe the notes indicated on the product labels and all the safety instructions in the user guide.
3. The "CAUTION", "WARNING", and "DANGER" are only supplements to the safety instructions.
4. Use this product according to the designated environment requirements. Damage caused by improper use is not covered by warranty.
5. Inovance shall take no responsibility for any personal injury or property damage caused by improper use.

Safety levels and definitions



DANGER

The "DANGER" sign indicates that failure to comply with the notice will result in severe personal injuries or even death.



WARNING

The "WARNING" sign indicates that failure to comply with the notice may result in severe personal injuries or even death.



CAUTION

The "CAUTION" sign indicates that failure to comply with the notice may result in minor or moderate personal injury or equipment damage.

Unpacking







WARNING



- Do not install the product in the case of any damage, rust, or signs of use on the product or accessories upon unpacking.
- Do not install the product in the case of water seepage into the product or missing or damaged components upon unpacking.
- Do not install the product in the case of any discrepancy between the product you received and the product name on the packing list.



CAUTION

- Check whether the packing is intact and whether there is damage, water seepage, dampness, and deformation before unpacking.
- Unpack the package by following the unpacking sequence. Do not strike the package violently.
- Check for damage, rust, or scratches on the surfaces of the product and accessories upon unpacking.
- Check whether the package contents are consistent with the packing list after unpacking.

Storage and transportation	
 WARNING	<ul style="list-style-type: none">• Large-scale or heavy equipment must be transported by qualified professionals using specialized hoisting equipment. Failure to comply may result in personal injury or equipment damage.• Before hoisting the equipment, ensure that components such as the front cover and terminal blocks are secured firmly with screws. Loosely-connected components may fall off and result in personal injury or equipment damage.• Never stand or stay below the product which is being hoisted.• Hoist the equipment at a constant speed with a steel rope to prevent any vibration or shock to the equipment. Never turn the equipment over or keep it suspended for a long time. Failure to comply may result in personal injury or equipment damage.
 CAUTION	<ul style="list-style-type: none">• Handle the equipment with care and mind your steps during transportation to prevent personal injury or equipment damage.• When carrying the equipment with bare hands, hold the enclosure firmly with care to prevent parts from falling. Failure to comply may result in personal injury.• Store and transport the equipment based on the storage and transportation requirements. Failure to comply may result in equipment damage.• Do not store or transport the equipment in equipment exposed to splashing water or rain, direct sunlight, strong electric field, strong magnetic field, or strong vibration.• Do not store the equipment for more than three months. Long-term storage requires stricter protection and necessary inspections.• Pack the equipment securely and properly before transportation. Use a sealed container for long-distance transportation.• Do not transport the equipment with other devices or materials that may harm or have negative impacts on the equipment.
Design	
 DANGER	<ul style="list-style-type: none">• Design a safety circuit and add an error handling program in the software to ensure the product remains in a safe state upon external power failure or product faults.• Add an external safety device such as a fuse or circuit breaker because the equipment may smoke or burn due to long-time overcurrent caused by a rating error or short-circuited load.
 WARNING	<ul style="list-style-type: none">• When an output unit such as a relay or transistor in the equipment is damaged, the output may become uncontrollable and remain ON or OFF for a long period.• The equipment design must comply with the overvoltage category requirements specified in the environmental specifications. The power supply must have a system-level lightning protection device, assuring that overvoltage due to lightning shock cannot be applied to the power supply input terminals, signal input terminals, or output terminals, to prevent equipment damage.• Make sure that proper measures have been taken to avoid malfunction caused by the communication faults between the equipment and related devices, preventing personal injury or equipment damage.
 CAUTION	<p>Do not create, on the touch screen of the HMI, switches that may result in personal injury of the operator or equipment damage. Use independent switches for performing critical operations. Failure to comply may result in accidents caused by wrong outputs or faults.</p>

Installation	
 DANGER	The equipment must be operated only by professionals with electrical knowledge. Non-professionals are not allowed.
 WARNING	<ul style="list-style-type: none">• Read through the guide and safety instructions before installation.• Do not install this equipment in places with strong electric or magnetic field.• Before installation, ensure that the mechanical strength of the installation site can bear the weight of the equipment. Failure to comply will result in mechanical hazards.• Before installation, ensure that the installation environment meets the specifications. Failure to comply will result in product damage.• Do not wear loose clothes or accessories during installation. Failure to comply may result in an electric shock.• Before installing the equipment in an enclosed environment (such as a cabinet or case), use a cooling device (such as a fan or air conditioner) to cool the environment to the required temperature. Failure to comply may result in equipment over-temperature or a fire.• Do not retrofit the equipment.• Do not fiddle with the bolts used to fix equipment components or the bolts marked in red.• The equipment shall be installed in a cabinet or terminal device. Protection measures such as a fireproofing shell, electric protection shell, or mechanical protection shell must be provided for the cabinet or terminal device. The IP level must meet IEC standards and local laws and regulations.• Before installing devices with strong electromagnetic interference, such as a transformer, install a shielding device for the equipment to prevent malfunction.• Install the equipment onto an incombustible object such as a metal. Keep the equipment away from combustible objects. Failure to comply may result in a fire.• For any equipment not supporting hot swapping, disconnect all external power supplies of the system before installing/disassembling the equipment. Failure to comply may result in an electric shock or equipment fault or malfunction.
 CAUTION	<ul style="list-style-type: none">• Cover the top of the equipment with a piece of cloth or paper during installation. This is to prevent unwanted objects such as metal chippings, oil, and water from falling into the equipment and causing faults. After installation, remove the covering to prevent it from blocking the vent, which may affect the heat dissipation and cause the equipment to overheat.• During installation, ensure the equipment is connected to the respective connector securely and hook the equipment firmly. Improper installation may result in malfunction, fault, or fall-off.

Wiring



- The equipment must be operated only by professionals with electrical knowledge. Non-professionals are not allowed.
- Before wiring, cut off all the power supplies of the equipment. Wait for at least the time designated on the equipment warning label before further operations because residual voltage still exists after power-off. Measure the DC voltage of the main circuit and make sure that it is below the safety voltage. Failure to comply may result in an electric shock.
- Do not perform wiring, remove the equipment cover, or touch the circuit board with power-on. Failure to comply may result in an electric shock.
- Make sure that the equipment is grounded properly. Failure to comply may result in an electric shock. Separate grounding or single-point grounding, other than common grounding, is recommended.

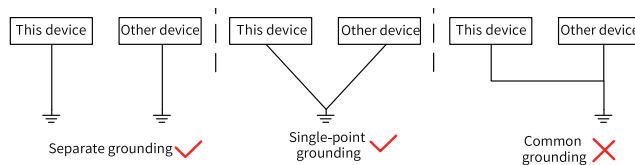

- Insulate the cable terminals properly to ensure the insulation distance between cables will not be shortened after cables are connected to the terminal block. Failure to comply may result in an electric shock or equipment damage.
- Install the terminal cover attached to the equipment before power-on or operation after wiring is done. Failure to comply may result in an electric shock.



- Do not connect the power cable to output terminals of the equipment or product. Failure to comply may cause equipment damage or even a fire.
- Cables must meet size and shield requirements. The shield must be reliably grounded at one end.
- Fix the terminal screws with the tightening torque specified in the guide. Improper tightening torque may cause the connecting part over-temperature or damage, resulting in a fire.
- After wiring is done, check that all cables are connected properly and no screws, washers or exposed cables are left inside the equipment. Failure to comply may result in electric shock or equipment damage.













- Follow the proper electrostatic discharge (ESD) procedure and wear an anti-static wrist strap to perform wiring. Failure to comply may result in damage to the equipment or to the internal circuit of the product.
- Use shielded twisted pairs for the control circuit. Connect the shield to the grounding terminal of the equipment for grounding purpose. Failure to comply will result in equipment malfunction.

Power-on



- The equipment must be operated only by professionals with electrical knowledge. Non-professionals are not allowed.
- Before power-on, check that the equipment is installed and wired properly.
- Before power-on, make sure that the power supply meets equipment requirements to prevent equipment damage or even a fire.
- Do not open the cabinet door or protective cover of the equipment, touch any terminal of the equipment, or remove any part of the equipment with power-on. Failure to comply may result in death or personal injury.

Power-on	
 WARNING	<p>Perform a trial run after wiring to ensure that the equipment operates safely. Failure to comply may result in personal injury or equipment damage.</p>
Operation	
 DANGER	<ul style="list-style-type: none"> • The equipment must be operated only by professionals. Failure to comply can result in death or personal injury. • Do not touch any connecting terminals or disassemble any unit or component of the equipment during operation. Failure to comply may result in an electric shock.
 WARNING	<ul style="list-style-type: none"> • Do not touch the enclosure, fan, or resistor with bare hands. Failure to comply may result in burns. • Prevent metal or other objects from falling into the equipment during operation. Failure to comply may result in a fire or equipment damage. • During operation, do not bring live parts into contact with the metal enclosure of the product. Failure to comply may result in a fire or equipment damage.
 CAUTION	<ul style="list-style-type: none"> • Operate the equipment under the required environmental conditions. Failure to comply may result in equipment fault or damage. • Touch the HMI panel with hands only during operation. Inovance assumes no responsibility for panel damage caused by excessive external force. <p>Safety recommendations</p> <ul style="list-style-type: none"> • In positions where the operator directly touches the mechanical parts, for example, where a mechanical device is loaded/unloaded, or where a machine runs automatically, manually-operated devices or other alternative means must be carefully designed so that they are independent of the equipment to start or stop the automatic operation of the system. • If you need to modify the program while the system is running, use the lock function or other protection measures to ensure that only authorized personnel can make the necessary modifications.
Battery usage	
 WARNING	<ul style="list-style-type: none"> • Do not use batteries that do not meet the equipment requirements. Failure to comply may result in death, personal injury, explosion, or a fire. • Do not throw batteries into a fire or heat oven. Do not crush or cut batteries. Failure to comply may result in death, personal injury, explosion, or a fire. • Do not expose batteries to extremely high temperatures. Failure to comply may result in death, personal injury, explosion, or a fire. • Do not swallow batteries. Failure to comply may result in chemical burns. • If a button battery is swallowed by accident, seek medical treatment immediately. Failure to comply may result in severe internal burns within two hours, which may cause death.
 CAUTION	<ul style="list-style-type: none"> • Keep the batteries away from children. • If the battery compartment is not shut tight, stop using the product and keep it away from children.

Maintenance
<p> DANGER</p> <ul style="list-style-type: none"> • Maintenance must be carried out by professionals who have received electrical trainings and have sufficient electrical knowledge. • Do not maintain the equipment with power-on. Failure to comply may result in an electric shock. • Before maintenance, disconnect all the power supplies of the equipment and wait for at least the time specified on the warning label. • Disconnect all external power supplies of the system before cleaning the equipment or re-tightening screws on the terminal block or screws for connector installation. Failure to comply may result in an electric shock. • Disconnect all external power supplies of the system before removing the equipment or connecting/removing wiring. Failure to comply may result in an electric shock or malfunction.
<p> WARNING</p> <p>Perform routine and periodic inspection and maintenance on the equipment according to maintenance requirements and keep a maintenance record.</p>
Repair
<p> DANGER</p> <ul style="list-style-type: none"> • Repair must be carried out by professionals who have received the electrical trainings and have sufficient electrical knowledge. • Do not repair the equipment with power-on. Failure to comply may result in electric shock. • Before inspection or repair, disconnect all the power supplies of the equipment and wait for at least the time specified on the warning label.
<p> WARNING</p> <ul style="list-style-type: none"> • Submit the repair request according to the warranty agreement. • When the fuse is blown or the circuit breaker or earth leakage circuit breaker (ELCB) trips, wait as specified on the product warning sign before power-on or further operations. Failure to comply may result in personal injuries, equipment damage or even death. • When the equipment is faulty or damaged, require professionals to perform troubleshooting and repair by following repair instructions and keep a repair record. • Replace quick-wear parts of the product in accordance with the replacement instructions. • Do not operate the damaged equipment. Failure to comply may result in death, personal injury, or severe equipment damage. • Recheck the wiring and reset the parameters after equipment replacement.
Disposal
<p> WARNING</p> <ul style="list-style-type: none"> • Dispose of retired equipment in accordance with local regulations and standards. Failure to comply may result in death, personal injury, or property damage. • Recycle retired equipment in accordance with industry waste disposal standards to avoid environmental pollution. • Treat the scrapped equipment as industrial waste. Dispose of the batteries according to local laws and regulations.

Safety labels

To ensure safe operation, comply with safety labels on the equipment and do not damage or remove the labels. The following table describes the meaning of the safety labels.

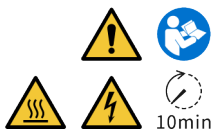
Safety labels	Description
	<ul style="list-style-type: none"> • Before using the equipment, read the guide and safety precautions carefully. Failure to comply may result in personal injury, death, or equipment damage. • Do not touch the terminals or remove the cover with power-on or within 10 min after power-off. Failure to comply may result in an electric shock. • The surface of the product may become very hot during operation. Do not touch these hot areas, as this may cause burns!

1.2 Industrial Information Security

The product provides an interface to connect to the network and transmits data through the network interface. To protect factories, systems, machines, and networks from cyber attacks and ensure safe operation, a proper industrial information security protection mechanism must be implemented.

Customers are responsible for providing and maintaining a secure connection between the product and their network or any other network to protect their factories, systems, machines, and networks from unauthorized access. The system or machine can be connected to the enterprise network or the Internet only when secure connections are established and appropriate security measures are taken (such as using anti-virus software or installing firewalls).

Inovance continuously develops and improves products and solutions to improve safety. It is strongly recommended to keep your products updated and always use the latest version.



Tampering with software (such as viruses, Trojans, and Worms) can lead to unsafe device state, which can put the device in an unsafe operation state. This may result in death, serious injury, and property damage. Observe the following strictly.

- Always use the latest software version. If the product version is no longer supported or the latest version of the program is not applied, customers are at increased risk of cyber-attacks.
 - Take proper protection measures (including but not limited to deploying antivirus software, firewall, WAF, IPS/IDS, situational awareness system, ID verification, and data encryption) to prevent files in the mobile storage device from being damaged by malware and protect products, networks, systems, and interfaces from unauthorized access, disturbance, intrusion, data disclosure, or information theft.
 - Check all safety-related interfaces and settings after commissioning.
-

2 Product Information

2.1 Model and Nameplate

Naming rules

GS
20
-IOL
-8
AD
H

①
②
③
④
⑤
⑥

<p>① Product Family GS: High protection module</p> <p>② Serial No. 20: 20 series</p> <p>③ Protocol IOL: IO-Link</p>	<p>④ Number of Channels 8: 8 channels</p> <p>⑤ Input/Output Type AD: Analog input</p> <p>⑥ Material H: PPS polyphenylene sulfide</p>
--	---

Nameplate

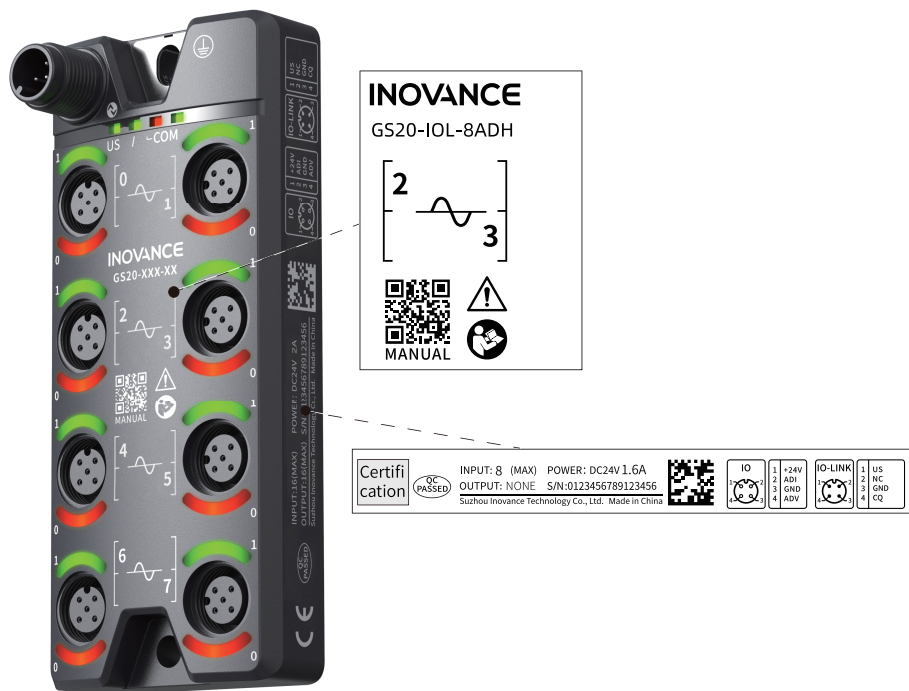

The data for ordering the product is shown in the following table.

Model	Description	Product Code	Applicable Model
GS20-IOL-8ADH-INT	GS20 series 8-channel analog (voltage/current) input configurable module	01441826	Class A IO-Link master

2.2 Components

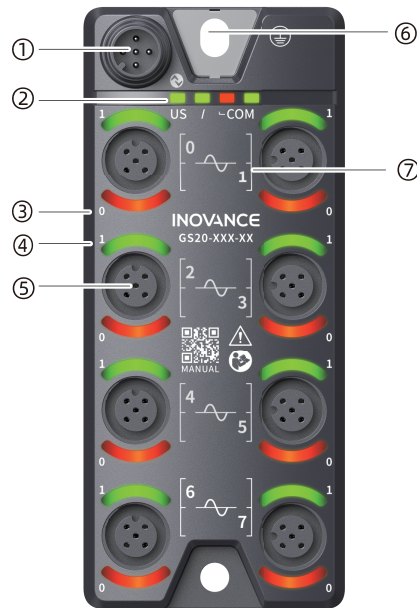

No.	Name	Description		
①	IO-Link port	It is used for IO-Link data transmission. For details, see “4.2 Terminal Assignment” on page 20		
②	Status indicator	US	System power supply indicator	<ul style="list-style-type: none"> • Steady green: Voltage is normal (18 VDC to 30.2 VDC). • Single flashing in green: Voltage is normal (11 VDC to 18 VDC). • Flashing in green: Voltage is normal (> 30.2 VDC). • OFF: Voltage is normal (< 11 VDC) and the module cannot operate normally.
		COM	IO-Link communication indicator	<ul style="list-style-type: none"> • Steady green: No communication • Slow flashing in green: IO-Link communication is normal. • Flashing in red: The module reports diagnostic information. • Off: The module has no voltage.
③	AD status indicator	0	Pin status indicators for port 0 to port 7	See the table below for indicator status description.
④		1		
⑤	I/O port	I/O port 2. For details on pin definitions, see “4.2 Terminal Assignment” on page 20		
⑥	PE port		During installation, ensure that the protective grounding terminal of the module is grounded properly, with a recommended grounding impedance of less than 1 Ω.	
⑦	Port number	0 to 7	There are eight analog input/output ports.	

Status of indicators 0 and 1 is shown in the table below:

	Indicator		Description
	0	1	
Off	Off	Off	No input
Off		Steady red	Pin 2 (current sampling) and Pin 4 (voltage sampling) exceed the detection range.

Indicator		Description
0	1	
Off	Solid green	Pin 2 (current sampling) and Pin 4 (voltage sampling) input is normal.
Steady red	Steady red	Pin 1 (24 V output) is short-circuited.

The indicator's quick flashing/single flashing/flashing is defined as shown in the table below.

Status	Definition
Single flashing	The indicator is on for 200 ms and off for 1000 ms, repeating this cycle.
Flashing	The indicator is on for 200 ms and off for 200 ms, repeating this cycle.
Flashing slowly	The indicator is on for 900 ms and off for 100 ms, repeating this cycle.

2.3 Technical Specifications

General specifications

Item	Specification
Dimensions (W × H × D)	54.2 mm × 148.2 mm × 35.2 mm
Weight	Approx. 111 g

Power supply specifications

Item	Specification
Rated voltage of US power supply	24 VDC (18 VDC to 30.2 VDC)
Maximum current of US power supply	1.6 A (max@24 V)
Sensor power supply	Supported
Isolation	No
US reverse polarity protection	Supported
Overvoltage/Undervoltage detection	Supported
Input undervoltage detection threshold	16 VDC to 18 VDC
Interface type	M12 A-coded male connector

AI input specifications

Item	Specification
Input type	Analog input
Configuration of inputs	Supported
Input type	Voltage and current
Number of input channels	8 channels
Conversion rate	30 ms/module
Input voltage range	0 V to 10 V, -10 V to +10 V
Voltage input accuracy (25°C)	±0.1% (full scale)
Voltage input accuracy (-30°C to +70°C)	±0.3% (full range)
Resolution	16-bit

Item	Specification
Current input range	4 mA to 20 mA, 0 mA to 20 mA
Current input accuracy (25°C)	±0.1% (full scale)
Voltage input accuracy (-30°C to +70°C)	±0.3% (full range)
Current input limit	21 mA
Voltage input diagnosis	Supports overflow and underflow diagnosis
Current input diagnosis	Supports disconnection diagnosis (only for 4 mA to 20 mA) Supports overlimit and overflow diagnosis
Input impedance	Current input: < 300 Ω; Voltage input: 1 MΩ
Isolation	No

IO-Link specifications

Item	Specification
IO-Link version	1.1.3
Transmission rate	COM3 (230.4 kbps)
Minimum cycle time	4 ms
Parameter backup	Supported
Unshielded cable length	Max. 20 m
IO-Link port type	Class A

Software specifications

Item	Specification
Input process data volume	24 bytes
Independent channel configuration	Supported
Diagnostic reporting function	Supported
Diagnostic detection configuration	Supports current-based disconnection detection (not supported by output range containing 0)
Output status in the stop mode	Output zero, last value, or preset value
Digital range conversion	<ul style="list-style-type: none"> • - 20000 to +20000 • - 32000 to +32000 • - 27648 to +27648 • -32768 to +32768 See the table below for details on digital values and limit ranges corresponding to analog inputs.
Output in the stop mode	Output according to fault stop mode and preset values without refreshing
Sampling refresh mode	Refreshes asynchronously according to the sampling time, and is not required to synchronize with the bus cycle

The following table shows the digital range and limit range corresponding to the analog voltage input range and analog current input range.

Rated Range	Rated Digital Value Range		Overlimit Condition	Limit	Digital Limit Range	Overflow/ Underflow Condition
-10 V to +10 V	16-bit resolution	-20000 to +20000	Rated digital value range used as overlimit condition	-10.5 V to +10.5 V	-21000 to +21000	The input exceeds the range by 5%.
		-32000 to +32000		-10.24 V to +10.24 V	-32767 to +32767	
		-27648 to +27648		-10.5 V to +10.5 V	-29030 to +29030	
		-32767 to +32767		-10 V to +10 V	-32767 to +32767	
	14-bit resolution	-7801 to +7801		-10.5 V to +10.5 V	-8191 to +8191	
	12-bit resolution	-1949 to +1949		-10.5 V to +10.5 V	-2047 to +2047	
	10-bit resolution	-486 to +486		-10.5 V to +10.5 V	-511 to +511	
0 V to 10 V	16-bit resolution	0 to 20000		-0.5 V to +10.5 V	-1000 to +21000	
		0 to 32000		-0.5 V to +10.24 V	-1600 to +32767	
		0 to 27648		-0.5 V to +10.5 V	-1382 to +29030	
		0 to 32767		-0.5 V to +10 V	-1638 to +32767	
	14-bit resolution	0 to 7801		-0.5 V to +10.5 V	-390 to +8191	
	12-bit resolution	0 to 1949		-0.5 V to +10.5 V	-97 to +2047	
	10-bit resolution	0 to 486		-0.5 V to +10.5 V	-24 to +511	
0 mA to 20 mA	16-bit resolution	0 to 20000	-1 mA to +21 mA	-1000 to +21000		
		0 to 32000	-1 mA to +20.48 mA	-1600 to +32767		
		0 to 27648	-1 mA to +21 mA	-1382 to +29030		
		0 to 32767	-1 mA to +20 mA	-1638 to +32767		
	14-bit resolution	0 to 7801	-1 mA to +21 mA	-390 to +8191		
	12-bit resolution	0 to 2047	-1 mA to +21 mA	-97 to +2047		
	10-bit resolution	0 to 511	-1 mA to +21 mA	-24 to +511		
4 mA to 20 mA	16-bit resolution	0 to 20000	-3.2 mA to +20.8 mA	-1000 to +21000		
		0 to 32000	-3.2 mA to +20.38 mA	-1600 to +32767		
		0 to 27648	-3.2 mA to +20.8 mA	-1382 to +29030		
		0 to 32767	-3.2 mA to +20 mA	-1638 to +32767		
	14-bit resolution	0 to 8191	-3.2 mA to +20.8 mA	-390 to +8191		
	12-bit resolution	0 to 2047	-3.2 mA to +20.8 mA	-97 to +2047		
	10-bit resolution	0 to 511	-3.2 mA to +20.8 mA	-24 to +511		

2.4 Environmental Specifications

Item	Operation Specification	Transmission Specification	Storage Specification
IP rating	IP67 (with screws tightened)		
Pollution degree	Level 2		
Immunity	2 kV on power supply line (IEC61000-4-4)		
Overvoltage category	I		
EMC immunity level	Zone B, IEC61131-2		
Anti-static rating	Contact discharge +/-6 kV and air discharge +/-8 kV		
Temperature	-30°C to +70°C	-40°C to +85°C	-40°C to +85°C
Humidity	10% RH to 99% RH, without condensation 100% (when all connectors are installed)		
Vibration	Frequency	5 Hz to 500 Hz	
	Displacement	1 mm (direct installation) (5 Hz to 61 Hz)	
	Acceleration	15 g (direct installation) (61 Hz to 500 Hz)	
	Direction	3-axial directions	
Shock resistance	Application/Transportation scenario: Tested according to IEC60068-2-27; 15 g peak acceleration, 11 ms pulse width, 18 shocks in total in X, Y and Z axes		
Altitude/Air pressure	0 m to 2000 m (> 79.5 kPa)		

3 Mechanical Installation

3.1 Installation Dimensions

The following figure describes the module installation dimensions (in mm).

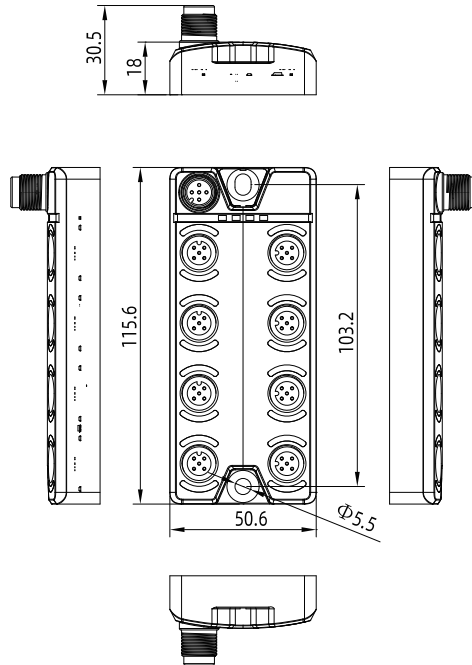

3.2 Installation Procedure

Installation

Install the module with two cross recessed hexagon SEMS screws (M5 x 25) with the washer diameter of 11 mm. The clearance between the two screws is 103.2 mm. The following figure describes the installation and clearance.

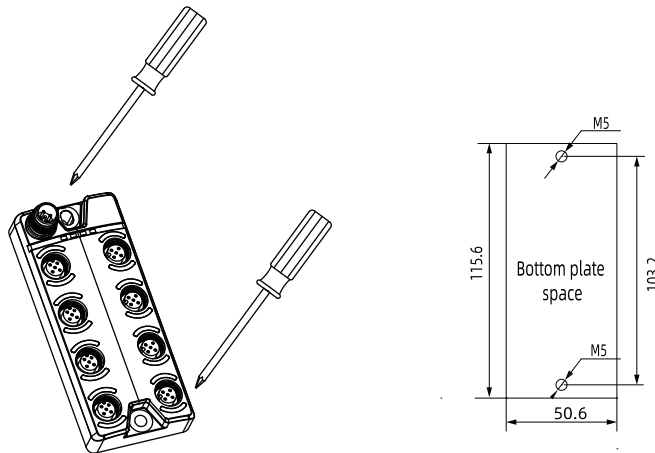

Removal

Remove the M5 screws using a Phillips screwdriver, and then detach the module.

4 Electrical Installation

4.1 Cable Selection

IO-Link communication cable

The data for ordering IO-Link communication cables are as follows.

Model	Description	Length	Material Code
CAB-M12AMS4-M12AFL4-3	Cable assembly - IO-Link cable - Male (straight) - 22AWG - Black - Female (angled) - 85°C (used for connecting the IO-Link master to IO-Link slaves)	3 m	15310142
CAB-M12AMS4-M12AFL4-5		5 m	15310184
CAB-M12AMS4-M12AFL4-8		8 m	15310230
CAB-M12AMS4-M12AFL4-10		10 m	15310183
CAB-M12AMS4-M12AFL4-15		15 m	15310182
CAB-M12AMS4-M12AFL4-3-T-taiyo	Cable assembly - IO-Link cable - Male (straight) - 22AWG - Black - Female (angled) - 85°C - Highly flexible cables fit for drag chains, surviving 3 to 5 million continuous tests (used for connecting the IO-Link master to IO-Link slaves)	3 m	15310232
CAB-M12AMS4-M12AFL4-5-T-taiyo		5 m	15310231
CAB-M12AMS4-M12AFL4-8-T-taiyo		8 m	15310229
CAB-M12AMS4-M12AFL4-10-T-taiyo		10 m	15310228
CAB-M12AMS4-M12AFL4-15-T-taiyo		15 m	15310227

Plug and connector assembly

The data for ordering connectors are as follows.

Model	Description	Material Code
CON-M12AFS4	4-core female straight connector, which can be connected directly	15051155
CON-M12AFL4	4-core female elbow connector, which can be connected directly	15051157
CON-M12AMS5	5-core male straight connector, which can be connected directly	15051156
CON-M12AML5	5-core male elbow connector, which can be connected directly	15051158
CON-M12AMS5-YF5	Y splitter that converts one 5-pin male M12 connector to two 5-pin female M12 DIO connectors	15051159
CON-M12AMS4-YM8F3	Y splitter that converts one M12 5-pin A-code male straight connector to two M8 3-pin female connectors	15051420
CON-M12AMS4-YM8F4	Y splitter used for converting one M12 5-pin A-code male straight connector to two M8 4-pin female connectors	15051419
CON-M8AMS3	M8 3-pin assembled connector	15051445
CON-M8AMS4	M8 4-pin assembled connector	15051448
CON-M12AFS5-YM5	Y splitter that converts one 5-pin female connector to two 5-pin male straight connectors. It can be used to connect the class A master to class B valve terminal slave.	15051334

Model	Description	Material Code
IPT210-A-CAB-M12AMS5-M12AF55-1.5	Connector that converts 5-pin male straight connector to 5-pin female straight connector. It can be used to connect the IO-Link master to valve terminal.	72235829
IPT210-A-CAB-M12AF55-1.5	Connector that converts 5-pin female straight connector to discrete cable. It can be used to power the valve terminal.	72235870

Note

If you have additional requirements for IO-Link cables, contact Inovance for customization.

4.2 Terminal Assignment

IO-Link port pins

The IO-Link port is an M12A male port. The following figure describes pin numbers and the following table describes pins in details.

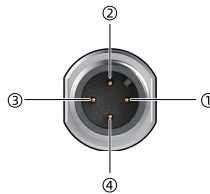

No.	Description
①	System and sensor power supply US (+)
②	Not connected
③	System and sensor power supply US (-)
④	C/Q, IO-Link data transmission

Port pins

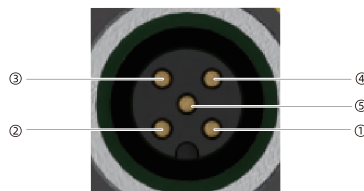

No.	Description
①	Port 0 to Port 7: Port analog 24 V power output for sensors
②	Port 0 to Port 7: Analog current input
③	System ground
④	Port 0 to Port 7: Analog voltage input
⑤	Not connected

4.3 Terminal Wiring

Precautions

- Do not bundle the expansion cable together with power cables (high voltage, large current) which produce strong interference signals; otherwise, it may be influenced by noise, surge and induction. Separate it from other cables (for > 30 cm) and avoid cabling in parallel.
- When it is unavoidable to route cables close to power cables (with high voltage, high current) or other cables transmitting strong interference signals, shielded cables must be used for extended cables to enhance interference resistance. Different analog signals shall use separate shielded cables.
- Apply single-point grounding for the shield of shielded cables and soldered cables.



Caution

This product adopts M12 A-coded connectors for IO-Link and I/O ports. The recommended tightening torque for the connector cable is 0.5 N·m, with a maximum of 0.8 N·m. Exceeding 1.0 N·m may pose a risk of damaging the circuit board.

Terminal wiring diagram

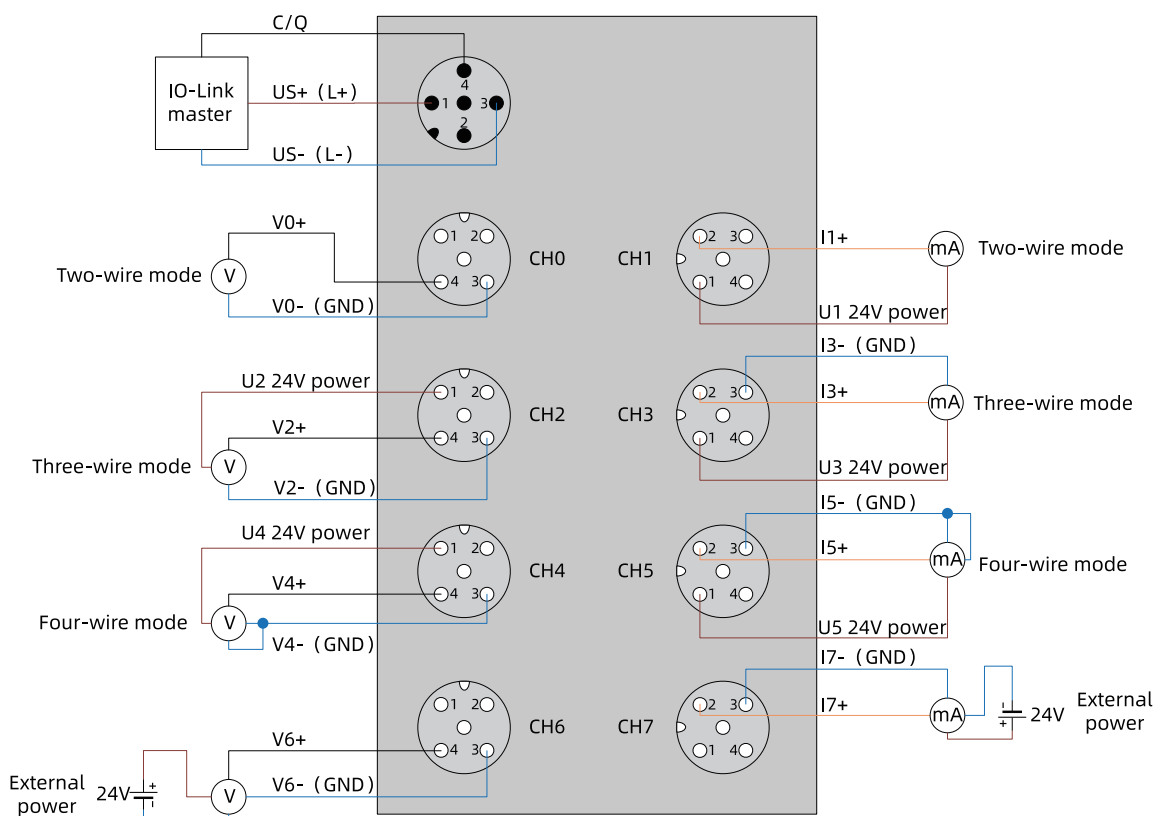

6 Object List

6.1 Protocol Stack Data

Baud rate	COM3 (230.4 kbps)
Minimum cycle time for process data	4 ms
IO-Link version	1.1.3
Vendor ID	0x0659
Device ID	-

6.2 Process Data

Byte	0							
Bit	0	1	2	3	4	5	6	7
Pin	Portn							
Default	0	0	0	0	0	0	0	0
Function	Switch 1	Switch 2	Overflow	Overlimit	Reserved		Discon- nected	Short- circuited
Byte	1							
Bit	0	1	2	3	4	5	6	7
Pin	Portn							
Default	0	0	0	0	0	0	0	0
Function	Portn analog input process data (displayed according to the configured process data range and alignment mode)							
Byte	2							
Bit	0	1	2	3	4	5	6	7
Pin	Portn							
Default	0	0	0	0	0	0	0	0
Function	Portn analog input process data (displayed according to the configured process data range and alignment mode)							

6.3 Product Data

Index	Subindex	Object	Length	Data Storage	Default
0x07	-	VendorID	2 bytes	-	0x0659
0x08	-	DeviceID	2 bytes	-	0xF42A20
0x10	-	VendorName	8 bytes	-	INOVANCE
0x11	-	VendorText	16 bytes	-	Website: https://www.inovance.com/global
0x12	-	ProductName	21 bytes	-	GS20-IOL-8ADH
0x13	-	ProductID	7 bytes	-	1440950
0x14	-	ProductText	23 bytes	-	GS20-8ADH: 8-channelVoltageandCurrentAnalogInPutClassAIO-linkdevice
0x16	-	HardwareRevision	4 bytes	-	U1A00
0x17	-	FirmwareRevision	4 bytes	-	V1R1C1L00B0T0
0x44	2	System status monitoring	2 bytes	No	0x0000

Index	Subindex	Object	Length	Data Storage	Default
0x48	1	MCU temperature setting	1 byte	Yes	0x0050
0x51	8	Pin1 short circuit	1 byte	No	0x0000
0x140	8	Data alignment	8 bytes	Yes	0x0000
0x141	8	Port mode setting	8 bytes	Yes	0x0001
0x142	8	Switch point 1	16 bytes	Yes	0x0000
0x143	8	Switch point 2	16 bytes	Yes	0x0000
0x144	16	Switch point enable	16 bytes	Yes	0x0000
0x145	8	Filter settings	8 bytes	Yes	0x0001
0x146	8	Resolution	8 bytes	Yes	0x0000
0x147	8	ADC value	8 bytes	No	0x0000
0x148	8	Over-limit enable	2 bytes	Yes	0x0000
0x149	8	Process data format	8 bytes	Yes	0x0000
0x14A	8	Wire break enable	1 byte	Yes	0x0000
0x14F	-	Sample period setting	1 byte	Yes	0x0004

Note

The following are explanations for some parameters in the table:

- R/W: Read/Write, indicating the index is readable and writable.
- R: Read-only, indicating the index is read-only.
- DS: Parameter data storage. Yes indicates the data will be stored in the device and retained after power loss; NO indicates it will not be stored.

Module operation status monitoring																	
	Byte	0							1								
	Bit	0	1	2	3	4	5	6	7	0	1	2	3	4	5	6	7
	Pin	T	-	-	-	-	-	-	-	US	-	-	-	-	-	-	-
	Subindex	1	-	-	-	-	-	-	-	2	-	-	-	-	-	-	-
	Default	0	-	-	-	-	-	-	-	0	-	-	-	-	-	-	-
0x44 R	Data storage	No															
	Function	00: 18 V < US < 30.2 V 01: 11 V < US < 18 V 10: US > 30.2 V 11: US < 11 V T = 0: MCU operating within set temperature range T = 1: MCU operating outside set temperature range															

MCU operating environment temperature monitoring upper limit									
0x48 R/W	Byte	0							
	Bit	0	1	2	3	4	5	6	7
	Pin	-							
	Subindex	1							
	Default	0x50							
	Data storage	Yes							
	Function	Set MCU operating temperature detection limit (not storage temperature): upper limit 120°C Others: Reports a fault and operates according to the previous configuration value.							

Port function pin short circuit status readback									
0x51 R	Byte	0							
	Bit	0	1	2	3	4	5	6	7
	Pin	Pin 1 of Port 0	Pin 1 of Port 1	Pin 1 of Port 2	Pin 1 of Port 3	Pin 1 of Port 4	Pin 1 of Port 5	Pin 1 of Port 6	Pin 1 of Port 7
	Subindex	1	2	3	4	5	6	7	8
	Default	0	0	0	0	0	0	0	0
	Data storage	No							
	Function	0: Normal operation 1: Pin short circuit							

Note

If the hardware does not support short-circuit detection, this index does not exist.

Analog port function configuration parameters									
0x140 R/W	Byte	0							
	Bit	0	1	2	3	4	5	6	7
	Pin	Port 0	Port 1	Port 2	Port 3	Port 4	Port 5	Port 6	Port 7
	Subindex	1	2	3	4	5	6	7	8
	Default	0	0	0	0	0	0	0	0
	Data storage	Yes							
	Function	0: Right alignment 1: Left alignment							

Analog port function selection									
0x141 R/W	Byte	0	1	2	3	4	5	6	7
	Bit	-	-	-	-	-	-	-	-
	Pin	Port 0	Port 1	Port 2	Port 3	Port 4	Port 5	Port 6	Port 7
	Subindex	1	2	3	4	5	6	7	8
	Default	1	1	1	1	1	1	1	1
	Data storage	Yes							
Function	0: Disabled 1: 0 V to 10 V (voltage) 2: -10 V to +10 V (voltage) 8: 0 mA to 20 mA (current) 9: 4 mA to 20 mA (current with disconnection detection enabled) Others: Reports a fault and operates according to the previous configuration value.								

Analog input switching point 1 preset value																	
0x142 R/W	Byte	0	1	2	3	4	5	6	7	8	9	10	11	12	13	14	15
	Bit	-	-	-	-	-	-	-	-	-	-	-	-	-	-	-	-
	Pin	Port 1	Port 2	Port 3	Port 4	Port 5	Port 6	Port 7	Port 8								
	Subindex	1	2	3	4	5	6	7	8								
	Default	0	0	0	0	0	0	0	0	0	0	0	0	0	0	0	0
	Data storage	Yes															
Function	Set the display range according to the configured process data																

Analog input switching point 2 preset value																	
0x143 R/W	Byte	0	1	2	3	4	5	6	7	8	9	10	11	12	13	14	15
	Bit	-	-	-	-	-	-	-	-	-	-	-	-	-	-	-	-
	Pin	Port 1	Port 2	Port 3	Port 4	Port 5	Port 6	Port 7	Port 8								
	Subindex	1	2	3	4	5	6	7	8								
	Default	0	0	0	0	0	0	0	0	0	0	0	0	0	0	0	0
	Data storage	Yes															
Function	Set the display range according to the configured process data																

Switching point enabling setting									
0x144 R/W	Byte	0							
	Bit	0	1	2	3	4	5	6	7
	Pin	Port 0 switching point 1	Port 1 switching point 1	Port 2 switching point 1	Port 3 switching point 1	Port 4 switching point 1	Port 5 switching point 1	Port 6 switching point 1	Port 7 switching point 1
	Subindex	1	2	3	4	5	6	7	8
	Default	0	0	0	0	0	0	0	0
	Byte	1							
	Bit	1	1	1	1	1	1	1	1
	Pin	Port 0 switching point 2	Port 1 switching point 2	Port 2 switching point 2	Port 3 switching point 2	Port 4 switching point 2	Port 5 switching point 2	Port 6 switching point 2	Port 7 switching point 2
	Subindex	9	10	11	12	13	14	15	16
	Default	0	0	0	0	0	0	0	0
	Data storage	Yes							
	Function	0: Disable 1: Enable							

Analog port input filtering									
0x145 R/W	Byte	0	1	2	3	4	5	6	7
	Bit	-	-	-	-	-	-	-	-
	Pin	Port 0	Port 1	Port 2	Port 3	Port 4	Port 5	Port 6	Port 7
	Subindex	1	2	3	4	5	6	7	8
	Default	1	1	1	1	1	1	1	1
	Data storage	Yes							
	Function	1 to 25 (Filter value = Set value × Sampling cycle). Under default settings, the accuracy at 25°C is ±0.1% (full scale).							

Analog port input resolution setting									
0x146 R/W	Byte	0	1	2	3	4	5	6	7
	Bit	-	-	-	-	-	-	-	-
	Pin	Port 0	Port 1	Port 2	Port 3	Port 4	Port 5	Port 6	Port 7
	Subindex	1	2	3	4	5	6	7	8
	Default	0	0	0	0	0	0	0	0
	Data storage	Yes							
	Function	0: 16 bits 1: 14 bits 2: 12 bits 3: 10 bits							

Raw analog input value readback									
0x147 R	Byte	0 to 2	3 to 5	6 to 8	9 to 11	12 to 14	15 to 17	18 to 20	21 to 23
	Bit	-	-	-	-	-	-	-	-
	Pin	Port 1	Port 2	Port 3	Port 4	Port 5	Port 6	Port 7	Port 8
	Subindex	1	2	3	4	5	6	7	8
	Default	0	0	0	0	0	0	0	0
	Data storage	No							
Function	Set the display range according to the configured process data								

Overflow and overlimit detection setting										
0x148 R/W	Byte	0								
	Bit	0	1	2	3	4	5	6	7	
	Pin	Port 0 over-flow	Port 0 overlimit	Port 1 overflow	Port 1 overlimit	Port 2 over-flow	Port 2 overlimit	Port 3 over-flow	Port 3 overlimit	
	Subindex	1		2		3		4		
	Default	0	0	0	0	0	0	0	0	
	Byte	1								
	Bit	8	9	10	11	12	13	14	15	
	Pin	Port 4 over-flow	Port 4 overlimit	Port 5 overflow	Port 5 overlimit	Port 6 over-flow	Port 6 overlimit	Port 7 over-flow	Port 7 overlimit	
	Subindex	5		6		7		8		
	Default	0	0	0	0	0	0	0	0	
	Data storage	Yes								
	Function	0: Disable 1: Enable								

Process data display range setting										
0x149 R/W	Byte	0	1	2	3	4	5	6	7	
	Bit	-	-	-	-	-	-	-	-	
	Pin	Port 0	Port 1	Port 2	Port 3	Port 4	Port 5	Port 6	Port 7	
	Subindex	1	2	3	4	5	6	7	8	
	Default	0	0	0	0	0	0	0	0	
	Data storage	Yes								
	Function	0: -20000 to +20000 1: -32000 to +32000 2: -27648 to +27648 3: -32768 to +32768 64: Unsigned 128: Scaled to mV/ μ A Others: Reports a fault and operates according to the previous configuration value.								

Disconnection detection function switch									
0x14A R/W	Byte	0							
	Bit	0	1	2	3	4	5	6	7
	Pin	Port 0	Port 1	Port 2	Port 3	Port 4	Port 5	Port 6	Port 7
	Subindex	1	2	3	4	5	6	7	8
	Default	0	0	0	0	0	0	0	0
	Data storage	Yes							
	Function	0: Disable 1: Enable							

Sampling cycle									
0x14F R/W	Byte	0							
	Bit	0	1	2	3	4	5	6	7
	Pin	-	-	-	-	-	-	-	-
	Default	4							
	Data storage	Yes							
	Function	1 ms to 50 ms Others: Reports a fault and operates according to the previous correct value. Under default settings, this fault handling behavior meets the product specifications.							

7 Fault Diagnosis

The fault codes of the slave are reported to the master, where you can view the fault information, as shown below.

Fault Code	Fault Type	Description	Solution
0x4210	Warning	Overtemperature	The ambient temperature is high. Lower down the temperature before using the module.
0x4220	Warning	Low temperature	The ambient environment is low. Increase the temperature before using the module.
0x5011	Error	Loss of data for which retention upon power-off is configured	Configuration of retention upon power-off fails. Re-configure the parameter for retention upon power-off.
0x5110	Warning	System power supply overvoltage	The US power supply voltage of the module is higher than the normal operating voltage. Reduce the US power supply voltage. Note: This fault is reported in the fault log and only occurs in medium-sized PLCs.
0x5111	Warning	System power supply undervoltage	The US power supply voltage of the module is lower than the normal operating voltage. Increase the US power supply voltage.
0x6320	Error	Parameter error	The module parameters have been configured incorrectly. Configure the parameters correctly according to the product data.
0x7710	Error	Module short circuit	The module encounters short circuit. Check the external wiring.
0x8C20	Error	Measured value exceeds the limit	Check the application environment.
0x770n (n: 1 to 8)	Error	Open circuit for port 0 to 7	Check whether the input connection is normal.
0x8C1n (n: 1 to 8)	Warning	Input data exceeds the upper limit for port 0 to 7	Check whether the input is correct
0x8C2n (n: 1 to 8)	Error	Input data overflow for port 0 to 7	Check whether the input is correct
0x8C3n (n: 1 to 8)	Warning	Input data exceeds the lower limit for port 0 to 7	Check whether the input is correct

8 Appendix: Version Matching Information

You can get the firmware of the module from Inovance technical support engineers and the InoProShop software from the software and commissioning tool interface of medium-sized PLCs at <https://www.inovance.com>. The following table describes the version matching information.

Module Firmware Version	InoProShop Version
V1R1C1L00B0T0 and later	V1.7.3 SP2 and later

Service and Support

Should you encounter a safety accident during the use or operation of the product, or face challenges in operating and maintaining the equipment, which remain unresolved after the relevant documentation is consulted, we provide multiple channels to ensure prompt resolution:

- Channel #1: Contact service@inovance.com.
- Channel #2: Visit <https://www.inovance.com/global> to access document downloads, after-sales support, spare parts ordering, repair applications, and authenticity verification services.
- Channel #3: Download My Inovance app (<https://zshc-eu.inovance.com/download-pc/>) where you can access products info and documentation, and query product parameters.

We are committed to providing you with quick and professional technical support, and we look forward to your satisfaction and trust.



Copyright © Shenzhen Inovance Technology Co., Ltd.

PS00021555A01

Shenzhen Inovance Technology Co., Ltd.

www.inovance.com

Suzhou Inovance Technology Co., Ltd.

www.inovance.com

Add.: Inovance Headquarters Tower, High-tech Industrial Park,
Guanlan Street, Longhua New District,
Shenzhen 518000, P.R. China

Tel: (0755) 2979 9595

Fax: (0755) 2961 9897

Add.: No. 52, Tian E Dang Road, Wuzhong District, 215104,
Suzhou City, Jiangsu Province, P.R. China

Tel: (0512) 6637 6666

Fax: (0512) 6285 6720