

AM76X-INT Programmable Logic Controller User Guide



Industrial
Automation



New Energy
Vehicle



Intelligent
Elevator



Intelligent
Robot



Digital
Energy



Rail
Transit



Legal Information

■ Copyright

Copyright © 2024 Shenzhen Inovance Technology Co., Ltd. All rights reserved.

This documentation is the exclusive property of Shenzhen Inovance Technology Co., Ltd. No individual or entity may excerpt, reproduce, modify, translate, or distribute any content herein without written consent from Inovance.

Legal action will be taken against infringement.

■ Trademarks

INOVANCE is a registered trademark of Shenzhen Inovance Technology Co., Ltd. and its affiliates. All other trademarks or registered trademarks mentioned in this documentation are the property of their respective owners. Unauthorized use of these trademarks by third parties for any purpose without written authorization could violate the rights of their owners.

■ Disclaimer of Liability

Due to continuous updates and improvements of products and technologies, the content of this documentation may not fully match the actual products. In the event of any discrepancies, the actual products shall prevail.

The contents are subject to change without notice due to product upgrade.

■ Waste Disposal

The storage, use, and disposal of this product (including optional accessories) must comply with local laws and regulations.

■ Qualified Personnel

The product/system described in this documentation may be operated only by personnel qualified for the specific task in accordance with the relevant documentation, in particular its warning notices and safety instructions. Qualified personnel can identify the risks of the product/system and prevent possible dangers.

■ Proper Use of the Product

Proper transportation, storage, assembly, installation, commissioning, operation, and maintenance are required to ensure the safe operation of the product without any problems. The required ambient conditions must be met. All operations must follow the guidelines provided in this documentation.

Preface

■ Introduction

This medium-sized programmable logic controller (PLC) features high performance, flexible expansion, and excellent stability. Designed for multi-axis synchronous control and multi-channel Ethernet communication, it is widely applied in industries such as silicon wafers, automobiles, lithium batteries, packaging, and metal cables.

This guide describes product information, installation, cable connection, power-on and power-off procedures, as well as maintenance instructions.

■ Compliance

The following table lists the certifications, directives, and standards that the product may comply with. For details about the acquired certificates, see the certification marks on the product nameplate.

Certification	Directive		Standard
CE	EMC	2014/30/EU	24 VDC products: EN 61131-2 220 VAC products: EN 61131-2 EN 61000-3-2 EN 61000-3-3
	LVD	2014/35/EU	EN 61010-1 EN 61010-2-201
	RoHS	2011/65/EU amended by (EU) 2015/863	EN IEC 63000
UL/cUL	-		UL 61010-1 UL 61010-2-201 CAN/CSA-C22.2 No. 61010-1 CSA C22.2 NO. 61010-2-201
KCC	-		-
EAC	-		-

Certification	Directive		Standard
UKCA	Safety Regulations	Electrical Equipment (Safety) Regulations 2016	EN 61010-1 EN 61010-2-201
	EMC	Electromagnetic Compatibility Regulations 2016	24 VDC products: EN 61131-2 220 VAC products: EN 61131-2 EN 61000-3-2 EN 61000-3-3
	RoHS	Directive (RoHS) Regulations 2012	EN IEC 63000

■ More Data

Data Name	Data Code	Description
Medium-Sized PLC Programming Software User Guide	19010980	Describes the basic functions, quick start, network settings, and programming basics of the medium-sized PLC programming software
Medium-Sized PLC Programming Guide (Motion Control)	19012378	Describes the composition of the PLC motion control system, mechanism of the motion control program, motion control (MC) instructions, and simulation and commissioning related operations
Medium-Sized PLC Instruction Guide	19012377	Describes basic instructions of the medium-sized PLC
AM76X-INT Programmable Logic Controller User Guide (this guide)	PS00017374	Describes product information, installation, cable connection, power-on and power-off procedures, as well as maintenance instructions.

■ Revision History

Date	Version	Description
January 2026	A02	Updated the product image and product code.
February 2025	A01	Minor corrections.
May 2024	A00	Initial release.

■ Access to the Guide

This guide is not in the scope of delivery. If necessary, you can download the PDF file in the following ways:

- Visit <https://www.inovance.com/global>, choose Service&Support > Support.
- Scan the QR code on the product with your smart phone.
- Scan the QR code below to install My Inovance app, where you can search for and download user guides.



■ Warranty Disclaimer

If your product becomes defective under normal use conditions, we will offer guaranteed repair services within the warranty period. Maintenance will be charged after the warranty period expires.

Even in the warranty period, a maintenance fee will be charged for repair of the following damage:

- Damage caused by operations not following the instructions in the guide
- Damage caused by fire, flood, or abnormal voltage
- Damage caused by unintended use of the product
- Damage caused by use beyond the specified scope of application of the product

- Damage or secondary damage caused by force majeure (such as natural disaster, earthquake, and lightning strike)

The maintenance fee will be charged according to our latest Price List if not otherwise agreed upon.

For details, see the Product Warranty Card.

1 Fundamental Safety Instructions

1.1 Safety Precautions

■ Safety Disclaimer

- This chapter presents essential safety precautions for proper use of the product. Before use, read through the user guide and comprehend all the safety precautions. Failure to observe the safety instructions may result in equipment damage, physical injuries, or even death.
- "DANGER", "WARNING", and "CAUTION" items in this guide do not indicate all safety precautions that need to be followed; instead, they just supplement the safety precautions.
- Use this product in an environment that complies with the design specifications. Malfunction or component damage caused by improper use is not covered by warranty.
- Inovance is not legally responsible for any personal safety accidents or property losses caused by improper operations of this equipment or violation to instructions in this guide.

■ Safety Levels and Definitions

 **DANGER** indicates that failure to comply with the notice will result in severe physical injuries or even death.

 **WARNING** indicates that failure to comply with the notice may result in severe physical injuries or even death.

 **CAUTION** indicates that failure to comply with the notice may result in minor or moderate physical injuries or equipment damage.

■ Safety Precautions

- Some drawings in this guide show the equipment without covers or protective guards to display more details. Remember to install the covers and protective guards before using the equipment and operate it in accordance with the instructions.

- Drawings in the user guide are for illustration only and may be different from the equipment you purchased.

Unpacking



- Do not install the product when you find that the product and its accessories have any damage or corrosion or they have been used.
- Do not install the product when there is water inside the product or any of its parts is missing or damaged.
- Do not install the product when the product name is inconsistent with that in the packing list.



- Before unpacking, check the package for any damage, water seepage, dampness, or deformation.
- Unpack the product layer by layer. Do not strike the package violently.
- Check the surfaces of the equipment and accessories for any damage, rust, and scratches.
- Check the equipment, accessories, and materials in the package against the packing list.

Storage and Transportation



- Store and transport the equipment based on the storage and transportation requirements. Failure to comply will result in equipment damage.
- Store and transport the product in environments free from water splashes, rain exposure, direct sunlight, strong electric and magnetic fields, and excessive vibration.
- Avoid storing the product for more than 3 months. When the product needs to be stored for an extended period, take more strict protection and necessary inspection.
- Package the product strictly before transporting it, and use an enclosed container for long-distance transportation.
- Never transport the product with other equipment or materials that may harm or have negative impacts on the product.

Installation



DANGER

- Installation must be carried out by technicians who have received relevant training on electrical equipment and have sufficient electrical expertise. Non-professionals are not allowed to operate the equipment.



WARNING

- Read through the user guide and safety precautions before installation.
- Do not install the product in places with strong electric or magnetic fields.
- Before installation, check that the mechanical strength of the installation site can bear the weight of the equipment. Failure to comply will result in mechanical hazards.
- Do not wear loose clothes or accessories during installation. Failure to comply may result in an electric shock.
- When installing the equipment in a closed environment (such as a cabinet or casing), use a cooling device (such as a fan or air conditioner) to cool the environment down to the required temperature. Failure to comply may result in equipment over-temperature or fire accidents.
- Do not modify the product.
- Do not fiddle with the bolts used to fix parts and components or the bolts marked in red.
- When installing the product in a cabinet or final assembly, make sure that the enclosure of the cabinet or final assembly provides adequate fire prevention, electrical protection, and mechanical protection conforming to relevant IEC standards and local laws and regulations.
- Before installing devices with strong electromagnetic interference, such as a transformer, install a shielding device for the equipment to prevent malfunction.
- Install the product on an incombustible object, such as metal, and do not touch or attach the product to combustibles. Failure to comply may result in fire accidents.



CAUTION

- Cover the top of the equipment with a piece of cloth or paper during installation. This is to prevent unwanted objects such as metal chippings, oil, and water from falling into the equipment and causing faults. After installation, remove the cloth or paper on top of the equipment to prevent over-temperature caused by poor ventilation due to blocked ventilation holes.
- Resonance may occur when the equipment operating at a constant speed executes variable speed operations. In this case, install the vibration-proof rubber under the motor frame or use the vibration suppression function to reduce resonance.

Wiring



DANGER

- Equipment installation, wiring, maintenance, inspection, or parts replacement must be performed by only professionals.
- Before wiring, cut off all the power supplies of the equipment. Wait for at least the time designated on the equipment warning label before further operations because residual voltage still exists after power-off. Measure the DC voltage of the main circuit and make sure that it is below the safety voltage. Failure to comply will result in an electric shock.
- Do not perform wiring, remove the equipment cover, or touch the circuit board with power on. Failure to comply will result in an electric shock.
- Make sure that the device is reliably grounded. Failure to comply will result in an electric shock.



WARNING

- Do not connect the input power supply to the output end of the equipment. Failure to comply can result in equipment damage or even fire.
- When connecting a drive to a motor, check that the phase sequences of the drive and motor terminals are consistent to prevent reverse motor rotation.
- Cables used for wiring must meet cross sectional area and shielding requirements. The shield of the cable must be reliably grounded at one end.
- Fix the terminal screws with the tightening torque specified in the user guide. Improper tightening torque may overheat or damage the connecting part, resulting in fire accidents.
- After wiring is done, check that all cables are connected properly and no screws, washers or exposed cables are left inside the equipment. Failure to comply may result in an electric shock or equipment damage.



CAUTION

- During wiring, follow the proper electrostatic discharge (ESD) procedures and wear an anti-static wrist strap. Failure to comply may result in damage to internal circuits of the equipment.
- Use shielded twisted pairs for the control circuit. Connect the shield to the grounding terminal of the equipment for grounding purpose. Failure to comply will result in equipment malfunction.

Power-on



DANGER

- Before power-on, check that the equipment is installed properly with reliable wiring and the motor can be restarted.
- Check that the power supply meets equipment requirements before power-on to prevent equipment damage or a fire.
- Do not open the cabinet door or protective cover of the product, touch any wiring terminal of the product, or remove any part of the product with power on. Failure to comply can result in an electric shock.

**WARNING**

- Perform a trial run after wiring and parameter setting to ensure the equipment operates safely. Failure to comply may result in physical injuries or equipment damage.
- Before power-on, check that the rated voltage of the equipment is consistent with that of the power supply. Failure to comply may result in fire accidents.
- Before power-on, check that no one is near the equipment, motor, or machine. Failure to comply may result in physical injuries or even death.

Operation**DANGER**

- The equipment must be operated only by professionals. Failure to comply will result in physical injuries or even death.
- Do not touch any connecting terminals or disassemble any unit or component of the equipment during operation. Failure to comply can result in an electric shock.

**WARNING**

- Do not touch the equipment casing, fan, or resistor with bare hands to feel the temperature. Failure to comply may result in personal injuries.
- Prevent metal or other objects from falling into the equipment during operation. Failure to comply may result in fire accidents or equipment damage.

Maintenance

**DANGER**

- Equipment installation, wiring, maintenance, inspection, or parts replacement must be performed by only professionals.
- Do not maintain the equipment with power on. Failure to comply will result in an electric shock.
- Before maintenance, cut off all the power supplies of the equipment and wait for at least the time designated on the equipment warning label.
- When a permanent magnet motor is used, do not touch the motor terminals immediately after power-off because the motor terminals can generate induced voltage during rotation even after the equipment power supply is off. Failure to comply can result in an electric shock.

**WARNING**

- Carry out daily and periodic inspection and maintenance on the equipment according to maintenance requirements and retain a maintenance record.

Repair**DANGER**

- Equipment installation, wiring, maintenance, inspection, or parts replacement must be performed by only professionals.
- Do not repair the equipment with power on. Failure to comply can result in an electric shock.
- Before inspection and repair, cut off all the power supplies of the equipment and wait for at least the time designated on the equipment warning label.



- Submit the repair request according to the warranty agreement.
- When the fuse is blown or the circuit breaker or earth leakage current breaker (ELCB) trips, wait for at least the time designated on the equipment warning label before power-on or further operations. Failure to comply may result in death, personal injury or equipment damage.
- When the equipment is faulty or damaged, require professionals to perform troubleshooting and repair by following repair instructions and keep a repair record.
- Replace quick-wear parts of the equipment in according with the replacement instructions.
- Do not perform operations on damaged equipment. Failure to comply may result in death, physical injuries, or severe equipment damage.
- After the equipment is replaced, check the wiring and set parameters again.

Disposal



- Dispose of retired equipment in accordance with local regulations and standards. Failure to comply may result in property damage, physical injuries, or even death.
- Recycle retired equipment by observing industry waste disposal standards to avoid environmental pollution.

■ Safety Labels

For safe equipment operation and maintenance, comply with the safety labels on the equipment. Do not damage or remove the safety labels. The following table describes the safety labels.

Safety Label	Description
	<ul style="list-style-type: none">• Read through the safety instructions and user guide before operating the equipment. Failure to comply may result in equipment damage, physical injuries, or even death.• Do not touch the terminals or remove the cover with power on or within 10 min after power-off. Failure to comply will result in an electric shock.

1.2 Industrial Information Security

This product provides an interface to connect to the network and transmit data through the network interface. To protect factories, systems, machines, and networks from cyber attacks, appropriate industrial information security protection mechanisms need to be implemented to ensure the safe operation of factories, systems, machines, and networks.

The customer is responsible for providing and continuously ensuring a secure connection between the product and the customer's network or any other network, to prevent unauthorized access to their factory, systems, machines, and networks. The system or machine may only be connected to the corporate network or the Internet when a secure connection is established and proper security measures are in place (for example, using antivirus software and installing firewalls).

INOVANCE continuously develops and improves its products and solutions to enhance safety. It is strongly recommended that you update your products promptly and always use the latest product versions.



Malware (such as viruses, Trojans, and worms) can bring the device into an unsafe operating state, resulting in death, serious injury, and property damage. Observe the following precautions strictly:

- Always use the latest software version. If the product version is no longer supported or the latest program version is not applied, customers are at increased risk of cyberattacks.
 - Implement and maintain appropriate security measures (including but not limited to deploying anti-virus software, firewall, WAF, IPS/IDS, situational awareness system, ID verification, and data encryption) to prevent files in the removable storage device from being damaged by malware and to protect products, networks, systems, and interfaces from unauthorized access, disruption, intrusion, data leakage, or information theft.
 - Check all safety-related interfaces and settings after commissioning.
-

2 Product Information

2.1 Model and Nameplate

■ Model

A M 7 6X-INT
① ② ③ ④ ⑤

① Product family A: Controller	③ Product series 7: 7 series
② Structure type M: Expandable PLC	④ Hardware configuration code 6X: X86 architecture, Celeron® CPU; X represents 3/4/5, indicating 32/ 64/96 axes respectively.
⑤ Version INT: International version	

■ Nameplate

AM765-INT
Programmable Logic Controller

POWER INPUT: DC24 V 4A
OUTPUT: NONE

SN: 0123456789123456



 Certification mark

A	B
CANH 1 5	485+
CANL 2 6	485-
CGND 3 7	CGND
⏻ 4 8	⏻

INOVANCE
www.inovance.com
Suzhou Inovance Technology Co.,Ltd.
Made in China

24 V



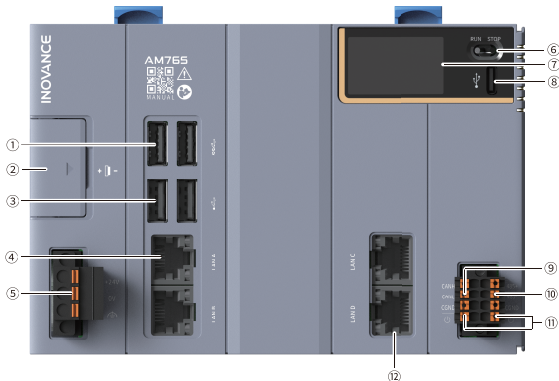

Model	Description
AM763-INT	Programmable controller AM763-INT — AM760-INT series general 32-axis PLC
AM764-INT	Programmable controller AM764-INT – AM760-INT series general 64-axis PLC
AM765-INT	Programmable controller AM765-INT – AM760-INT series general 96-axis PLC

2.2 Components



No.	Component	Mark	Description
①	USB 3.0		Two, type A
②	Battery compartment		Open the battery compartment to replace the button battery. For replacement procedure, see "7.3 Battery Maintenance" on page 49
③	USB 2.0		Two, type A
④	Ethernet interface	LAN A/LAN B	Two (Modbus TCP, EtherNet/IP, OPC UA, FINS TCP/UDP, MELSEC communication interfaces), 10/100/1000 Mbit/s auto-negotiation. For LED status and description, see "2.4 LED Indicator" on page 18

No.	Component	Mark	Description
⑤	24 V input power	+24V	Positive terminal of 24 VDC input power
		0V	Negative terminal of 24 VDC input power
			Functional ground of the PLC
⑥	DIP switch	RUN/STOP	Controls start/stop of the PLC.
⑦	LED display	-	Displays the PLC status. For details, see "2.3 LED Display" on page 17
⑧	Type-C interface		For internal commissioning, not for external use
⑨	CAN interface	CANH	CAN_H signal of CAN communication
		CANL	CAN_L signal of CAN communication
		CGND	Reference ground of CAN communication (The two CGND terminals are internally connected.)
⑩	RS485 interface	485+	Positive signal of RS485 communication
		485-	Negative signal of RS485 communication
		CGND	Reference ground of RS485 communication (The two CGND terminals are internally connected.)
⑪	ON/OFF interface		Remote ON/OFF signal
⑫	EtherCAT interface	LAN C/LAN D	Two, 100 Mbit/s. For LED status and description, see "2.4 LED Indicator" on page 18

2.3 LED Display

The LED display is shown in the following figures.



The meanings and descriptions of each icon are listed in the table below.

Icon	Meaning	Description
	CAN running	Steady green: Local CAN is running normally.
	CAN error	Flashing red: Local CAN error. You may locate the issue by checking the error code or diagnosis information.
	Warning	Steady yellow: User program running warning/System running warning.
	Fault	Steady red: User program running fault/System fault alarm.
	Running status	<ul style="list-style-type: none"> ● Flashing green: Device is being identified. ● Steady green: User program is running.
	SSD	Flashing white: Data read/write in progress.
	System identification	Flashing white: PLC identified.
	Fault code	For fault code meanings and troubleshooting, see " Appendix " on page 59
	CPU usage	One segment lit: $0\% < \text{CPU usage} \leq 10\%$ Two segments lit: $10\% < \text{CPU usage} \leq 30\%$ Three segments lit: $30\% < \text{CPU usage} \leq 60\%$ Four segments lit: $60\% < \text{CPU usage} \leq 90\%$ Five segments lit: $\text{CPU usage} > 90\%$

2.4 LED Indicator

The Ethernet and EtherCAT interfaces share the same LED indicator definitions, as detailed in the following table.

LED Name	Function	Status and Meaning
Green LED	Speed	<ul style="list-style-type: none"> ● Steady ON: Connected at 100/1000 Mbit/s ● OFF: 1. Connected at 10 Mbit/s; 2. Not connected
Orange LED	Link/Act	<ul style="list-style-type: none"> ● Steady ON: Connected ● Flashing: Connected with data transmission/reception ● OFF: Not connected

2.5 Technical Specifications

2.5.1 General

Item	Specification
CPU model	Intel Celeron®, J6000 series
Memory capacity	4 GB, LPDDR4X SDRAM, interface rate 3200 MT/s
Hard drive capacity	64 GB SSD
Hard drive type	M.2 2280 interface
BIOS	256 Mbit flash ROM, AMI BIOS
Bit instruction execution time	4.8 ns
Integer operation time	5.3 ns
Floating point operation (double precision)	13.2 ns
Programming mode	IEC 61131-3 programming languages (LD, ST)
Operating system	Linux Preempt-RT
Program execution mode	Compiled execution
User program storage	128 MB
User data storage	128 MB
Power failure detection threshold	17 V to 19.4 V
Charging time of the capacitor for data retention at power failure	20s
Time of retention at power failure	150 ms
Space of retention at power failure	5 MB, built-in, no external UPS required
EtherCAT communication	2 channels (each supports up to 128 slaves; total of 256 slaves for 2 channels)
Modbus TCP communication	2 channels (as master: supports up to 63 slaves; as slave: can be connected by up to 16 masters)

Item	Specification
Modbus RTU communication	9 channels (as master: each channel supports up to 31 slaves; as slave: can be connected by up to 1 master) <ul style="list-style-type: none"> ● Built-in: 1 channel ● Expansion: 8 channels (supports up to four GL20-2S485 modules)
EtherNet/IP communication	2 channels (maximum client connections: 64; maximum server connections: 64)
OPC UA communication	2 channels (supports up to 50 clients in total)
CANopen communication	9 channels <ul style="list-style-type: none"> ● Built-in: 1 channel, as master only; supports up to 8 slaves per channel ● Expansion: 8 channels (supports up to four GL20-2CAN modules)
FINS TCP/UDP communication	2 channels (each supports up to 32 connections)
MELSEC communication	2 channels (each supports up to 32 connections)
Maximum clock deviation	4s/day (room temperature)
Battery	CR2032 button battery (3 V; battery capacity \geq 210 mAh; ambient temperature: -40°C to $+85^{\circ}\text{C}$)
Heat dissipation mode	Natural convection, with internal heatsink
Expansion module	Supports up to 32 GL20-XX series local expansion modules (repeater power module required when more than 16 local expansion modules are connected)
Programming language	LD and ST; FB/FC supported (LD)
IP rating	IP20
Dimensions (W x H x D)	150 mm x 100 mm x 85 mm
Mass	Approx. 0.95 kg

2.5.2 Power Supply

Item	Specification
Rated terminal input voltage	24 VDC (-15% to +20%), non-isolated
Rated terminal input current	Maximum 4 A, typical 2.4 A; supplying power to the PLC and local expansion modules
Surge current ^[1]	≤ 10 A for ≤ 2 ms at cold start under normal temperature
Rated bus output voltage	5.2 VDC (4.75 VDC to 5.5 VDC)
Rated bus output current	2 A (maximum at 5.2 V)
Bus 5 V output power protection	Short-circuit protection supported
24 V input power protection	Short-circuit protection and reverse polarity protection supported
Module hot-swap	Not supported

[1]: Surge current at power-on. The surge current may vary depending on the operating conditions. When selecting fuses, circuit breakers, or external power supply devices, choose products with appropriate characteristics and sufficient capacity based on the operating conditions. In particular, if ON/OFF operations are performed by inserting a switch into the DC power supply line from an external source, a surge current of approximately 50 A for 0.1 ms may occur during an ON-OFF-ON cycle within 1 second.

2.5.3 Ethernet

Item	Specification
Number of channels	2
Network medium	Cat 5e cable; for details, see "4.2 Preparing Cables" on page 37
Duplex mode	Full duplex
Network interface	RJ45 (with metal housing and LED indicator)
Baud rate	10/100/1000 Mbit/s
Communication distance	≤ 100 m

2.5.4 OPC UA

Item	Specification
Security policy	-
User authentication	Anonymous
Server port	4840
Session timeout (s)	5 to 600,000; default: 30
Sampling interval (ms)	100, 300, 500, 1000, 2500, 5000; default 100
Minimum publishing interval (ms)	200 to 20,000,000; default: 1000
Maximum number of sessions	50
Maximum number of subscriptions per server	200
Maximum number of monitored nodes per server	20,000
Maximum number of subscriptions per session	50
Maximum number of monitored nodes per subscription	10,000
Maximum number of nodes per read/write in a single frame	1000

2.5.5 RS485

Item	Specification
Number of channels	9 <ul style="list-style-type: none">• Built-in: 1 channel• Expansion: 8 channels (supports up to four GL20-2S485 modules)
Isolation method	Digital isolator
Termination resistor	Yes (no termination resistor for expansion modules)

Item	Specification
Master/Slave	Supports master or slave mode
Number of slaves	Supports up to 31 slaves (distance of each slave branch line < 3 m)
Protocol	Supports the Modbus RTU protocol and free protocol
Communication rate	4.8/9.6/19.2/38.4/57.6/115.2 kbit/s

2.5.6 CAN

Item	Specification
Number of channels	9 channels <ul style="list-style-type: none"> ● Built-in: 1 channel ● Expansion: 8 channels (supports up to four GL20-2CAN modules)
Isolation method	Digital isolator
Termination resistor	Yes (termination resistor for expansion modules)
Master/Slave	Supports master mode only
Number of slaves	Supports up to 8 slaves
Protocol	Supports CANopen protocol and CAN free protocol
Communication rate	10/20/50/100/125/250/500/800/1000 kbit/s; default: 500 kbit/s

2.5.7 EtherCAT

Item	Specification
Number of channels	2
Communication protocol	EtherCAT protocol
Services supported	FoE, CoE (PDO, SDO)
Minimum sync period	<ul style="list-style-type: none"> ● 250 μs: 8 axes (supports up to 8 axes) ● 500 μs: 32 axes (supports up to 32 axes) ● 1 ms: 64 axes (supports up to 64 axes) ● 4 ms: 96 axes (point-to-point control)
Maximum EtherCAT task jitter	$\pm 40 \mu$ s

Item	Specification
Maximum synchronization jitter between EtherCAT slaves	1 μ s
Maximum number of axes	<ul style="list-style-type: none"> ● AM763-INT: 32 ● AM764-INT: 64 ● AM765-INT: 96
Synchronization mode	Servo: Distributed clock (DC); I/O: Input/Output synchronization
Physical layer	100BASE-TX
Baud rate	100 Mbit/s (100Base-TX)
Duplex mode	Full duplex
Topology	Ring and linear
Transmission medium	Cat 5e cable; for details, see "4.2 Preparing Cables" on page 37
Transmission distance	< 100 m between two nodes
Number of slaves	Maximum 256 (Each EtherCAT channel supports up to 128 slaves.)
EtherCAT frame length	44 bytes to 1498 bytes
Process data	Maximum 1486 bytes per Ethernet frame
DLR function	Supported
Automatic scanning	Supported

2.5.8 USB

Item	Specification
Number of channels	4 (USB 2.0: 2; USB 3.0: 2)
Communication rate	<ul style="list-style-type: none"> ● USB 2.0: Up to 480 Mbit/s ● USB 3.0: Up to 5.0 Gbit/s
5 V output current	<ul style="list-style-type: none"> ● USB 2.0: Maximum 500 mA per channel (no current limit), maximum 1000 mA for both channels ● USB 3.0: Maximum 900 mA per channel (no current limit), maximum 1800 mA for both channels
Communication distance	<ul style="list-style-type: none"> ● USB 2.0: Maximum 5 m ● USB 3.0: Maximum 3 m

Item	Specification
Isolation	No
USB short-circuit protection	Yes
USB communication version	<ul style="list-style-type: none"> ● USB 2.0, full-speed mode ● USB 3.0
USB hardware interface	USB 2.0/3.0: Type A
Host/Device	Host
Power supply	Supported <ul style="list-style-type: none"> ● USB 2.0: 5 V, 0.5 A ● USB 3.0: 5 V, 0.9 A

2.5.9 Type-C

Item	Specification
Number of channels	1, for commissioning use
USB cable length	1.5 m
USB communication version	USB 2.0
Hardware interface	Standard Type-C receptacle
Host/Device	Device
Power supply	Not supported

3 Installation

3.1 Preparation

3.1.1 Installation Environment Requirements

When installing the controller on the guide rail, take the operability, maintainability, and robustness into account.

Item	Specification
Operating environment	No corrosive and flammable gas and no excessive conductive dust
Altitude	≤ 4000 m
Pollution degree	2
Immunity	4 kV on power supply cable (compliant with IEC 61000-4-4)
Overvoltage category	I
Overcurrent protection device	4 A fuse
EMC immunity level	Zone B, IEC 61131-2
Vibration resistance	<ul style="list-style-type: none">● Operating: Sinusoidal vibration test per IEC 60068-2-6. Test conditions: 5 Hz to 8.4 Hz, 3.5 mm amplitude; 8.4 Hz to 200 Hz, 1 · g amplitude; X/Y/Z axes, 10 cycles per axis.● Transportation: Random vibration test per IEC 60068-2-64. Test conditions: 5 Hz to 100 Hz, $0.01 \cdot g^2/\text{Hz}$; 200 Hz, $0.001 \cdot g^2/\text{Hz}$; $G_{\text{rms}} = 1.14 \cdot g$; X/Y/Z axes, 30 min per axis.
Shock resistance	<ul style="list-style-type: none">● Operating: Shock test per IEC 60068-2-27. Test conditions: 15 · g peak acceleration, 11 ms pulse width, total 18 shocks across three axes.● Transportation: Shock test per IEC 60068-2-27. Test conditions: 15 · g peak acceleration, 11 ms pulse width, total 18 shocks across three axes.
Noise immunity	Noise voltage: 3000 Vp-p; Noise width: 50/300/700/1000 ns; Frequency: 60 Hz; Duration: 1 min

Item	Specification
Impact resistance	100 m/s ² , 16 ms; ±X/Y/Z axes; 1000 cycles per direction, totaling 6000 cycles
Ambient temperature and humidity	<ul style="list-style-type: none"> • Temperature: -5°C to +55°C • Humidity: 10% RH to 95% RH, non-condensing
Storage temperature and humidity	<ul style="list-style-type: none"> • Temperature: -20°C to +60°C • Relative humidity: < 95% RH, non-condensing

3.1.2 Installation Position Requirements

This product supports horizontal installation only, as shown in the following figure.

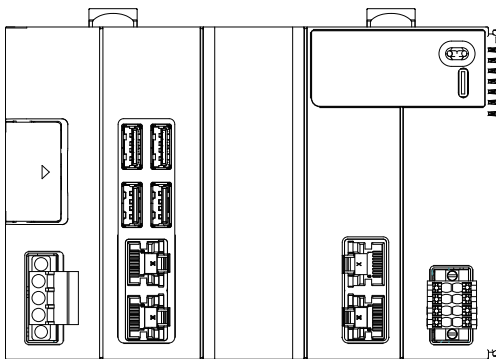
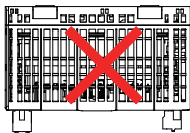
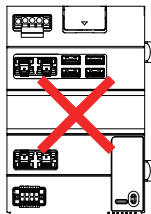

Figure 3-1 Correct installation position

Any other mounting orientation is incorrect, as illustrated in the following figure.



Top of the cabinet



Vertical orientation 2

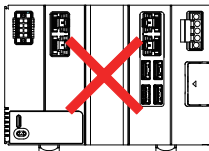

Horizontal inverted

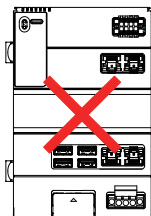

Vertical orientation 1

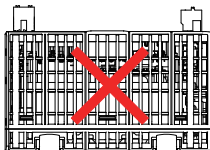

Bottom of the cabinet

This product is cooled by natural convection. To ensure proper ventilation and sufficient wiring space, maintain a minimum clearance A of > 50 mm around the unit, as shown in the following figure.

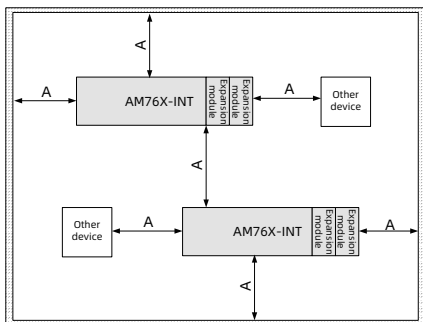

Figure 3-2 Minimum clearance

3.1.3 Preparing the Product and Tools

Before installation, verify that all required items and tools are available.

Item	Description
AM76X-INT PLC (with end cover)	At least one unit
Standard DIN rail	At least one set, compliant with IEC 60715 (to be prepared by customer)
Guide rail end plate	At least one pair
Screw	Standard DIN rail mounting (M5, to be prepared by customer)
Screwdriver	One straight screwdriver ($\phi 2.5$ mm) and one Phillips screwdriver ($\phi 5$ mm)

3.1.4 Knowing the Installation Dimensions

■ PLC

Dimensions of the PLC are shown in the following figure (unit: mm).

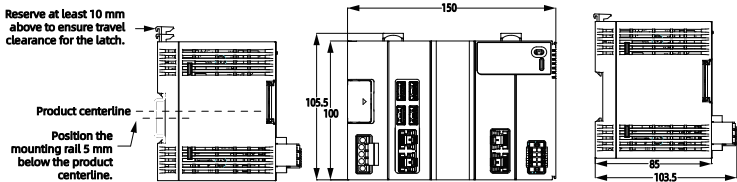

Figure 3-3 Dimensions of the PLC

■ PLC with cables

Dimensions of the PLC with cables are shown in the following figure (unit: mm).

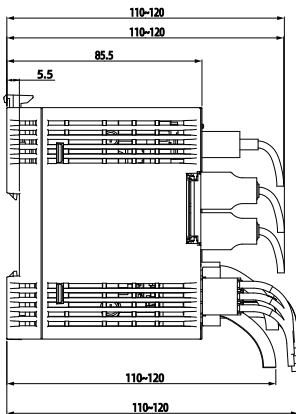

Figure 3-4 Dimensions of the PLC with cables

■ End cover

Dimensions of the end cover are shown in the following figure (unit: mm).

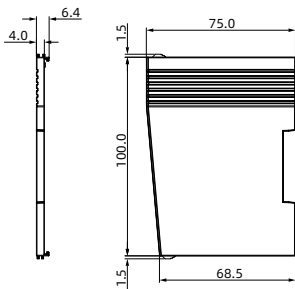

Figure 3-5 Dimensions of the end cover

■ DIN rail

The DIN rail must comply with IEC 60715 (35 mm width, 1 mm thickness). Dimensions are shown in the following figure (unit: mm).

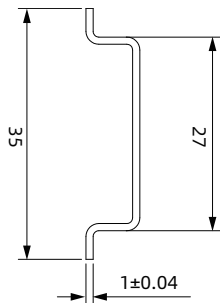

Figure 3-6 Dimensions of the rail

3.2 Installation Precautions

- Ensure the product is completely disconnected from the power supply before installation.
- Do not drop or strike on the product enclosure, terminal blocks, or connectors to avoid damage.
- Do not disassemble the product, as this may cause damage.

- Do not overtighten screws or fasteners to avoid damaging the product or terminals.

3.3 Installation Procedure

1. Install the PLC.

Align the PLC with the DIN rail and press it in the direction shown by the arrow until it snaps into place with a distinct click, as shown in the following figure.

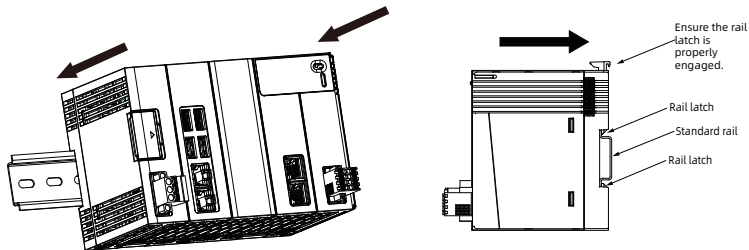

Figure 3-7 Installing the PLC

Note

After installation, the latches should automatically spring back to secure the PLC onto the rail. If they do not, press down on the top of the latches by hand to ensure proper engagement.

2. Install modules.

- a. Before installing modules, remove the end cover in the direction shown by the arrow, as shown in the following figure.

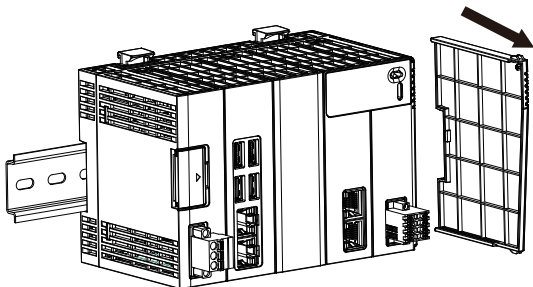

Figure 3-8 Removing the end cover

- b. Slide each module along the top and bottom guide rails on the module to mount it. After all modules are installed, attach the end cover at the far right, as shown in the following figure.

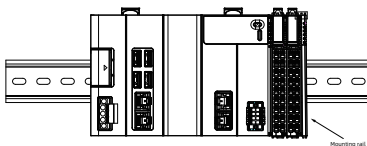
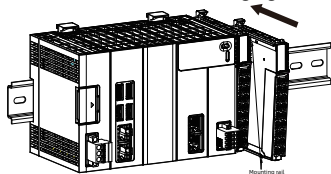

Figure 3-9 Installing modules and the end cover

3. Install the guide rail end plates.

Install one end plate at each end. Hook the bottom of the end plate onto the lower edge of the DIN rail, then rotate it upward so that the top engages with the upper edge of the DIN rail. Finally, tighten the screw to lock the end plate in place, as shown in the following figure.

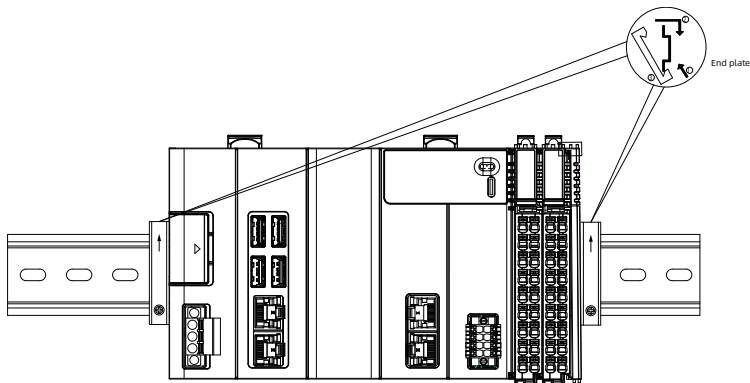

Figure 3-10 Installing guide rail end plates

3.4 Post-installation Check

1. Check that the DIN rail latches are fully engaged.
2. Check that both guide rail end plates are securely fastened.
3. Check that all terminal screws are properly tightened.

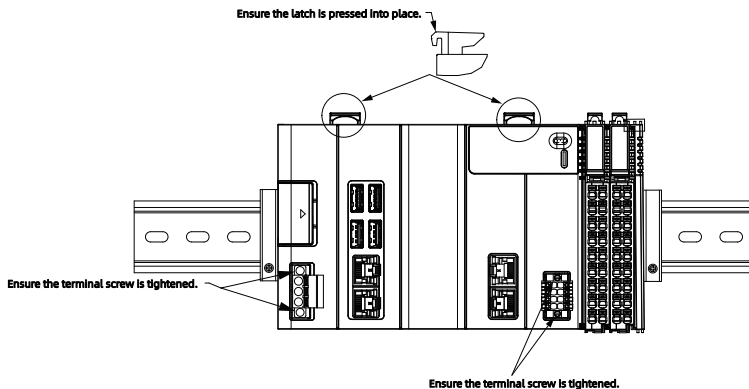

Figure 3-11 Post-installation check

4 Cable Connection

4.1 Wiring Requirements

4.1.1 Grounding Requirements

■ PLC grounding

A grounding terminal is provided on the PLC power supply connector. Use a grounding wire that is as short and thick as possible (≤ 30 cm) to ground the PLC.

■ Shielded cable grounding

Communication signal cables must be shielded. Ground the shielded cable as close to the controller as possible so that the cable is not interfered with by electromagnetic induction. The exposed shielded cable must touch the grounding point as much as possible to ensure good contact.

Do not solder a PVC-insulated wire to the shielded cable for grounding because this will increase the high frequency impedance and attenuate the shielding effect. Communication cables must be grounded at both ends.

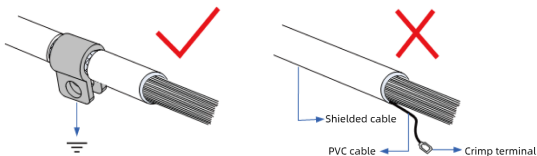

Figure 4-1 Shielded cable grounding requirements

4.1.2 Routing Requirements

Low-voltage cables (< 1 kV) are generally classified into four categories. Only cables of the same category may be bundled together. Cables of different categories must be routed separately and should generally not cross or overlap. When crossing is unavoidable, maintain a 90° angle at the intersection.

No.	Category	Application
1	Category 1	Ethernet and EtherCAT ports
2	Category 2	Low-speed digital communication signals (RS232 and RS485) and digital I/O signals
3	Category 3	Low-voltage AC power distribution cables or DC power cables (such as 24 VDC output cables of switched-mode power supplies)
4	Category 4	Input and output cables, welding machine cables, and power cables for power converters

Keep a proper distance between different categories of cables. For cables shorter than 30 m, the minimum distance allowed is shown in the following figure.

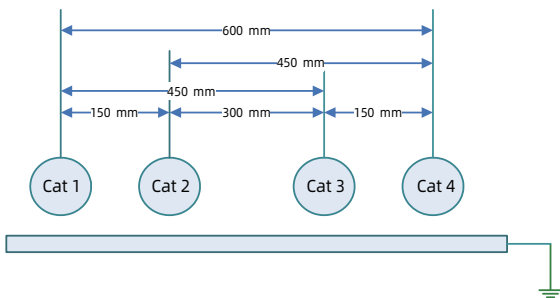

Figure 4-2 Required distances between different categories of cables

Note

- If two cables run parallel for an extended length, increase the distances accordingly.
- You can also install spliced shielding plates between different categories of cables. To reduce cross interference, route all cables as closely as possible to the grounded structural components of the cabinet, such as the cabinet's mounting plate or rack components.

4.1.3 Power Filter Requirements (Optional)

When the PLC is used in environments with strong interference sources (such as an AC drive), it is recommended that you add a noise filter to suppress the interference.

Install the filter as close as possible to the power supply of the PLC. Secure the filter with screws to the conductive backplane. Protect the area around the screws with paint and ensure reliable grounding. The outgoing and incoming cables of the filter should be routed separately to avoid noise coupling on the cables.

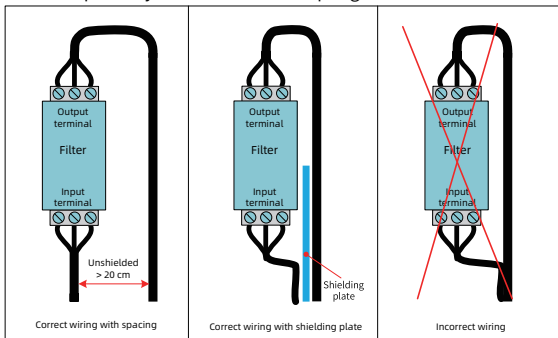

4.2 Preparing Cables

■ Power/Communication cables

See the following table for power/communication cable specifications. Cable lugs and wire gauges are for reference only. Select proper cables based on actual situations.

Component	Applicable Wire Gauge		Strip Length	XIMENKAN	
	mm ²	AWG		Model	Crimping Tool
Tubular lug	0.5	22	10 mm to 11 mm	ENY0510	CRIMPFOX6
	0.75	20	10 mm to 11 mm	ENY7510	
	1.0	18	10 mm to 11 mm	ENY1010	

■ Network cables

Ethernet/EtherCAT communication has strict requirements on cables. Use shielded Cat 5e or higher-specification network cables that meet the following requirements.

● Cable requirements

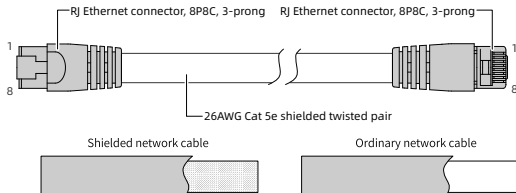

● Length requirements

For EtherCAT bus communication, the cable length between devices must not exceed 100 m. Exceeding this limit may cause signal attenuation and affect normal communication.

● Technical requirements

Cables must pass 100% continuity testing with no shorts, opens, miswiring, or poor contacts. The following specifications are recommended:

Item	Specification
Cable type	Flexible crossover cable, S-FTP, Cat 5e
Compliance	EIA/TIA568A, EN 50173, ISO/IEC 11801 EIA/TI Abulletin TSB, EIA/TIA SB40-A&TSB36
Conductor gauge	AWG26
Conductor type	Twisted pair
Number of pairs	4

● Pin assignment

Pin	Signal (Ethernet 1000 Mbit/s)	Signal Direction	Description
1	TD+	Output	Data transmission+
2	TD-	Output	Data transmission-
3	RD+	Input	Data reception+

Pin	Signal (Ethernet 1000 Mbit/s)	Signal Direction	Description
4	-(DC+*)	-(Bidirectional)	Not used (data C+)
5	-(DC-)	-(Bidirectional)	Not used (data C-)
6	RD-	Input	Data reception-
7	-(DD+)	-(Bidirectional)	Not used (data D+)
8	-(DD-)	-(Bidirectional)	Not used (data D-)

* The assignments of pins 4, 5, 7, and 8 at the Ethernet baud rate of 1000 Mbit/s differ from those at 100 Mbit/s.

4.3 Connecting the Power Cable

The 24 V input power terminal uses a push-in design for easy wiring.

Simply align the power cable with the 24 V input power terminal and insert it directly.

Note

To remove the power cable, press the orange release tab next to the 24 V input power terminal and pull the cable outward.

4.4 Connecting the Network Cable

The Ethernet and EtherCAT interfaces use RJ45 connectors for easy wiring.

Hold the Ethernet plug, align it with the Ethernet/EtherCAT interface, and insert it directly until it clicks into place.

Note

To remove the network cable, press the release tab on the Ethernet plug and pull the cable out horizontally.

4.5 Connecting the CAN Communication Cable

■ CAN communication network setup

When setting up a CAN network, connect the three wires of devices in a one-to-one correspondence. A 120 Ω termination resistor must be installed at each end of the CAN bus. The following figure shows an example of a CAN bus network topology using built-in termination resistors.

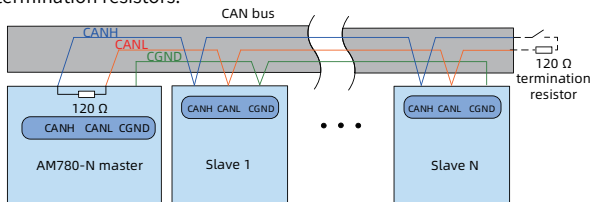

The following table lists the relationship between CAN communication distances and baud rates.

Baud Rate (kbit/s)	Communication Distance (m)
1000	20
500	80
250	150
125	300
100	500
50	1000

■ Cable connection

The CAN communication terminal uses a push-in design for easy wiring.

Simply align the communication cable with the CAN communication terminal and insert it directly.

Note

To remove the CAN communication cable, press the orange release tab next to the CAN communication terminal and pull the cable outward.

4.6 Connecting the RS485 Communication Cable

■ RS485 communication network setup

It is recommended to use a shielded twisted pair cable as the RS485 bus, and use twisted pair cables to connect the RS485+ and RS485- terminals. Connect a 120 Ω termination resistor to each end of the bus to prevent signal reflection. Connect the RS485 signal reference grounds of all nodes together. Up to 31 nodes can be connected and the cable length of any node branch must be less than 3 m.

The following figure shows an example of an RS485 bus network topology using built-in termination resistors.

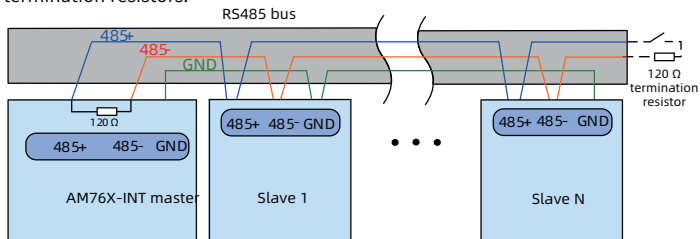

■ Cable connection

The RS485 communication terminal uses a push-in design for easy wiring.

Simply align the communication cable with the RS485 communication terminal and insert it directly.

Note

To remove the RS485 communication cable, press the orange release tab next to the RS485 communication terminal and pull the cable outward.

5 Power-On and Power-Off

5.1 Power-On

Prerequisites: The PLC has been powered off.

Procedure

The PLC can be powered on in either of the following ways.

- 24 V input power terminal not connected: After the 24 V input power is connected, the PLC powers on and starts automatically.
- 24 V input power terminal connected and the ON/OFF interface wired as shown in the following figure: Connect the remote ON/OFF signal circuit to the 24 V power supply for approximately 1 second and then disconnect it to power on and start the PLC (continuous connection will not power on the PLC).

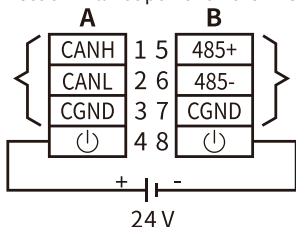

- Do not touch the terminals during power on. Failure to comply will result in an electric shock.
- Do not disassemble this product, especially during power on or shortly after power off, to prevent short circuits and other faults. In addition, sharp components and high temperatures inside the product may cause hazard to the human body.

5.2 Power-Off

Prerequisites: The PLC has been powered on.

Procedure

The PLC can be powered off in one of the following methods.

- Method 1: Directly disconnect the 24 V input power.
- Method 2: Enter the "shutdown" command in the Linux command line.
- Method 3 (when the ON/OFF interface is wired as shown in the following figure): Connect the remote ON/OFF signal circuit to the 24 V power supply for more than 5 seconds and then disconnect it (the PLC is powered off even if the remote ON/OFF signal circuit is not disconnected from the power supply, however, disconnection is recommended).

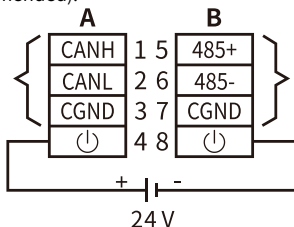

Caution

The product does not support rapid power-on and power-off cycles. After power-off, ensure an interval of at least 5 seconds before powering on again. Otherwise, the product may fail to start and require a power disconnection before restart.

6 Programming and Commissioning

For the programming and commissioning process, see the *Medium-Sized PLC Programming Software User Guide*, the *Medium-Sized PLC Programming Guide (Motion Control)*, and the *Medium-Sized PLC Instruction Guide*.

7 Maintenance

7.1 Routine Maintenance

Components of this product may age due to environmental conditions over time, therefore regular inspections are required. The recommended inspection interval is 6 to 12 months, and can be shortened according to the environment conditions. If any item does not meet the acceptance criteria, take corresponding actions.

No.	Item	Inspection	Acceptance Criteria	Action
1	Power supply	Measure at the power terminal block and check whether the voltage variation is within the allowable range.	24 VDC (-15% to +20%)	Use a multimeter to measure between terminals and adjust the power supply to keep the voltage variation within the allowable range.

No.	Item	Inspection	Acceptance Criteria	Action
2	Ambient environment	Ambient temperature (When the PLC is in a cabinet, the temperature in the cabinet is considered the ambient temperature.)	-5°C to +55°C	Use a thermometer to measure the ambient temperature and adjust the environment to keep the ambient temperature within the range of -5°C to +55°C.
		Ambient humidity (When the PLC is in a cabinet, the humidity in the cabinet is considered the ambient humidity.)	10% to 95% RH (non-condensing)	Use a hygrometer to measure the ambient humidity and adjust the environment to keep the ambient humidity within the range of 10% to 95% RH. Check for condensation if temperature fluctuates drastically.
		Direct sunlight	Not allowed	Take shielding measures.
		Dust, dirt, salt, or iron filings	Not allowed	Clean and take shielding measures.
		Droplets of water, oil, or chemical splashes	Not allowed	Clean and take shielding measures.
		Corrosive or flammable gases	Not allowed	Use an odor or gas sensor for detection.
		Vibration or shock to the PLC	Within the vibration and shock resistance specifications	Install cushioning materials for vibration and shock resistance.
		Interference sources	Not allowed	Keep the PLC away from any interference sources or take shielding measures.

No.	Item	Inspection	Acceptance Criteria	Action
3	Installation and wiring	Check whether the cable connectors are fully inserted and locked.	No looseness	Fully insert the connectors and lock them with screws.
		Check whether external wiring screws are loose.	No looseness	Tighten the screws with a Phillips screwdriver.
		Check whether the crimp terminals for external wiring are too close together.	Maintain proper spacing.	Visually inspect and correct.
		Check whether external wiring cables are about to break.	No visible abnormality	Visually inspect and replace cables (as needed).
4	Real-time clock battery (button battery)	Check whether the shelf life or service life has expired.	Battery service life: three years	It is recommended to replace the battery every three years. For replacement method, see "7.3 Battery Maintenance" on page 49

7.2 PLC or Module Maintenance

If the PLC or any module needs to be replaced due to damage or other issues, ensure the PLC and all modules are powered off before proceeding.

1. Remove the PLC or module.

- a. Pry up the rail latch with a Phillips screwdriver or similar tool.
- b. Pull the PLC or module away from the rail, and then press down on the top of the latch.

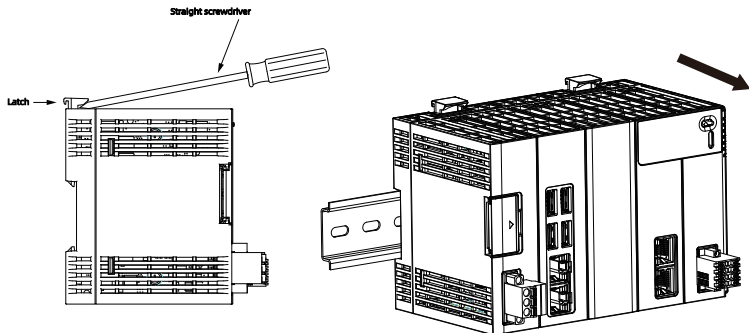

Figure 7-1 Removing the PLC or module

2. Install a new PLC or module. For detailed instructions, see steps 2 to 4 in ["3.3 Installation Procedure" on page 32](#).

7.3 Battery Maintenance

The battery is used for the real-time clock (RTC) timing inside the PLC and for retaining BIOS CMOS data when the power is off. If no battery is installed or the battery is depleted, the clock will stop timing and BIOS CMOS data will be lost when the power is off, restoring to factory default settings.

To ensure normal clock function of the PLC, it is recommended to replace the battery every three years. For battery specifications, see ["2.5.1 General" on page 19](#).



Replacing the battery may cause the RTC clock to stop timing and restore to factory default settings.

1. Disconnect the PLC power supply.
2. Remove the battery.
 - a. Open the battery cover with your finger.
 - b. Pry out the battery drawer with a straight screwdriver and remove the battery.

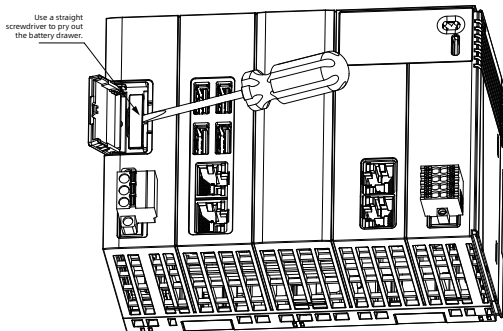

Figure 7-2 Removing the battery

3. Install a new battery.

- a. Place a new battery into the battery drawer and gently push the battery drawer into the battery compartment.



Do not reverse the battery polarity. When placing the battery into the drawer, ensure the positive side faces up. When pushing the drawer into the compartment, ensure the positive side faces left.

- b. Close the battery cover.

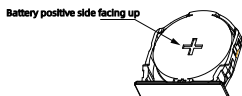
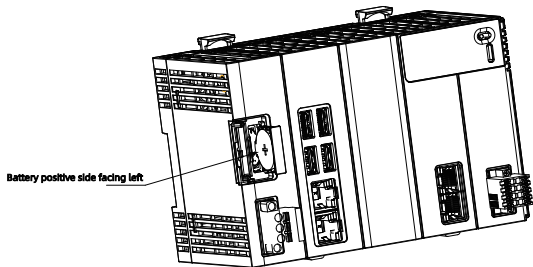
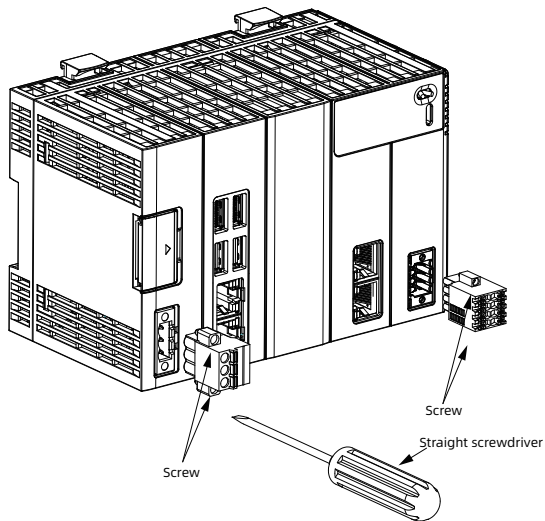

Figure 7-3 Installing a new battery

7.4 Terminal Maintenance

The power terminal and communication terminal are pluggable. If damaged, they can be replaced while the product is powered off.



1. Use a straight screwdriver ($\phi 2.5$ mm) to loosen the screws on both sides of the terminal.
2. Pull out the terminal with two fingers.
3. Align a new terminal with the socket and insert the new terminal.
4. Use a straight screwdriver to tighten the screws on both sides of the new terminal.

7.5 Firmware Upgrade

7.5.1 Upgrade Through USB Flash Disk



Caution

- Do not modify the name of the PLC firmware upgrade package.
 - The PLC firmware upgrade package must be placed in the root directory of the USB flash disk, not in any subdirectory.
 - Do not remove the USB flash disk before the firmware upgrade is complete.
 - Do not power off the PLC during the firmware upgrade.
-

Prerequisites:

- A reputable brand USB flash disk is prepared.
 - The firmware upgrade package has been obtained from Inovance technicians.
 - The PLC is running normally.
1. Copy the PLC firmware upgrade package to the root directory of the USB flash disk. Insert the USB flash disk into the PLC USB port and wait for the automatic upgrade to begin.
The PLC will automatically restart after the upgrade is complete.
 2. Remove the USB flash disk after the restart is complete.

7.5.2 Upgrade Through InoProShop



Caution

- Do not modify the name of the PLC firmware upgrade package.
 - Do not power off the PLC during the firmware upgrade.
-

Prerequisites:

- The firmware upgrade package has been obtained from Inovance technicians.

- The PLC is running normally.

1. On the InoProShop main screen, select Tools > InoProShop Tool to open the "InoProShop Tool" window, as shown in the following figure.

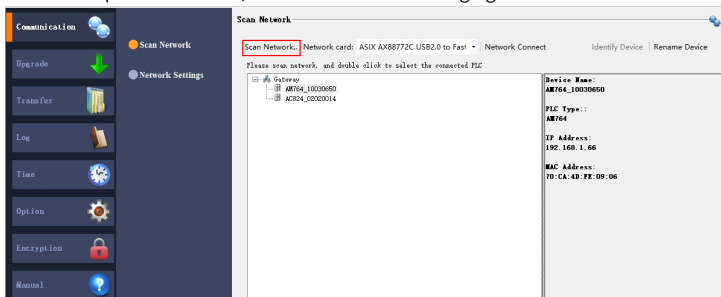

2. Click "Scan Network" and select the AM76X-INT device.

3. Select "Upgrade" to enter the "Upgrade" screen, as shown in the following figure.

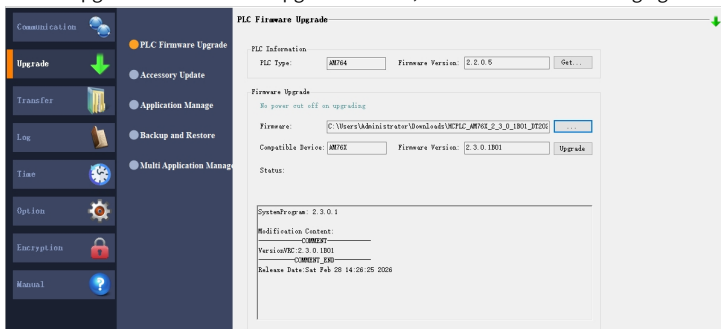

4. Click "Select" and select the firmware upgrade package saved locally.

5. Click "Upgrade".

The upgrade process will take several minutes. After the upgrade is complete, the AM76X-INT device will restart and a message box will appear, promoting "upgrade successful".

- Click "Get PLC Information" to retrieve the firmware version information again and check whether the upgrade was successful.

7.6 User Program Upgrade

7.6.1 Upgrade Through USB Flash Disk

This section describes how to upgrade the user program using a USB flash disk. For user program upgrade through online downloads, see the "Medium-Sized PLC Programming Software User Guide".



Caution

- Do not modify the name of the user program package.
- The user program package must be placed in the root directory of the USB flash disk, not in any subdirectory.
- Do not remove the USB flash disk before the user program upgrade is complete.
- Do not power off the PLC during the user program upgrade.

Prerequisites:

- A reputable brand USB flash disk is prepared.
 - The PLC is running normally.
- In the InoProShop menu bar, select Build > Pack Boot Project to open the "User program packager" dialog box, as shown in the following figure.

User program packager [-] [□] [×]

PLC Type: Runtime Version:

Firmware Version: 1.7.0.0 and later Init On Upgrade: ▾

Project: Application:

Company: Author:

Version:

Remarks:

2. Set the parameters and click "Pack" to save the user program package locally.

Parameter	Description
Init On Upgrade	<ul style="list-style-type: none"> • No: Retain retentive data after upgrade. • Yes: Initialize retentive data after upgrade.

3. Copy the user program package to the root directory of the USB flash disk. Insert the USB flash disk into the PLC USB port and wait for the automatic upgrade to begin.

The PLC will automatically restart after the upgrade is complete.

4. Remove the USB flash disk after the restart is complete.

7.7 Restoring and Obtaining the IP Address

7.7.1 Restoring the PLC IP Address to Default

If the PLC IP address is unknown, you can restore it to the default using a USB flash disk (default IP address of LAN A port: 192.168.1.88; default IP address of LAN B port: 192.168.2.88).



Caution

This operation takes effect only when the PLC is running normally.

Prerequisites: A reputable brand USB flash disk is prepared.

1. Format the USB flash disk to FAT32 or NTFS. Create an empty file named "network.default" in the root directory of the USB flash disk.
2. Insert the USB flash disk into the PLC. Wait approximately 1 to 2 minutes. The PLC IP address will be restored to the factory default.

After restoring the default IP address, you can scan and modify the IP address by connecting directly to the LAN A or LAN B port and navigating to Tools > InoProShop Tool in the InoProShop software.

7.7.2 Obtaining the PLC IP Address

If the PLC IP address is unknown, you can obtain it using a USB flash disk or InoProShop Tool.



Caution

This operation takes effect only when the PLC is running normally.

■ Through USB flash disk

Prerequisites: A reputable brand USB flash disk is prepared.

1. Format the USB flash disk to FAT32 or NTFS. Create an empty file named "network.info" in the root directory of the USB flash disk.

2. Insert the USB flash disk into the PLC. Wait approximately 30 seconds. The PLC IP information will be output to the "network.info" file. Read the file contents to obtain the PLC IP address.

■ Through InoProShop Tool

In the InoProShop menu bar, select Tools > InoProShop Tool to open InoProShop Tool. Click "Manual" and refer to the help manual to obtain the PLC IP address by scanning the network.

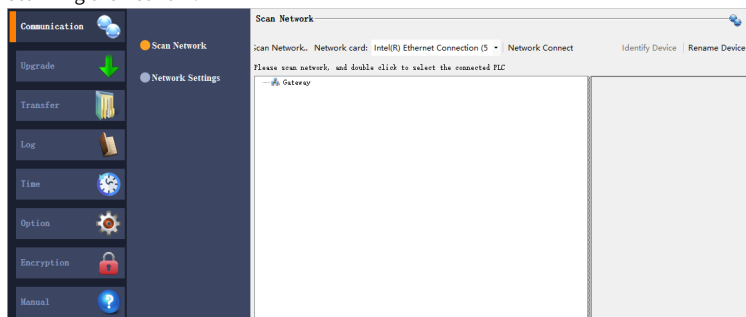

8 Appendixes

8.1 Appendix 1: Process Codes and Fault Codes During BIOS Startup

BIOS process and fault code IDs are independent of and do not conflict with other fault code IDs of this product. These IDs are shown on the LED display using the last two "88" segments, as illustrated below.

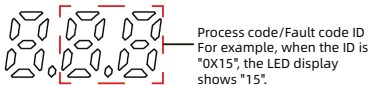

For BIOS process and fault code IDs along with their meanings, see the following table. In the event of a BIOS fault, contact Inovance for diagnosis and resolution.

BIOS Code ID	Meaning
Process Code	
0x15	Pre-memory North Bridge initialization is started
0x19	Pre-memory South Bridge initialization is started
0x32	CPU post-memory initialization is started
0x4F	DXE IPL is started
0x60	DXE Core is started
0x61	NVRAM initialization
0x62	Installation of the South Bridge Runtime Services
0x69	North Bridge DXE initialization is started
0x70	South Bridge DXE initialization is started
0x72	South Bridge devices initialization
0x78	ACPI module initialization
0x90	Boot Device Selection (BDS) phase is started
0x91	Driver connecting is started
0x92	PCI Bus initialization is started
0x93	PCI Bus Hot Plug Controller Initialization
0x94	PCI Bus Enumeration

BIOS Code ID	Meaning
0x95	PCI Bus Request Resources
0x96	PCI Bus Assign Resources
0x97	Console Output devices connect
0x98	Console input devices connect
0x9A	USB initialization is started
0x9C	USB Detect
0x9D	USB Enable
0xA0	IDE initialization is started
0xA2	IDE Detect
0xAD	Ready To Boot event
0xB2	Legacy Option ROM Initialization
0xB4	USB hot plug
Fault Code	
0x0E	Microcode not found
0x0F	Microcode not loaded
0x50	Memory initialization error. Invalid memory type or incompatible memory speed
0x51	Memory initialization error. SPD reading has failed
0x52	Memory initialization error. Invalid memory size or memory modules do not match
0x2C	PEI_MEMORY_PRESENCE_DETECT
	Note: If the buzzer keeps sounding during startup, it indicates an abnormal memory module installation, no available memory detected, or no memory installed. Contact Inovance for diagnosis and resolution.
0x54	Unspecified memory initialization error
0x55	Memory not installed
0x56	Invalid CPU type or Speed
0x57	CPU mismatch
0x58	CPU self test failed or possible CPU cache error
0x59	CPU micro-code is not found or micro-code update is failed

BIOS Code ID	Meaning
0x5A	Internal CPU error
0x5B	reset PPI is not available
0x5C	PEI phase BMC self-test failure
0xAB	Setup Input Wait
0xD0	CPU initialization error
0xD1	North Bridge initialization error
0xD2	South Bridge initialization error
0xD3	Some of the Architectural Protocols are not available
0xD4	PCI resource allocation error. Out of Resources
0xD5	No Space for Legacy Option ROM
0xD6	No Console Output Devices are found
0xD7	No Console Input Devices are found
0xD8	Invalid password
0xD9	Error loading Boot Option (LoadImage returned error)
0xDA	Boot Option is failed (StartImage returned error)
0xDB	Flash update is failed
0xDC	Reset protocol is not available
0xDD	DXE phase BMC self-test failure
0xE8	S3 Resume Failed
0xE9	S3 Resume PPI not Found
0xEA	S3 Resume Boot Script Error
0xEB	S3 OS Wake Error
0xF8	Recovery PPI is not available
0xF9	Recovery capsule is not found
0xFA	Invalid recovery capsule
0xA1	Failed to switch BIOS to OS
0XA2	No BIOS data was received

8.2 Appendix 2: PLC Function Fault Codes

PLC function fault code IDs are independent of other fault code IDs of this product. These IDs are shown on the LED display using the last two "88" segments, as illustrated below.

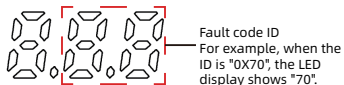

■ FPGA fault codes

Fault Code ID	Description	Solution
dE1	FPGA watchdog timeout	<ul style="list-style-type: none">● If the PLC can be pinged using the "ping+space+controller IP address" command and the version is earlier than 1.10.27.0, it is recommended to upgrade the firmware.● If the PLC cannot be pinged using the "ping+space+controller IP address" command, stop the PLC program through external I/O and download the application again.

■ Runtime fault codes

For runtime fault codes, their meanings, and solutions, see the following table.

Fault Code ID	Description	Solution
0x70	Modbus RTU0: Slave address setting error	Set a valid slave address.
0x71	Modbus RTU0: Frame length error	Modify the data frame.
0x72	Modbus RTU0: Illegal data address	Change to a valid data address.
0x73	Modbus RTU0: CRC check failed	<ol style="list-style-type: none">1. Check whether the termination resistor setting is appropriate.2. Optimize wiring, such as eliminating potential interference sources.

Fault Code ID	Description	Solution
0x74	Modbus RTU0: Illegal function	Check the slave commands.
0x75	Modbus RTU0: Communication time out	<ol style="list-style-type: none"> 1. Check whether the slave is operating normally. 2. Check whether the wiring is disconnected. 3. Check whether the termination resistor setting is appropriate. 4. Optimize wiring, such as eliminating potential interference sources.
0x76	Modbus RTU0: Illegal data value	Check the range of data written to the slave.
0x77	Modbus RTU0: Buffer overflow	Check the range of data written to the slave.
0x78	Modbus RTU0: Server device failure	Check the slave communication device.
0x79	Modbus RTU0: Serial port setting error	Check whether the communication configuration is correct.
0x80	Modbus RTU1: Slave address setting error	Set a valid slave address.
0x81	Modbus RTU1: Frame length error	Modify the data frame.
0x82	Modbus RTU1: Illegal data address	Change to a valid data address.
0x83	Modbus RTU1: CRC check failed	<ol style="list-style-type: none"> 1. Check whether the termination resistor setting is appropriate. 2. Optimize wiring, such as eliminating potential interference sources.
0x84	Modbus RTU1: Illegal function	Check the slave commands.

Fault Code ID	Description	Solution
0x85	Modbus RTU1: Communication time out	<ol style="list-style-type: none"> 1. Check whether the slave is operating normally. 2. Check whether the wiring is disconnected. 3. Check whether the termination resistor setting is appropriate. 4. Optimize wiring, such as eliminating potential interference sources.
0x86	Modbus RTU1: Illegal data value	Check the range of data written to the slave.
0x87	Modbus RTU1: Buffer overflow	Reduce the communication load.
0x88	Modbus RTU1: Server device failure	Check the slave communication device.
0x89	Modbus RTU1: Serial port setting error	Check whether the communication configuration is correct.
Ethernet (Modbus TCP)		
0x90	Modbus TCP: Slave address setting error	Set a valid slave address.
0x91	Modbus TCP: Frame length error	Modify the data frame.
0x92	Modbus TCP: Illegal data address	Change to a valid data address.
0x93	Modbus TCP: CRC check failed	<ol style="list-style-type: none"> 1. Check whether the termination resistor setting is appropriate. 2. Optimize wiring, such as eliminating potential interference sources.
0x94	Modbus TCP: Illegal function	Check the slave commands.

Fault Code ID	Description	Solution
0x95	Modbus TCP: Communication time out	<ol style="list-style-type: none"> 1. Check whether the slave is operating normally. 2. Check whether the wiring is disconnected. 3. Check whether the termination resistor setting is appropriate. 4. Optimize wiring, such as eliminating potential interference sources.
0x96	Modbus TCP: Illegal data value	Check the range of data written to the slave.
0x97	Modbus TCP: Buffer overflow	Reduce the communication load.
0x98	Modbus TCP: Server device failure	Check the slave communication device.
0x9A	Modbus TCP: Destination XX is unreachable	<ol style="list-style-type: none"> 1. Check whether the slave is operating normally. 2. Check whether the wiring is disconnected. 3. Check whether the master hardware is operating normally. 4. Optimize wiring, such as eliminating potential interference sources.
0x9B	Modbus TCP: Protocol identifier error	Check the protocol identifier.
CPU Faults		
0x21	System:Runtime crashed	<ol style="list-style-type: none"> 1. Restart the PLC. 2. Contact the agent or Inovance.
0x22	System:Comm.Timeout between PLC & LCD Panel	<ol style="list-style-type: none"> 1. Restart the PLC. 2. Contact the agent or Inovance.

Fault Code ID	Description	Solution
0x24	Battery voltage is too low or battery is in reverse	Replace the battery or check for installation errors.
0x25	Fan is broken or not installed	Check the fan for faults.
0x26	The communication between daemon process and application program operation environment times out	<ol style="list-style-type: none"> 1. Correct the application, restart the PLC, and download and execute the program again. 2. Obtain application run logs through the diagnostic window. 3. Collect log information through InoProShop Tool and send it for analysis.
0x27	Application exception!	Check and update the application.
0x28	Load bootproject fail!	Exception occurred while loading the boot project.
0x2E	ProcessorLoad exception	Check the application task configuration.
0x2F	Network open failed	<ol style="list-style-type: none"> 1. Restart the PLC. 2. Contact the agent or Inovance.
Permission Faults		
0x23	Authentication failed, please contact the supplier!	<ol style="list-style-type: none"> 1. Restart the PLC. 2. Contact the agent or Inovance.
Memory Faults		
0x31	Memory init fail	Return the device for repair.
Register Faults		
0x29	FPGA PCIE offline and online again	<ol style="list-style-type: none"> 1. Record the exception and provide feedback to Inovance developer team. 2. Perform on-site EMC analysis.

8.3 Appendix 3: EtherCAT Fault Codes

EtherCAT fault code IDs are independent of and do not conflict with other fault code IDs of this product. All the EtherCAT fault codes start with "E". These IDs are shown on the LED display in the following format.

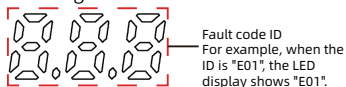

For EtherCAT fault code IDs, their meanings, and solutions, see the following table.

Fault Code ID	Description	Solution
E01	Master communication error: More than 100 consecutive frames lost	<ol style="list-style-type: none">1. Check whether the network cable connection between the master and slave is disconnected.2. Check whether the slave OUT port is connected correctly.3. Check whether the network cable connection is secure.4. Check whether the network cable connector is metal-shielded.5. Check whether the network cable meets Cat 5e standards.6. Check whether the device is properly grounded.7. On the master, set xRestart to TRUE to restart the bus.8. Power cycle the PLC and slave devices
E02	Some slaves offline: Number of online slaves does not match the configured number	Check whether the slave is powered off or whether the network cable is disconnected.
E03	DC clock error: Reference clock remains unchanged	Check whether the reference clock slave is offline.

Fault Code ID	Description	Solution
E04	Failed to open NIC	<ol style="list-style-type: none"> 1. Check the network port configuration. 2. Restart the PLC. 3. Replace the PLC.
E05	Failed to open redundant NIC	<ol style="list-style-type: none"> 1. Check the network port configuration. 2. Restart the PLC. 3. Replace the PLC.
E06	Failed to open redundant NIC: Same NIC configured for redundancy	<ol style="list-style-type: none"> 1. Restart the PLC. 2. Replace the PLC.
E07	Slave initialization error: Slave not present during startup, or communication cannot be established	<ol style="list-style-type: none"> 1. The network cable connection between the master and slave is disconnected. 2. The network cable connection between slaves is disconnected, has poor contact, or encounters a hardware failure. 3. The OUT port of one slave is connected to the OUT port of another slave. 4. Use the EtherCAT device scanning function to locate the faulty slave. 5. Power cycle all slaves and try again.

Fault Code ID	Description	Solution
E08	Vendor ID mismatch: Configured vendor ID does not match the actual one	<ol style="list-style-type: none"> 1. Use the EtherCAT device scanning function to compare the configuration with the scan results. 2. Power cycle the slave that the master failed to access.
E09	Product ID mismatch: Configured product ID does not match the actual one, or the master failed to read the product ID of this slave	<ol style="list-style-type: none"> 1. Use the EtherCAT device scanning function to compare the configuration with the scan results. 2. Power cycle the slave that the master failed to access.
E0A	Slave count mismatch: Number of configured slaves is greater than the actual number	Use the EtherCAT device scanning function to compare the configuration with the scan results and identify the differences.
E0B	SDO download failed	Refer to the slave device user guide to find the error cause and the solution in the "Return Error Code" section.
E0C	SDO download timeout	<ol style="list-style-type: none"> 1. Check the network connection status of the slave. 2. Check the user program: Reduce the scheduling frequency of SDO, EOE, and SOE function blocks to lower the communication load.
E0D	Slave emergency event error	Refer to the slave device user guide to find the error cause in the "Emergency Event Error Code", "Error Register", and "Manufacturer Custom Error Code" sections.

Fault Code ID	Description	Solution
E0E	SOE download failed	<ol style="list-style-type: none"> 1. Refer to the slave device user guide to find the error cause in the "Return Error Code" section. 2. Reconnect the slave to the network.
E0F	SOE download timeout	<ol style="list-style-type: none"> 1. Check the network connection status of the slave. 2. Check the user program: Reduce the number and frequency of SDO, EOE, and SOE function blocks.
E10	Master request state machine timeout	<ol style="list-style-type: none"> 1. On the EtherCAT master overview screen, check for slaves with a receive error counter value not equal to 0 and check the network cable connection status. 2. Check whether the device is properly grounded. 3. Restart the EtherCAT master. 4. Replace the slave device.
E20	Alias address conflict: Multiple slaves on the network have the same alias address enabled	On the EtherCAT device scanning screen, reconfigure the alias addresses of the conflicting slaves. The change takes effect after a power cycle following successful writing.
E21	Slave IN/OUT connection error	<ol style="list-style-type: none"> 1. A slave OUT port is connected to another slave OUT port. 2. A slave OUT port is connected to the master.
E22	EEPROM access failed: Master failed to access slave EEPROM during startup	Power cycle the slave.

Fault Code ID	Description	Solution
E30	Continuous frame loss fault	<ol style="list-style-type: none"> 1. Check whether the network cable is connected. 2. Replace the network cable. 3. Replace the slave device. 4. Add a magnetic ring or replace the network cable with a higher-specification one.
E31	Slave port link disconnected	<ol style="list-style-type: none"> 1. Check whether the network cable connection is secure. 2. Check whether the network cable is connected. 3. Replace the network cable.
E32	Occasional frame loss warning	<ol style="list-style-type: none"> 1. Replace the network cable. 2. Replace the slave or the previous slave. 3. Add a magnetic ring or replace the network cable with a higher-specification one.
E64	Failed to switch communication state	<ol style="list-style-type: none"> 1. Restart the PLC. 2. Contact the agent or Inovance.
E65	Unknown slave error	<ol style="list-style-type: none"> 1. Restart the PLC. 2. Contact the agent or Inovance.
E66	Slave mailbox memory allocation failed	<ol style="list-style-type: none"> 1. Restart the PLC. 2. Contact the agent or Inovance.
E6A	Firmware mismatch error: Slave firmware version does not match EEPROM-stored information	Replace the firmware program.
E6B	Slave firmware update failed	Check the sequence of master state machine transition requests. Skipping states to change the slave state machine is not allowed.

Fault Code ID	Description	Solution
E75	State machine error	Check the sequence of master state machine transition requests. Skipping states to change the slave state machine is not allowed.
E76	Slave received unknown state change request	Check the sequence of master state machine transition requests. Skipping states to change the slave state machine is not allowed.
E77	State machine error: Slave does not support boot mode	<ol style="list-style-type: none"> 1. Restart the PLC. 2. Contact the agent or Inovance.
E78	Firmware program invalid	<ol style="list-style-type: none"> 1. Restart the PLC. 2. Contact the agent or Inovance.
E79	Mailbox configuration error: Mailbox configuration error detected in slave boot state	<ol style="list-style-type: none"> 1. Restart the PLC. 2. Contact the agent or Inovance.
E7A	Mailbox configuration error: Mailbox configuration error detected in slave pre-operational state	<ol style="list-style-type: none"> 1. Restart the PLC. 2. Contact the agent or Inovance.
E7B	Sync manager error: Slave detected invalid sync manager configuration	<ol style="list-style-type: none"> 1. Restart the PLC. 2. Contact the agent or Inovance.
E7C	Input data invalid	Adjust the slave input PDO data configuration.
E7D	Output data invalid	Adjust the slave output PDO data configuration.
E7E	Synchronization error	<ol style="list-style-type: none"> 1. Restart the PLC. 2. Contact the agent or Inovance.
E7F	Sync manager watchdog timeout	<ol style="list-style-type: none"> 1. Restart the PLC. 2. Contact the agent or Inovance.
E80	Sync manager type invalid	<ol style="list-style-type: none"> 1. Restart the PLC. 2. Contact the agent or Inovance.

Fault Code ID	Description	Solution
E81	Output PDO configuration invalid	The slave does not support the configured number of output PDO object dictionary entries. Adjust the output PDO.
E82	Input PDO configuration invalid	The slave does not support the configured number of input PDO object dictionary entries. Adjust the input PDO.
E83	Watchdog configuration invalid	<ol style="list-style-type: none"> 1. Restart the PLC. 2. Contact the agent or Inovance.
E84	Slave requires cold start	<ol style="list-style-type: none"> 1. Restart the PLC. 2. Contact the agent or Inovance.
E85	Initialization state required	<ol style="list-style-type: none"> 1. Restart the PLC. 2. Contact the agent or Inovance.
E86	Pre-operational state required	<ol style="list-style-type: none"> 1. Restart the PLC. 2. Contact the agent or Inovance.
E87	Safe-operational state required	<ol style="list-style-type: none"> 1. Restart the PLC. 2. Contact the agent or Inovance.
E88	Input mapping invalid: Slave does not support the input PDO parameter configuration	<ol style="list-style-type: none"> 1. The input PDO part of the object dictionary does not match the slave firmware program. 2. The "check vendor ID" and "check product ID" options are disabled in the slave configuration, causing a mismatch between the slave configuration and the actual hardware.

Fault Code ID	Description	Solution
E89	Output mapping invalid: Slave does not support the output PDO parameter configuration	<ol style="list-style-type: none"> 1. The output PDO part of the object dictionary does not match the slave firmware program. 2. The "check vendor ID" and "check product ID" options are disabled in the slave configuration, causing a mismatch between the slave configuration and the actual hardware.
E8A	Slave configuration inconsistent	<ol style="list-style-type: none"> 1. Restart the PLC. 2. Contact the agent or Inovance.
E8B	Mode configuration error: Slave does not support free operation mode	<ol style="list-style-type: none"> 1. Restart the PLC. 2. Contact the agent or Inovance.
E8C	Mode configuration error: Slave does not support synchronous mode	<ol style="list-style-type: none"> 1. Restart the PLC. 2. Contact the agent or Inovance.
E8E	Parameter configuration error: Slave free operation mode requires three buffers	<ol style="list-style-type: none"> 1. Restart the PLC. 2. Contact the agent or Inovance.
E8F	Input and output invalid	<ol style="list-style-type: none"> 1. Restart the PLC. 2. Contact the agent or Inovance.
E90	DC synchronization error: Sync0 watchdog timeout in slave DC mode	<ol style="list-style-type: none"> 1. Restart the PLC. 2. Contact the agent or Inovance.
E91	DC synchronization error: No Sync0 interrupt signal detected during slave transition from safe-operational to operational state	<ol style="list-style-type: none"> 1. Restart the PLC. 2. Contact the agent or Inovance.
E92	DC synchronization error: Slave synchronization cycle time too small (Slave address: {Addr})	<ol style="list-style-type: none"> 1. Restart the PLC. 2. Contact the agent or Inovance.

Fault Code ID	Description	Solution
E94	DC synchronization configuration invalid	<ol style="list-style-type: none"> 1. Restart the PLC. 2. Contact the agent or Inovance.
E95	DC latch configuration invalid	<ol style="list-style-type: none"> 1. Restart the PLC. 2. Contact the agent or Inovance.
E96	PLL error: Slave lost synchronization with master	<ol style="list-style-type: none"> 1. Reconnect the slave to the network; the error may have been automatically reset. 2. The bus cycle is unreasonable. Recommended parameters: 125 μs to 8000 μs. The master synchronization offset value is unreasonable. Adjust the range (-50% to +50%).
E97	DC invalid	<ol style="list-style-type: none"> 1. Restart the PLC. 2. Contact the agent or Inovance.
E98	DC timeout	<ol style="list-style-type: none"> 1. Restart the PLC. 2. Contact the agent or Inovance.
E99	Synchronization cycle time error	<ol style="list-style-type: none"> 1. Restart the PLC. 2. Contact the agent or Inovance.
E9A	Sync0 configuration error: Slave Sync0 cycle time out of range	Adjust the DC synchronization cycle for Sync0.
E9B	Sync1 configuration error: Slave Sync1 cycle time out of range	Adjust the DC synchronization cycle for Sync1.
EA5	Slave MBX_AOE error	<ol style="list-style-type: none"> 1. Restart the PLC. 2. Contact the agent or Inovance.
EA6	Slave MBX_EOE error	<ol style="list-style-type: none"> 1. Restart the PLC. 2. Contact the agent or Inovance.
EA7	Slave MBX_COE error	<ol style="list-style-type: none"> 1. Restart the PLC. 2. Contact the agent or Inovance.

Fault Code ID	Description	Solution
EA8	Slave MBX_FOE error	1. Restart the PLC. 2. Contact the agent or Inovance.
EA9	Slave MBX_SOE error	1. Restart the PLC. 2. Contact the agent or Inovance.
EB3	Slave MBX_VOE error	1. Restart the PLC. 2. Contact the agent or Inovance.
EB4	Slave EEPROM address not accessible	Change the EEPROM access address or data length.
EB5	Slave EEPROM error	1. Restart the PLC. 2. Contact the agent or Inovance.
EB6	Slave external hardware not ready	1. Restart the PLC. 2. Contact the agent or Inovance.
EC4	Slave has restarted locally	1. Restart the PLC. 2. Contact the agent or Inovance.
ED4	Slave configuration error: Configuration of modules attached to the slave coupler does not match the actual hardware	Use the EtherCAT device scanning function to compare the scan results with the project configuration and identify the differences.

8.4 Appendix 4: Localbus Fault Codes

Localbus fault code IDs are independent of and do not conflict with other fault code IDs of the PLC. These IDs consist of three digits and are shown on the LED display in the following format.

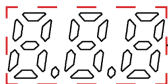

Fault code ID
For example, when the ID is "411", the LED display shows "411".

Fault Code ID	Meaning
411	Module offline
422	Module type mismatch
423	Module configuration failed

Fault Code ID	Meaning
424	Module status setting failed
425	No expansion module scanned
426	Module application parameter configuration error
431	Module power supply overvoltage
432	Module power supply undervoltage
433	Module power supply not connected
434	Module chip over-temperature
435	Module IC device failure
441	Channel disconnected
442	Channel short-circuited
443	Channel data over upper limit
444	Channel data below lower limit
445	Channel data overflow
446	Channel data underflow
447	Channel bus communication error

Service and Support

Should you encounter a safety accident during the use or operation of the product, or face challenges in operating and maintaining the equipment, which remain unresolved after the relevant documentation is consulted, we provide multiple channels to ensure prompt resolution:

- Channel #1: Contact service@inovance.com.
- Channel #2: Visit <https://www.inovance.com/global> to access document downloads, after-sales support, spare parts ordering, repair applications, and authenticity verification services.
- Channel #3: Download My Inovance app (<https://zshc-eu.inovance.com/download-pc/>) where you can access products info and documentation, and query product parameters.

We are committed to providing you with quick and professional technical support, and we look forward to your satisfaction and trust.